



MS3base/V3.57 Hardware Manual

Megasquirt-3 Product Range

MS3 1.5.x

Dated: 2018-07-06

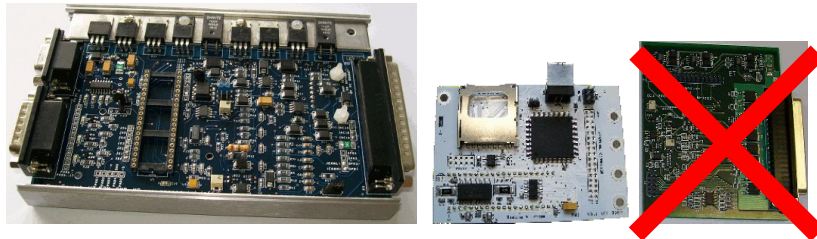

Hardware manual covering specific wiring and configuration of your Megasquirt MS3/V357 ECU.

This version of the documentation applies to:

- MS3 on a V3.57 mainboard without MS3X as shown above running firmware MS3 1.5.x
See the Setting Up manual for more detail on version numbers.

Does not apply to other Megasquirt products or other firmware versions.

Table of Chapters

1: Introduction.....	8
2: Megasquirt System Hardware.....	10
3: Wiring.....	12
4: Fuel System.....	61
5: Ignition System - fundamentals.....	71
6: Ignition system - specific operating modes.....	109
7: Throttles.....	178
8: Optional Hardware.....	179
9: Example wiring.....	179
10: Further information.....	181
11: Appendix A Schematics.....	181
12: Appendix B: junkyard guide to finding EDIS.....	193
13: Appendix C: V3.57 Board Setup / Jumpers.....	198
14: Revision history.....	204

Contents

- 1: Introduction.....8
 - 1.1 Emissions and disclaimer.....8
 - 1.2 Required tools.....8
 - 1.3 How to use this manual.....8
 - 1.4 Scope of advice without MS3X.....9
- 2: Megasquirt System Hardware.....10
 - 2.1 Overview.....10
 - 2.2 Megasquirt Installation.....10
 - 2.3 Wiring Harness.....11
 - 2.4 Crank / Cam Inputs.....11
 - 2.5 Sensor Inputs.....11
 - 2.6 Outputs.....11
 - 2.7 Tuning interface.....11
- 3: Wiring.....12
 - 3.1 Best Practices.....12
 - 3.1.1 Wire and connector choice.....12
 - 3.1.2 Soldering or crimping.....12
 - 3.1.3 Re-pinning the DB37.....12
 - 3.1.4 Fusing.....12
 - 3.1.5 4-pin relay pin-out note.....12
 - 3.1.6 Relay and accessory power routing.....12
 - 3.2 Grounding (Earthing) Schemes.....13
 - 3.2.1 Reasoning for sensor grounding.....13
 - 3.2.2 Reasoning for Megasquirt grounding.....14
 - 3.3 Core Wiring Diagram.....14
 - 3.3.1 Optional Connections.....15
 - 3.3.2 Additional internal inputs/outputs.....15
 - 3.3.3 Relay Board.....21
 - 3.4 Inputs.....23
 - 3.4.1 Crank and Cam Tach inputs.....23
 - 3.4.2 MAP (Manifold Absolute Pressure) sensor.....23
 - 3.4.3 IAT/MAT (Intake/Manifold Air Temperature) sensor.....24
 - 3.4.4 CLT (Coolant Temperature) sensor.....27
 - 3.4.5 TPS (Throttle Position Sensor).....28
 - 3.4.6 O2 (Oxygen) Sensor / Lambda Sensor.....28
 - 3.4.7 MAF (Mass Air Flow) Sensor.....30
 - 3.4.8 Flex / Switch input.....36
 - 3.4.9 Spare Analog (ADC) inputs.....37
 - 3.4.10 Switch inputs.....38
 - 3.4.11 B/LD boot jumper.....39
 - 3.4.12 CAN comms.....40
 - 3.4.13 Knock sensor.....41
 - 3.4.14 Speed sensor inputs.....42
 - 3.4.15 EGT input.....43

3.5	Outputs.....	44
3.5.1	Fuel Injector outputs.....	44
3.5.2	Ignition outputs.....	44
3.5.3	Fuel pump output.....	44
3.5.4	Idle valve.....	45
3.5.5	Tacho output.....	48
3.5.6	Other relay outputs.....	49
3.5.7	Boost control output.....	50
3.5.8	Alternator control wiring.....	50
3.6	Bench test wiring.....	59
3.6.1	Minimal connection.....	60
3.6.2	JimStim connection.....	60
4:	Fuel System.....	61
4.1	Introduction.....	61
4.1.1	Existing EFI Vehicle.....	62
4.1.2	Retro-fit EFI Vehicle.....	62
4.2	Single Fuel pump.....	62
4.3	Low pressure / high pressure - twin pump.....	62
4.4	Wiring the Fuel Pump.....	63
4.5	Fuel Line.....	63
4.6	Fuel filter.....	64
4.7	Fuel Pressure Regulator.....	64
4.8	Injector installation.....	65
4.9	Fuel Rails.....	65
4.10	Fuel Injectors.....	65
4.10.1	Injector Size.....	65
4.10.2	Injector Impedance and batch-fire wiring.....	67
4.10.3	Staged injection.....	70
4.10.4	Sequential injection.....	70
5:	Ignition System - fundamentals.....	71
5.1	Safety Notes.....	71
5.2	Crank and Cam tach inputs.....	71
5.2.1	Coil Negative Input.....	72
5.2.2	VR (magnetic) sensor input.....	73
5.2.3	Hall sensor input.....	75
5.2.4	Hall sensor input (built-in pull-up).....	78
5.2.5	Gear-tooth sensor input.....	80
5.2.6	GM LS 24X crank/cam sensors.....	80
5.2.7	GM LS 58X crank/cam sensors.....	81
5.2.8	Optical sensor.....	81
5.2.9	Distributor points input.....	82
5.2.10	Combined Ignition module (TFI, EDIS, HEI, GMDIS).....	82
5.2.11	Nissan CAS.....	83
5.2.12	4G63 / 6G72.....	84
5.2.13	Mitsubishi CAS with aftermarket disc.....	85
5.2.14	Adding a cam sensor input.....	85
5.3	Ignition outputs.....	87

5.3.1	Building ignition outputs.....	88
5.3.2	Logic coils.....	92
5.3.3	Amplifiers (ignitor, power transistor, ignition module).....	99
5.3.4	High current coils.....	103
5.3.5	CDI modules (e.g. MSD, Crane etc.).....	105
5.3.6	Mazda Rotary ignition wiring.....	106
5.3.7	Toyota DLI ignition wiring.....	107
6:	Ignition system - specific operating modes.....	109
6.1	Coil negative for fuel only.....	111
6.2	Distributor pickup.....	112
6.2.1	Traditional vac/mech distributor.....	112
6.2.2	Rotor / Output phasing - all distributor installs.....	115
6.2.3	Distributor with hall/optical 'trigger return'.....	116
6.2.4	Distributor with basic crank trigger.....	118
6.2.5	Distributor with crank trigger wheel.....	118
6.3	Ford TFI.....	118
6.4	GM HEI7.....	120
6.5	GM HEI8.....	121
6.6	Dual Sync Distributor.....	122
6.7	Ford EDIS.....	123
6.7.1	System components.....	123
6.7.2	ECU wiring.....	124
6.7.3	Module wiring.....	125
6.7.4	36-1 trigger wheel and VR sensor.....	126
6.7.5	Checking the timing.....	130
6.8	GM DIS (for reference only).....	130
6.9	Toothed Wheel.....	131
6.9.1	Wheel combinations.....	131
6.9.2	Terminology notes.....	133
6.9.3	Wheel naming.....	133
6.9.4	Retrofit install.....	134
6.9.5	Existing install.....	135
6.9.6	Missing tooth crank wheel.....	135
6.9.7	Missing tooth cam wheel.....	137
6.9.8	Missing tooth crank wheel and single tooth cam wheel.....	137
6.9.9	Missing tooth crank wheel and polled cam wheel.....	140
6.9.10	Nippondenso CAS.....	144
6.9.11	Non-missing tooth crank wheel with one cam tooth.....	149
6.9.12	Mitsubishi CAS with aftermarket disc - single coil / wasted spark.....	152
6.9.13	Mitsubishi CAS with aftermarket disc - coil-on-plug.....	153
6.9.14	Other wheel arrangements.....	154
6.9.15	Example: Ford Zetec.....	154
6.10	Neon/420A.....	155
6.11	36-2+2 (NGC).....	157
6.12	36-2-2-2.....	158
6.13	Miata 99-05.....	158
6.14	Subaru 6/7.....	159

6.15	6G72.....	159
6.16	IAW Weber.....	160
6.17	Mitsubishi CAS 4/1.....	161
6.18	Mitsubishi 4G63 (and Miata).....	161
6.19	Twin trigger.....	164
6.20	Chrysler 2.2/2.5.....	164
6.21	Renix 44-2-2 (66-2-2-2).....	165
6.22	Suzuki Swift.....	165
6.23	Suzuki Vitara 2.0.....	165
6.24	Daihatsu 3cyl.....	165
6.25	Daihatsu 4cyl.....	166
6.26	VTR1000.....	166
6.27	Rover#1.....	166
6.28	Rover#2.....	167
6.29	Rover#3.....	167
6.30	GM7X.....	167
6.31	QR25DE.....	168
6.32	Honda RC51.....	168
6.33	GM LS1 (24X).....	168
6.34	GM LS2 (58X).....	170
6.35	YZF1000.....	170
6.36	HD 32-2.....	171
6.37	Miata 36-2.....	171
6.38	Fiat 1.8 16V.....	171
6.39	GM Optispark.....	172
6.40	Nissan SR20.....	173
6.41	Nissan RB25.....	173
6.42	Honda Acura V6.....	173
6.43	VQ35DE.....	173
6.44	Jeep 2000.....	174
6.45	Jeep 2002.....	174
6.46	Zetec VCT.....	174
6.47	Flywheel tri-tach.....	175
6.48	2JZ VVTi.....	175
6.49	Honda TSX/D17.....	176
6.50	Mazda6 2.3 VVT.....	176
6.51	Viper V10 (gen 2).....	176
6.52	Viper V10 (gen 1).....	177
6.53	Honda K24A2.....	177
7:	Throttles.....	178
8:	Optional Hardware.....	179
8.1	Expansion boards.....	179
9:	Example wiring.....	179
9.1	Nitrous.....	179
9.2	Component pinouts.....	181
10:	Further information.....	181
11:	Appendix A Schematics.....	181

- 12: Appendix B: junkyard guide to finding EDIS.....193
 - 12.1 North America - EDIS4.....193
 - 12.2 Europe - EDIS4.....194
 - 12.3 Europe - EDIS6.....196
 - 12.4 Europe - EDIS8.....196
 - 12.5 Europe - 36-1 trigger disc.....196
 - 12.6 Europe - VR sensor.....197
 - 12.7 World - Coilpack(s).....197
- 13: Appendix C: V3.57 Board Setup / Jumpers.....198
 - 13.1 Introduction.....198
 - 13.2 Build choices.....198
 - 13.3 Power transistor mounting.....198
 - 13.4 Jumper Wires.....199
 - 13.5 Voltage Testing.....200
 - 13.6 MS3 CPU Card Mounting.....200
 - 13.7 Case Fitment.....201
 - 13.8 Custom circuits.....203
- 14: Revision history.....204

1: Introduction

The MS3X/V3.57 is an ECU based on Megasquirt-3 technology, consisting internally of an MS3 card and an MS3X expansion card installed on a surface mount V3.57 mainboard. This manual covers MS3X/V3.57 specific installation details and should be used in conjunction with the general Megasquirt-3 Setting up and Megasquirt-3 TunerStudio reference manuals.

1.1 Emissions and disclaimer

All parts are sold for OFF ROAD RACE-ONLY ground-vehicle use only, or vehicles that pre-date any federal and state emissions control requirements. Aftermarket EFI/EMS systems are not for sale or use on pollution controlled vehicles. Alteration of emission related components constitutes tampering under the US EPA guidelines and can lead to substantial fines and penalties. Your country/state/district may also have specific rules restricting your tampering with your vehicle's emissions system.

Race parts are inherently dangerous and may cause injury or damage if improperly modified or altered before use. The publishers of this manual will not be held liable for and will not pay you for any injuries or damage caused by misuse, modification, redesign, or alternation of any of our products. The publishers of this manual will not be held in any way responsible for any incidental or consequential damages including direct or indirect labor, towing, lodging, garage, repair, medical, or legal expense in any way attributable to the use of any item in our catalog or to the delay or inconvenience caused by the necessity of replacing or repairing any such item.

1.2 Required tools

Tuning laptop
Stroboscopic timing light
Multi-meter (volts, ohms)
Screwdrivers
Wire cutters
Terminal crimpers
Soldering iron and solder
Heat-shrink tubing
Fire extinguisher

Although not essential, the following are highly recommended:

Oscilloscope or scope-meter or soundcard scope
Test light
Power probe

1.3 How to use this manual

Customers new to EFI are advised to read all of sections 1-5 as these cover some fundamental concepts and give an overview of how to connect up the various EFI components.

More experienced customers can likely skim through sections 1-5.

Section 3.3 is the external wiring diagram, you should print that out.

Section 6 covers the many different tach trigger input schemes (wheel decoders) that exist to support numerous OEM trigger wheel patterns. Find the section that is appropriate for your engine and read that one.

This guide includes a number of notes which are indicated as follows:



This symbol indicates an “Information” note.



This symbol indicates a “Caution” note.



This symbol indicates a “Warning” note.

Installing or tuning your Megasquirt incorrectly can potentially cause damage to your engine, the Megasquirt or external hardware. Warning notes indicate specific areas where you need to exercise extreme care.

Do not rely on these warnings as your only criteria for taking care !

For additional help and support, visit the website www.msextra.com

1.4 Scope of advice without MS3X

This manual is written for the MS3/V3.57 without the MS3X board. Instructions for DIY modifications for inputs and outputs are given using the mainboard connections only – not the “MS3X” pin headers on the MS3 card.

Customers requiring additional inputs and outputs with less internal DIY modifications are recommended to consider upgrading with the MS3X card.



The MS3X card is an input/output board for the MS3 and features:

- 8 hi-z injector drivers (or low-z with external resistors)
- 8 logic level spark outputs
- 6 mid current outputs for driving small solenoids or relays (on/off or PWM)
- 3 analogue inputs (0-5V)
- 4 switch inputs
- flex-fuel sensor input
- Cam sensor input

This manual does not cover usage of the MS3X !

See the MS3X/V3.57 hardware manual for V3.57 + MS3 + MS3X

2: Megasquirt System Hardware

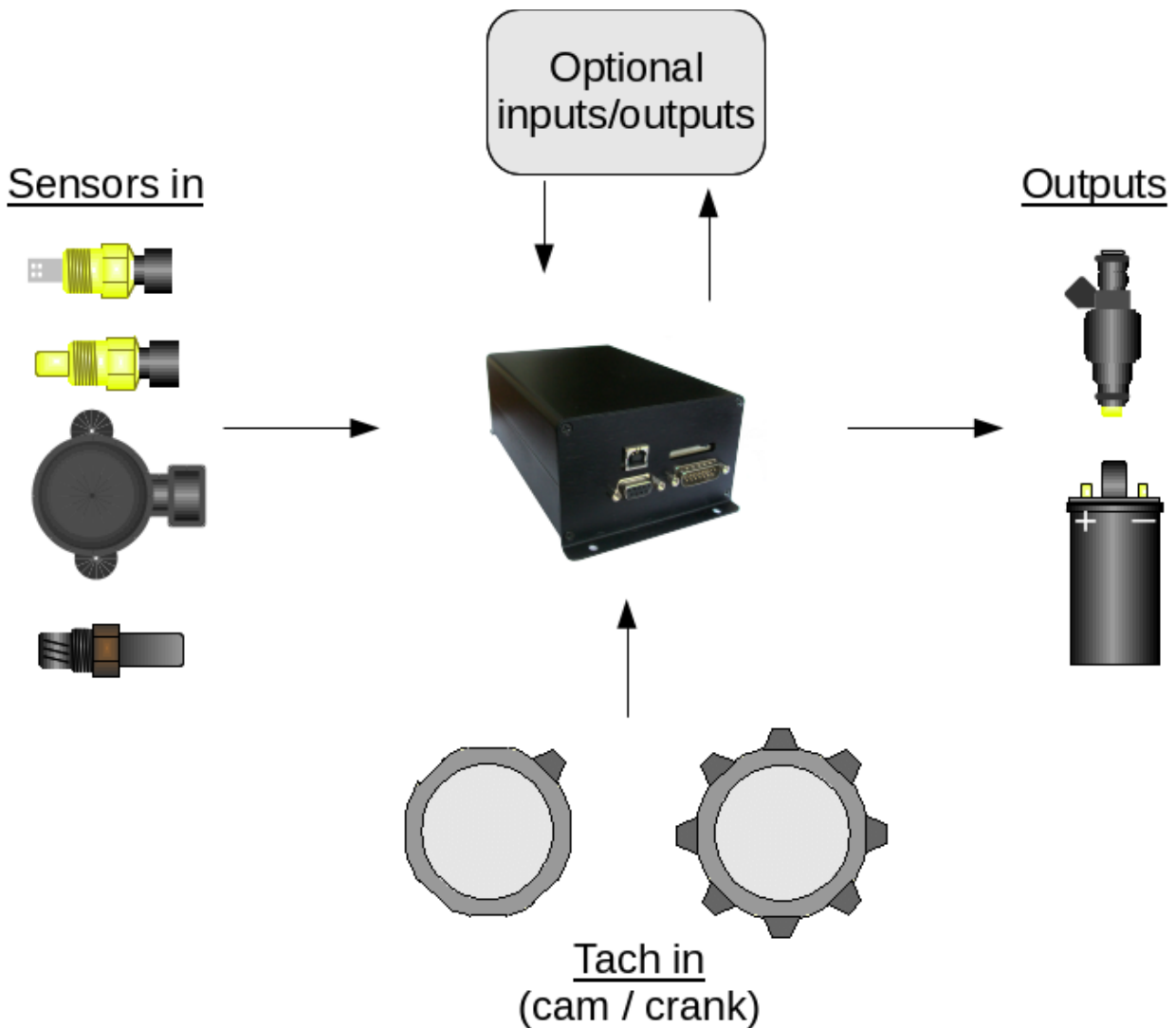

2.1 Overview

The Megasquirt engine control unit (ECU) receives signals from the various input sensors and then controls the fuel and spark outputs to run the engine.

For engines that already have fuel injection installed, you will likely be able to re-use many of the existing sensors and output hardware.

For engines that do not have existing fuel injection, review the available options in this manual and select the most suitable components to complete your install.

2.2 Megasquirt Installation

The Megasquirt is not designed to be installed in the engine compartment. Typically it will be installed under the dash in a car or under the seat on a bike - but away from direct engine temperatures. The temperature must not exceed 185°F (85°C.) It should be protected from water.

2.3 Wiring Harness

The Megasquirt can be supplied with a "pigtail" wiring harness to form the basis of your own wiring.

2.4 Crank / Cam Inputs

The Crank and Cam sensors provide the Megasquirt with engine position information which is critical for ignition timing. Fuel-only installs will often take a signal from an existing inductive ignition coil.

2.5 Sensor Inputs

The sensor inputs provide the ECU with information about current engine operating conditions and are used to calculate the fuel and spark outputs.

The primary inputs are MAP sensor, MAT sensor, CLT sensor, TPS and O2 input.

2.6 Outputs

Based on the crank/cam and sensor inputs the Megasquirt calculates the required fuel and spark outputs.

2.7 Tuning interface

The Megasquirt uses either:

a) an RS232 interface for tuning. This is provided as a standard DB9 serial connector. Your computer will likely require a USB-serial adapter also - adapter cables based on the FTDI chipset are recommended. Some customers have reported unreliability with Prolific based cables.

b) a built in USB-serial interface for tuning. This is based on the FT232 chipset from FTDI.

Do not connect both interfaces at the same time.

Megasquirt also has CAN communications for connection to add-on modules or dashes.

3: Wiring

A main step in your Megasquirt installation is connecting up the wiring. Be sure to follow the guidance here to avoid common mistakes that will often lead to problems.

3.1 Best Practices

3.1.1 Wire and connector choice

For many first-time users, it may be tempting to re-use old connectors and wiring. While this may sometimes be cost-effective, beware of false economy. Using fresh connectors and suitable automotive grade wiring can save many a headache. Be particularly aware of using wire or components that are not temperature rated high enough, engines get HOT and the insulation on sub-standard wires can melt or degrade leading to erratic connections or short circuits. All components must be rated for 105°C / 220°F as a minimum.

There are many suppliers dedicated to supplying the required items to construct wiring harnesses.

3.1.2 Soldering or crimping

This is mainly down to personal choice, some installers prefer a soldered joint, others swear that crimped connections are superior. The key task is to make a reliable connection.

In your wiring harness you will need to ensure that all joints are effective both electrically and mechanically. Always test by tugging on the wires to ensure that they are not loose. Use heat-shrink tubing over connections to insulate them and prevent shorts.

Don't even think about using scotch blocks - they are bad enough for installing a radio or trailer plug!

3.1.3 Re-pinning the DB37

Optionally, to create the smallest wiring harness possible, the DB37 connector in a pre-made loom can have any unused spare wires removed.

3.1.4 Fusing

It is required that the system be fused - as shown in the general wiring diagram. Remember that an automotive battery is capable of supplying hundreds of amps into a short circuit which can easily melt wires or start a fire. Appropriate fuses can help reduce this risk and save component damage.

If there is a risk of the connections becoming damp then it can be worth applying petroleum jelly (e.g. Vaseline) to the connections to slow the corrosion.

3.1.5 4-pin relay pin-out note

Be aware that there are two incompatible "standards" for four-pin automotive relays. Mixing them up will usually cause a short-circuit in your wiring harness. The type where pin 85 is opposite 86 is preferred as this is the same as 5-pin relays.

3.1.6 Relay and accessory power routing

Any relays, solenoids or lamps operated by the Megasquirt must only be powered when the Megasquirt is on. Typically it is easiest to take their power from the "fuel pump relay" so they are only powered when the engine is running. Miswiring accessories can cause power to backfeed into the Megasquirt causing unexpected behavior such as running-on.

3.2 Grounding (Earthing) Schemes



Implementing a correct grounding scheme is critical to a successful Megasquirt install.

Connecting sensors to the wrong ground, using corroded ground points or dubious original wiring are sure-fire ways to give you a headache.

There are three key rules:

1. All sensors must ground at the Megasquirt
2. Ground the Megasquirt at the battery negative or engine block/head using all available ground wires.
3. Ground ignition modules or wideband controllers to the same ground.

3.2.1 Reasoning for sensor grounding

When a current flows through a wire there is always a voltage drop, the bigger the current, the bigger the drop (this is ohm's law.) During cranking there is a very large current flowing through the ground strap from battery to engine and perhaps a few volts may be dropped across it. Even during running, a number of amps will flow through the Megasquirt grounds to the engine.

The sensors (coolant, air temp, throttle position, wideband, tach input) all use low current, low voltage signals. The Megasquirt measures the voltage from the sensor and converts it into a temperature, position etc. reading. If that sensor is grounded to anything other than the Megasquirt itself, then that input voltage will be altered by any external voltage drops. For a sensitive measurement such as AFR (lambda) this can be a real problem. All good wideband controllers offer a high-current ground (connects to engine) and a sensor/signal ground (connects to Megasquirt.)

Tach input (e.g. crank, cam sensors) will be even worse - they can show false or missed teeth and cause sync-loss due to the ground voltage difference.

The following two diagrams illustrate good and bad wiring schemes showing where the troublesome voltage drops are created and how that would cause sensor readings to be garbage.

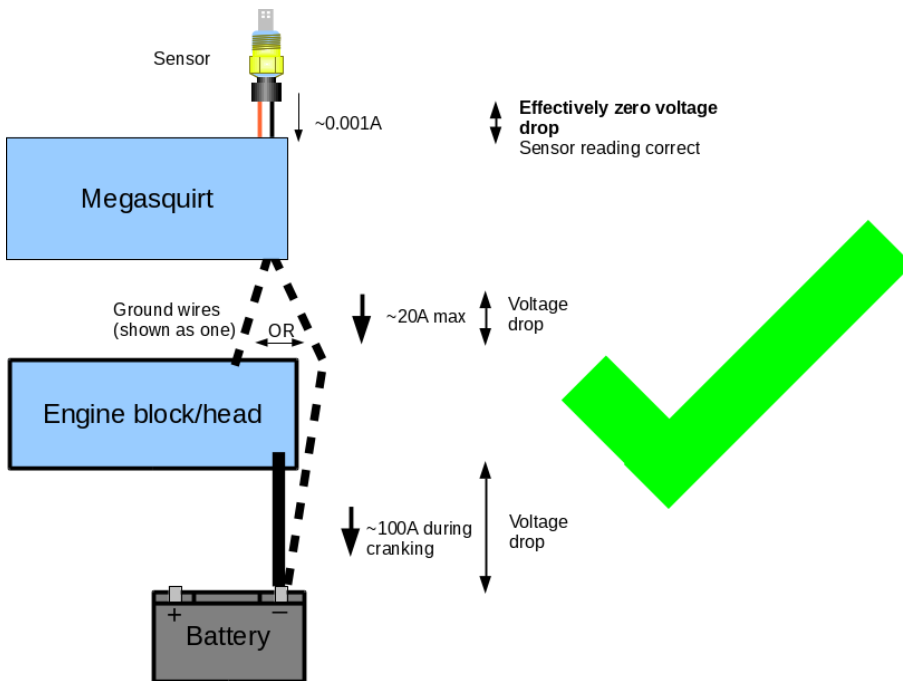

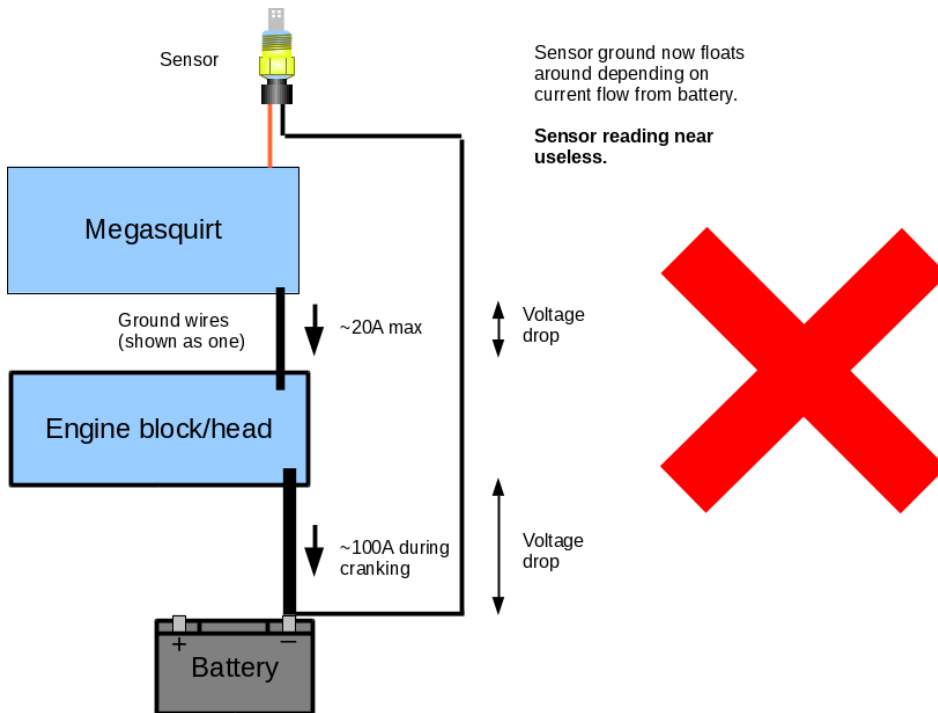

If re-using or splicing into OEM wiring, do not assume that their wiring is OK. Always follow the above principles.

As a check, with the Megasquirt connector unplugged, ensure that the sensor grounds have no continuity to engine/body ground. Your sensor readings will be junk if they do have continuity - the sensors must ground at the Megasquirt **only**.

3.2.2 Reasoning for Megasquirt grounding

The current recommendation is to ground all ground wires to the battery negative terminal as the battery acts like a large smoothing capacitor.

It is less preferred, but still successful in most cases, to ground the ECU to the engine block or cylinder head. Avoid grounding the ECU to the frame rails or sheet metal as these points often have issues with rust and spot welds limiting how much current can flow through them.

Installs using Ford TFI or GM HEI7/8 must ground the ECU to the engine as these ignition systems are grounded through the distributor, using a different ground could easily cause a problem.

Most importantly, ground the ECU and all power devices to the same place (i.e. battery or block.) This is especially true with wideband oxygen sensor controllers that do not have an analogue ground (e.g. Innovate LC1.)

3.3 Core Wiring Diagram

Refer to the diagrams on the following pages.

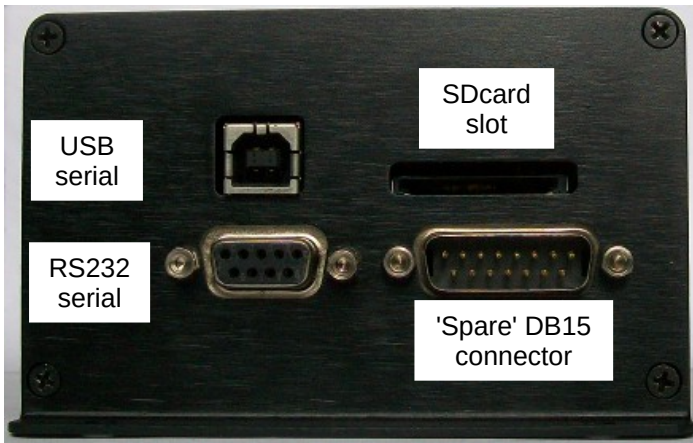
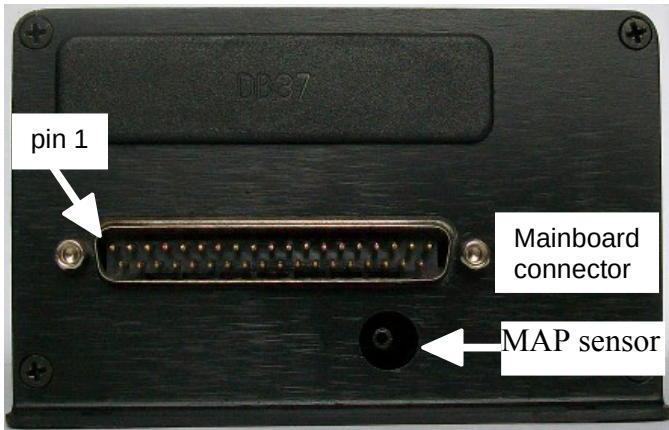

3.3.1 Optional Connections

The following wiring diagram and table show a number of functions in braces (). These indicate optional connections. These must be connected internally by you (or the ECU builder) and may be different depending on builder. Double check how you assembled it or ask your builder.

SPR1, SPR2 are typically used as CANH, CANL (JS6, JS8)

SPR3, SPR4 have no standard function and are spare

IAC1A, IAC1B, IAC2A, IAC2B are typically connected to the stepper outputs from the MS3 card.

FIDLE as standard is only suitable for switching a relay. To use it with a 2-wire PWM idle valve the transistor on the mainboard needs upgrading. This is covered later.

IGN is typically connected internally to a high-current ignition driver (BIP373)

Installs with MS3X will typically use the MS3X outputs for sequential logic spark, sequential fuel and idle valve.

All of the GND pins are connected internally, the wiring here is recommended.

Extra high current fuel pumps may benefit from their own relay for minimal voltage drop.

3.3.2 Additional internal inputs/outputs

The following pin connections are available within the ECU, instructions on using them are contained within the MS3base/V3.57 Hardware manual.

Pin/pad	CPU port	In/Out	Function	Max amps
---------	----------	--------	----------	----------

JS0*	PJ0 +PJ6	Out	IAC1A, 0-12V switched pair with IAC1B	0.5A
JS1*	PJ0 + PJ6	Out	IAC1B, 0-12V switched pair with IAC1A	0.5A
JS2*	PJ1 + PJ6	Out	IAC2A, 0-12V switched pair with IACAB	0.5A
JS3*	PJ1 + PJ6	Out	IAC2B, 0-12V switched pair with IAC2A	0.5A
JS4#	AD7	In	Spare 0-5V analog input	-
JS5#	AD6	In	Spare 0-5V analog input	-
JS7#	PE0	In	Spare ground-switch input	-
JS10#	PT5	In/Out	Optional cam input or general input/output.	0.02A
JS11#	PJ7	In/Out	General input/output.	0.02A
D14	PM3	Out	LED negative can be used for relay output.	0.2A
D15	PM5	Out	LED negative can be used for relay output.	0.2A
D16	PM4	Out	LED negative can be used for relay output.	0.2A

Pins marked * operate in pairs. When JS0 is 12V, JS1 is 0V. JS0-3 are typically wired to IAC1A,1B,2A,2B and can be directly connected to a stepper idle motor.

All pins marked # in this table are raw CPU pins and must not be directly connected to anything outside of the Megasquirt case without a protective circuit.

Megasquirt-3 V3.0/V3.57 wiring

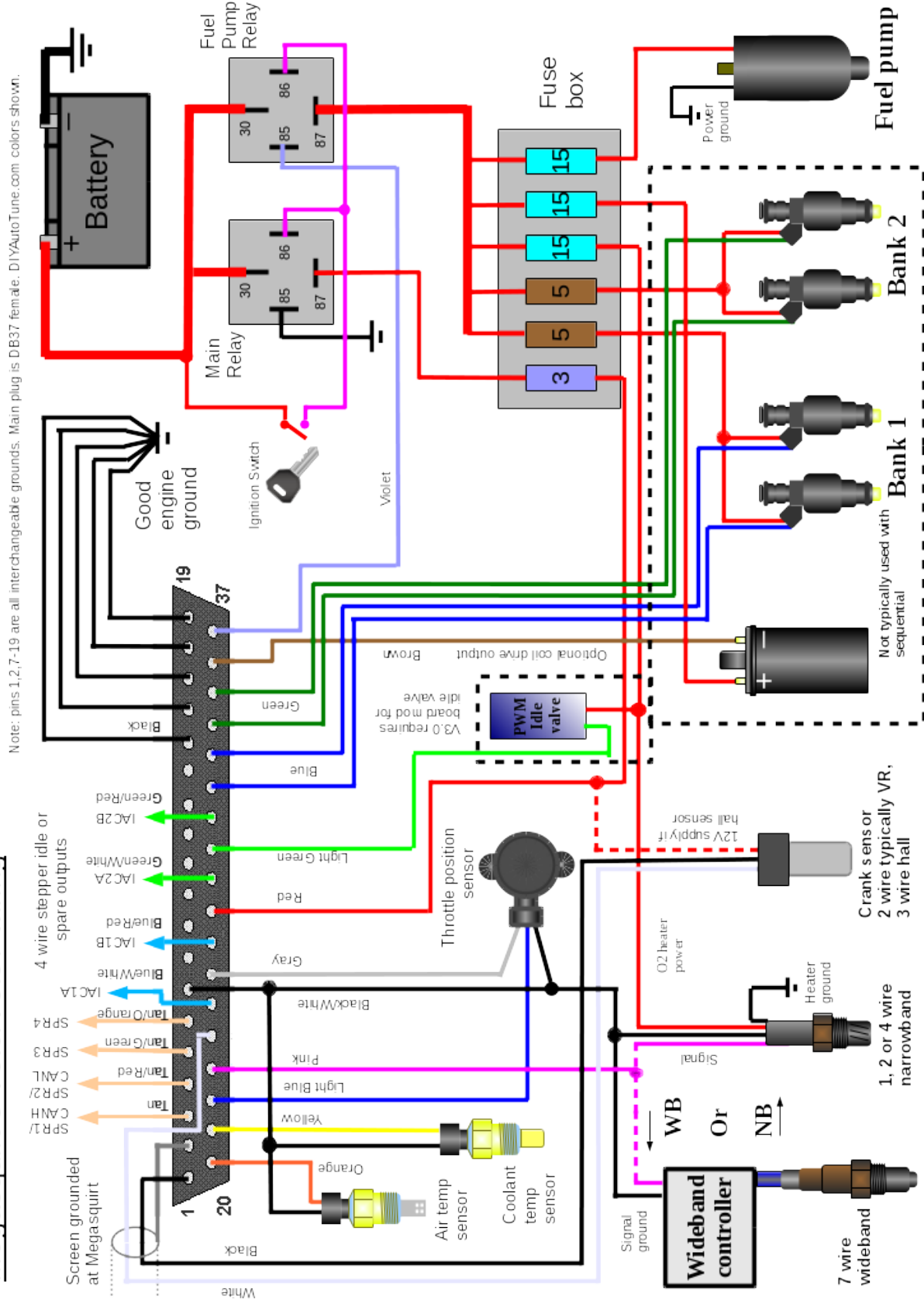

Main plug (DIYAutoTune.com colors)

Pin#	Name	Color	In/Out	Function	Max amps
1	GND	Black	GND	Crank sensor ground	-
2	GND	-	GND	Crank sensor shield	-
3	SPR1	Tan	(Comms)	(CAN communications)	-
4	SPR2	Tan/Red	(Comms)	(CAN communications)	-
5	SPR3	Tan/Green	-	spare	-
6	SPR4	Tan/Orange	-	spare	-
7	GND	Black/White	GND	Sensor ground	-
8	GND	-	GND	spare GND	-
9	GND	-	GND	spare GND	-
10	GND	-	GND	spare GND	-
11	GND	-	GND	spare GND	-
12	GND	-	GND	spare GND	-
13	GND	-	GND	spare GND	-
14	GND	-	GND	spare GND	-
15	GND	Black	GND	POWER GROUND	-
16	GND	Black	GND	POWER GROUND	-
17	GND	Black	GND	POWER GROUND	-
18	GND	Black	GND	POWER GROUND	-
19	GND	Black	GND	POWER GROUND	-
20	MAT	Orange	In	MAT sensor input	-
21	CLT	Yellow	In	CLT sensor input	-
22	TPS	Light Blue	In	TP Sensor input	-
23	O2	Pink	In	Oxygen/lambda sensor in	-
24	TACH IN	White in shielded wire	In	'Crank' Tach input	-
25	IAC1A	Blue/White	(Out)	(IAC1A)	0.5A
26	TPSVREF 5V	Gray	Out	5V supply for TPS	0.1A
27	IAC1B	Blue/Red	(Out)	(IAC1B)	0.5A
28	+12V In	Red	In	Main power feed	< 1A
29	IAC2A	Green/White	(Out)	(IAC2A)	0.5A
30	FIDLE	Light Green	Out	Idle valve output	0.1A *
31	IAC2B	Green/Red	(Out)	(IAC2B)	0.5A
32	INJ1	Blue	Out	Injector bank 1 output	7A
33	INJ1	Blue	Out	Injector bank 1 output	7A
34	INJ2	Green	Out	Injector bank 2 output	7A
35	INJ2	Green	Out	Injector bank 2 output	7A
36	IGN	Brown	(Out)	(High current ignition)	7A
37	FP (Pump)	Violet	Out	Fuel pump relay output	0.1A

MS3X wiring

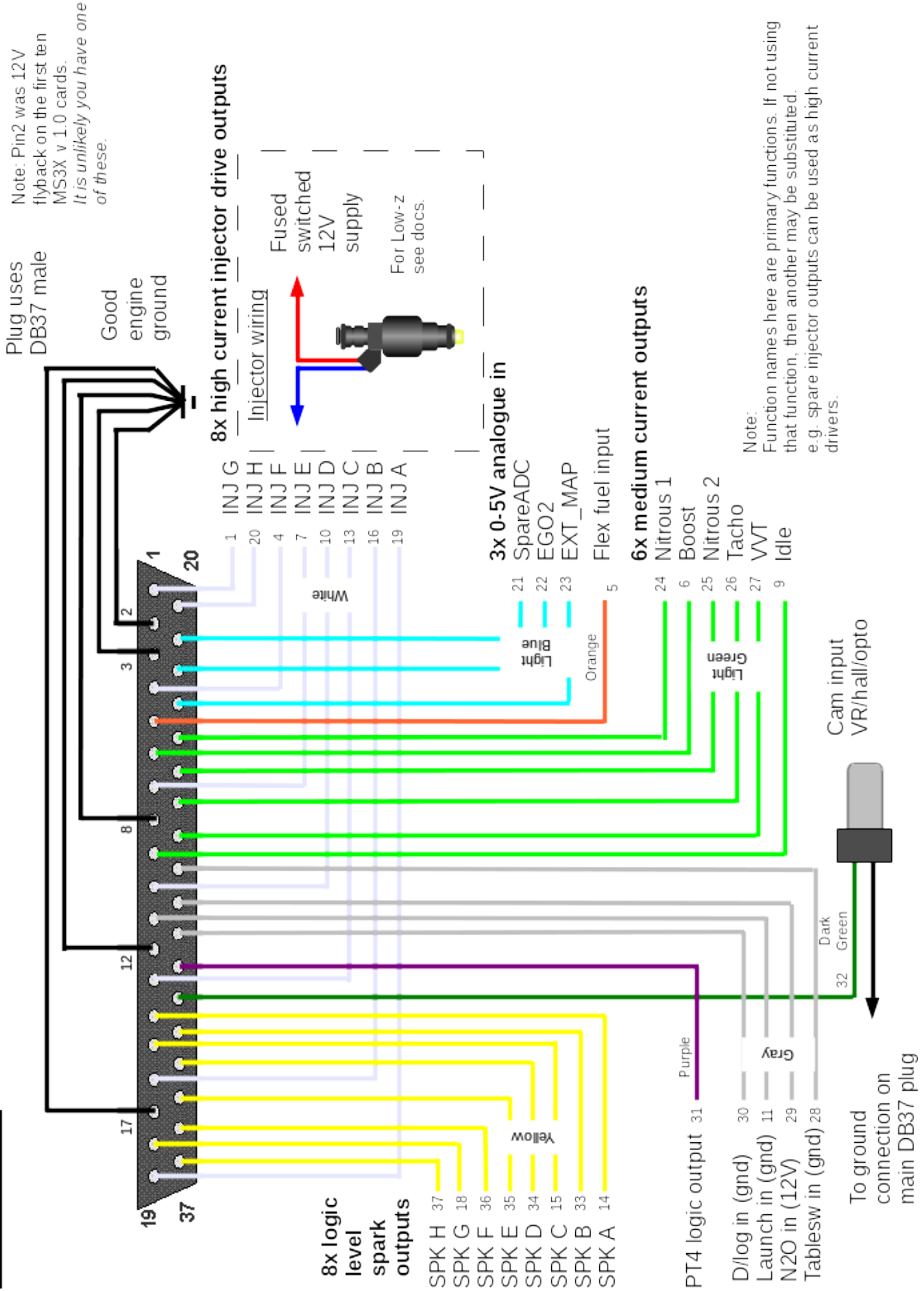

Note:
Function names here are primary functions. If not using that function, then another may be substituted.
e.g. spare injector outputs can be used as high current drivers.

MS3X plug (DIYAutoTune.com colors)

Pin#	Name	Color/Stripe	In/Out	Function	Max amps
1	Inj G	White/Dark Blue	Out	Injector G output	5A
2	GND	Black	GND	POWER GROUND	-
3	GND	Black	GND	POWER GROUND	-
4	Inj F	White/Dark Green	Out	Injector F output	5A
5	Flex	Orange	In	Flex fuel	-
6	Boost	Light Green/Red	Out	Mid-current output	3A
7	Inj E	White/Red	Out	Injector E output	5A
8	GND	Black	GND	POWER GROUND	-
9	Idle	Light Green/Pink	Out	Mid-current output	3A
10	Inj D	White/Pink	Out	Injector D output	5A
11	Launch in	Gray/Red	In	Ground-switch input	-
12	GND	Black	GND	POWER GROUND	-
13	Inj C	White/Light Green	Out	Injector C output	5A
14	Spark A	Yellow	Out	0-5V logic spark A output	0.03A
15	Spark C	Yellow/Light Green	Out	0-5V logic spark C output	0.03A
16	Inj B	White/Orange	Out	Injector B output	5A
17	GND	Black	GND	POWER GROUND	-
18	Spark G	Yellow/Dark Blue	Out	0-5V logic spark output	0.03A
19	Inj A	White	Out	Injector A output	5A
20	Inj H	White/Purple	Out	Injector H output	5A
21	SpareADC	Light Blue	In	0-5V analog input	-
22	EGO2	Light Blue/Dark Blue	In	0-5V analog input	-
23	EXT_MAP	Light Blue/Red	In	0-5V analog input	-
24	Nitrous 1	Light Green	Out	Mid-current output	3A
25	Nitrous 2	Light Green/Dark Blue	Out	Mid-current output	3A
26	Tacho	Light Green/Orange	Out	Mid-current output	3A
27	VVT	Light Green/Dark Green	Out	Mid-current output	3A
28	Tables witch in	Gray/Purple	In	Ground-switch input	-
29	Nitrous in	Gray/Dark Blue	In	+12V switch input	-
30	Datalog in	Gray	In	Ground-switch input	-
31	PT4	Purple	In/Out	0/5V input or output	0.02A
32	Cam input	Dark Green	In	'Cam' Tach input	-
33	Spark B	Yellow/Orange	Out	0-5V logic spark B output	0.03A
34	Spark D	Yellow/Pink	Out	0-5V logic spark D output	0.03A
35	Spark E	Yellow/Red	Out	0-5V logic spark E output	0.03A
36	Spark F	Yellow/Dark Green	Out	0-5V logic spark F output	0.03A
37	Spark H	Yellow/Purple	Out	0-5V logic spark H output	0.03A

3.3.3 Relay Board

The 'Relay Board' is an optional add-on that may be useful for installs that do not have any existing EFI wiring. It provides a 'main' relay to switch clean power to the Megasquirt, a 'fuel pump' relay to operate the pump and accessories and a 'fast idle' relay for an on/off type idle valve.

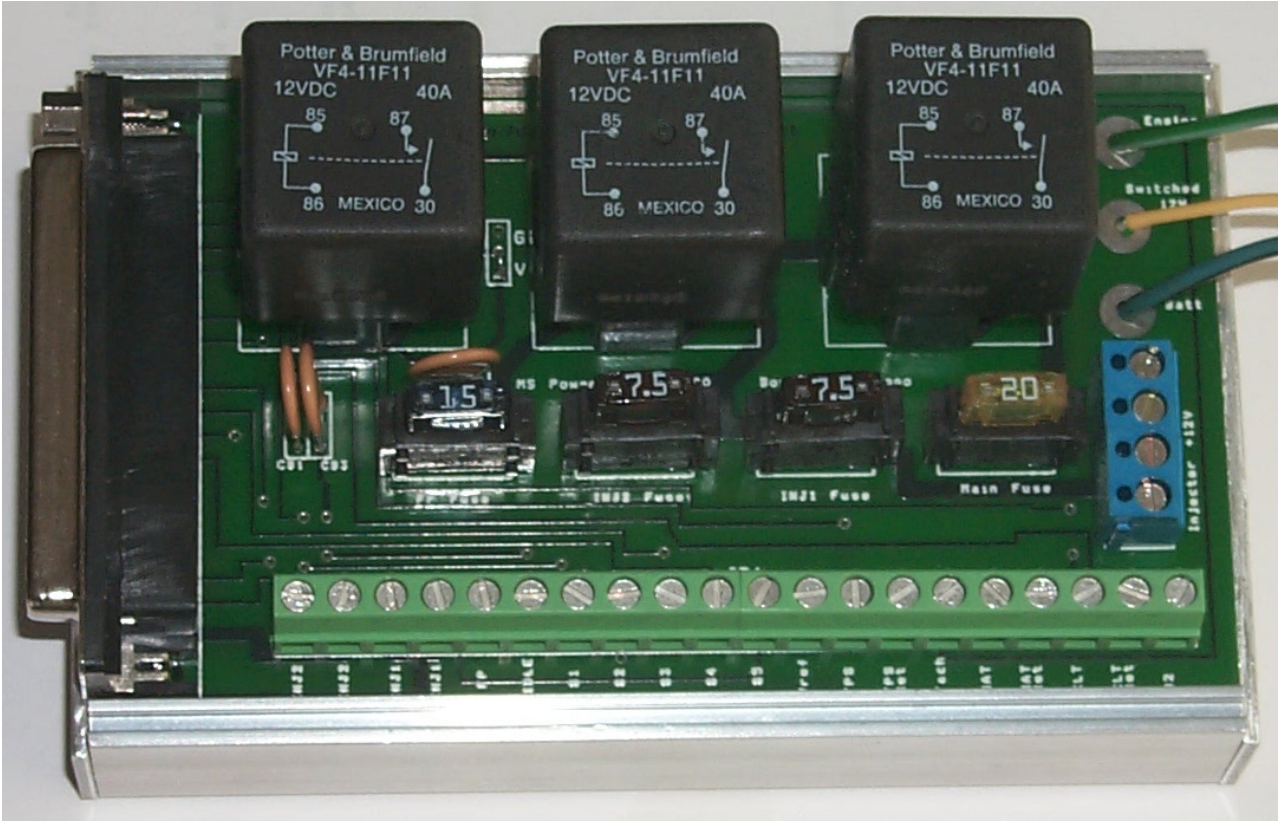

Not recommended for:

- sequential installs
- race installs
- low impedance injectors
- installs where the screw terminals connections may get wet.

For all installs, the MS3X plug for sequential fuel and injection requires its own harness.

Main plug to Relay board cross reference

DB37 #	DB37 Name	Relay Board #	Relay Board Name	In/Out	Function	Max amps
1-2	GND	-	Engine GND	GND	POWER GROUND	-
3	SPR1	N/A	Not available*	(Comms)	(CAN communications)	-
4	SPR2	N/A	Not available*	(Comms)	(CAN communications)	-
5	SPR3	N/A	Not available*	-	spare	-
6	SPR4	N/A	Not available*	-	spare	-
7-18	GND	-	Engine GND	GND	POWER GROUND	-

19	GND	14	TPS Ret	GND	Sensor GND	-
19	GND	17	MAT Ret	GND	Sensor GND	
19	GND	19	CLT Ret	GND	Sensor GND	
20	MAT	16	Air Temp	In	MAT sensor input	-
21	CLT	18	Coolant	In	CLT sensor input	-
22	TPS	13	TPS	In	TP Sensor input	-
23	O2	20	O2	In	Oxygen/lambda sensor in	-
24	TACH IN	15	Tach/Ignition	In	'Crank' Tach input	-
25	IAC1A	7	S1	(Out)	(IAC1A)	0.5A
26	TPSVREF 5V	12	VREF	Out	5V supply for TPS	0.1A
27	IAC1B	8	S2	(Out)	(IAC1B)	0.5A
28	+12V In	-	-	In	From main relay	
29	IAC2A	9	S3	(Out)	(IAC2A)	0.5A
30	FIDLE	(6)	-	Out	Via idle relay	
31	IAC2B	10	S4	(Out)	(IAC2B)	0.5A
32	INJ1	3 + 4	INJ1	Out	Injector bank 1 output	7A
33	INJ1	3 + 4	INJ1	Out	Injector bank 1 output	7A
34	INJ2	1 + 2	INJ2	Out	Injector bank 2 output	7A
35	INJ2	1 + 2	INJ2	Out	Injector bank 2 output	7A
36	IGN	11	S5	(Out)	(High current ignition)	7A
37	FP (Pump)	(5)	-	Out	Via fuel pump relay	

Relay Outputs

The FIDLE and FP ground outputs from the Megasquirt are used to control relays on the relay board.

Relay Board #	Relay Board Name	In/Out	Function	Max amps
6	FIDLE	RELAY OUT	On/off idle valve	3A
5	FP	RELAY OUT	Fuel pump relay	15A

Notes:

1. SPR1,2,3,4 connections from the mainboard are not available on the relay board. You will need to cut into the relay board cable and break these connections out.
2. INJ1, 2 power feeds have 7.5A fuses. These are intended for batchfire injectors only.
3. The 'FIDLE' output is hardwired to a relay. This is jumper selectable using to provide a 12V ("V") output or a ground ("G") output. Do not used for very high current devices. This could be used to operate a secondary fan relay.

4. When using a PWM idle valve from the 'FIDLE' output, the idle relay must be left out and bypassed.

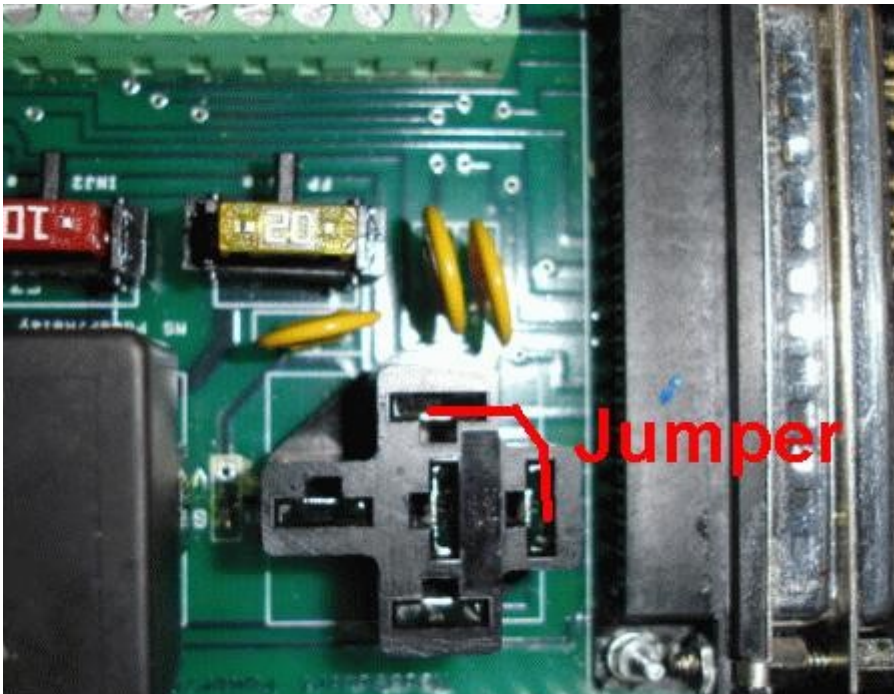

3.4 Inputs

3.4.1 Crank and Cam Tach inputs



These sensors provide the Megasquirt with engine position information and are used to schedule fuel and spark. See Crank and Cam tach inputs for detailed information on these sensors and wiring.

3.4.2 MAP (Manifold Absolute Pressure) sensor

The MS3/V3.0 uses an internal MAP sensor.

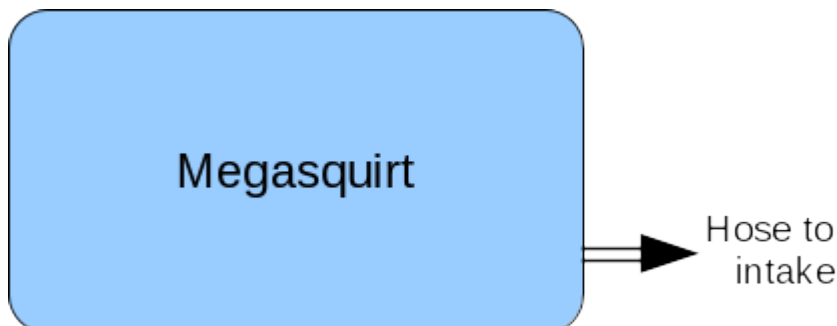

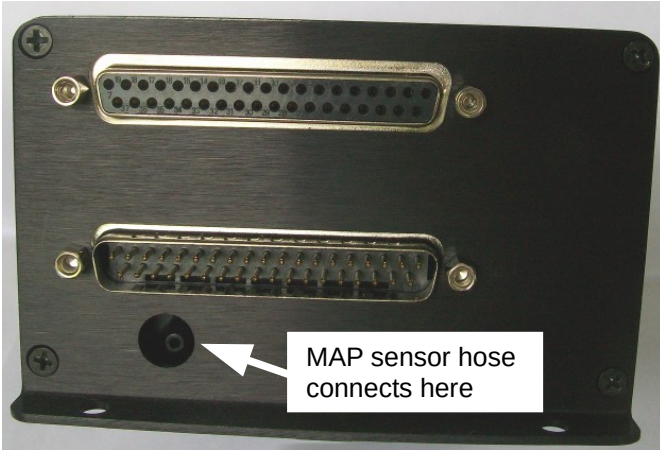

(MAP sensor is centred on MS3X/V3.57)

This sensor measures air pressure on absolute scale where zero is a complete vacuum and sea-level ambient pressure is around 101kPa. This sensor is the primary input for the "Speed-Density" fuel algorithm. Alpha-N users do not require a MAP sensor and can optionally use the built-in sensor as a baro sensor.

The pressure barb is connected to a full-vacuum source at the intake manifold. When tapping into any existing vacuum ports on a throttle body be sure to select one that gives full vacuum when the throttle is closed. (i.e. not a "ported vacuum" source that would connect to a distributor.)

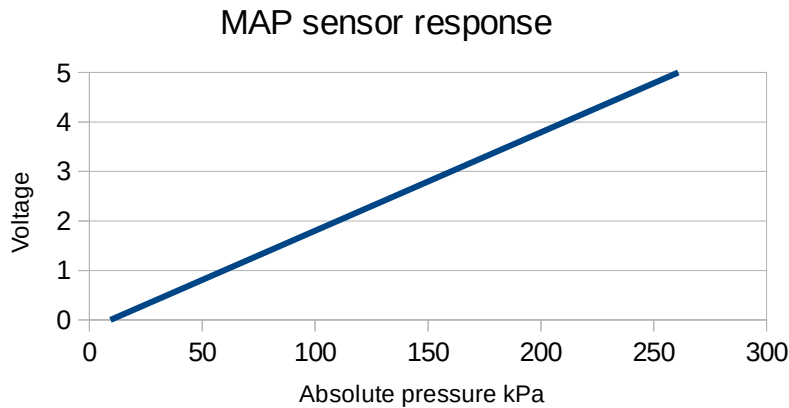

Optionally a second sensor may be installed to measure barometric pressure. This works in the same way but typically a 1-bar sensor is used. The pressure feed port is left open to the atmosphere and will help the engine respond to changes in ambient pressure or elevation.

3.4.3 IAT/MAT (Intake/Manifold Air Temperature) sensor



This external sensor measures the temperature of the air entering the engine. This is used to calculate air density and is a key factor in the Speed-Density fuel calculation.

The temperature sensor is a variable resistor (a thermistor). Higher temperatures give a lower resistance, the response is non-linear.

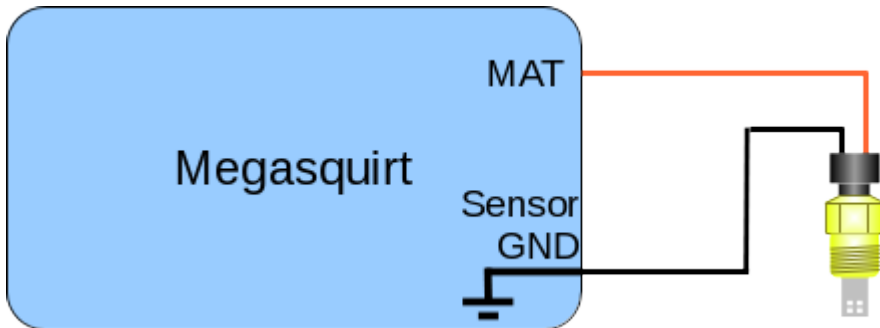

Any install not using a MAT should connect the MAT input to sensor ground to prevent the reading "floating".
A good sensor will have two wires, one wire connects to sensor ground, the other to the MAT input on the ECU.
One-wire sensors are not recommended.

The sensor may either be an "open-element" or "closed-element" type sensor. "Open-element" sensor have a thermistor directly exposed to the air-stream - this type of sensor is required for turbo-charged application where the air temperature can change quickly. The "closed-element" type sensor is identical to a coolant temperature sensor and has an encapsulated thermistor - these respond too slowly for turbo-charged application.

Temperature sensor resistance

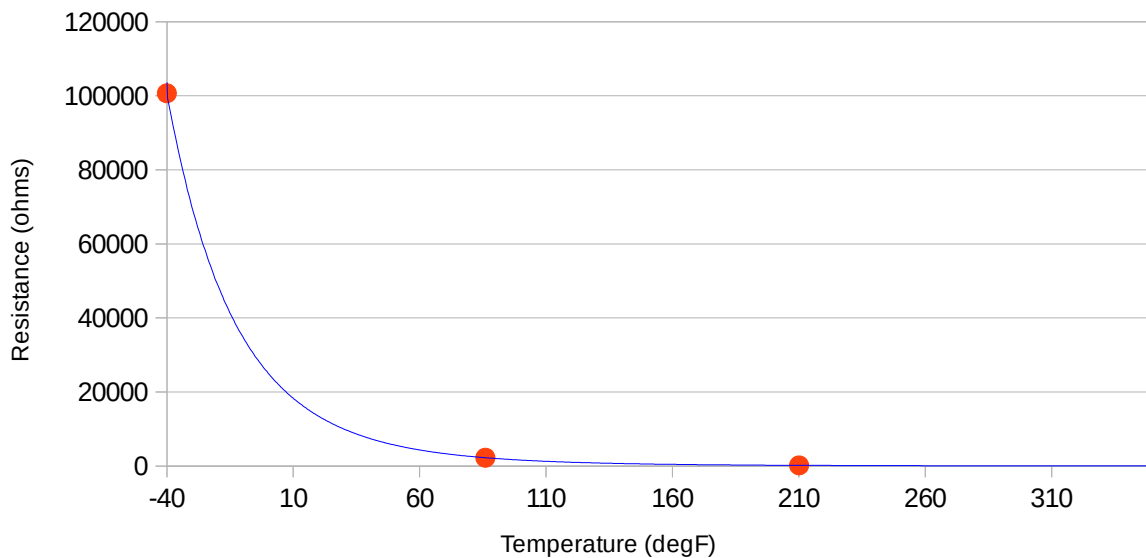

The red dots are the three standard calibration points for GM sensors.

The ECU uses a circuit to convert the resistance into a voltage that it measures.

Temperature sensor signal at ECU

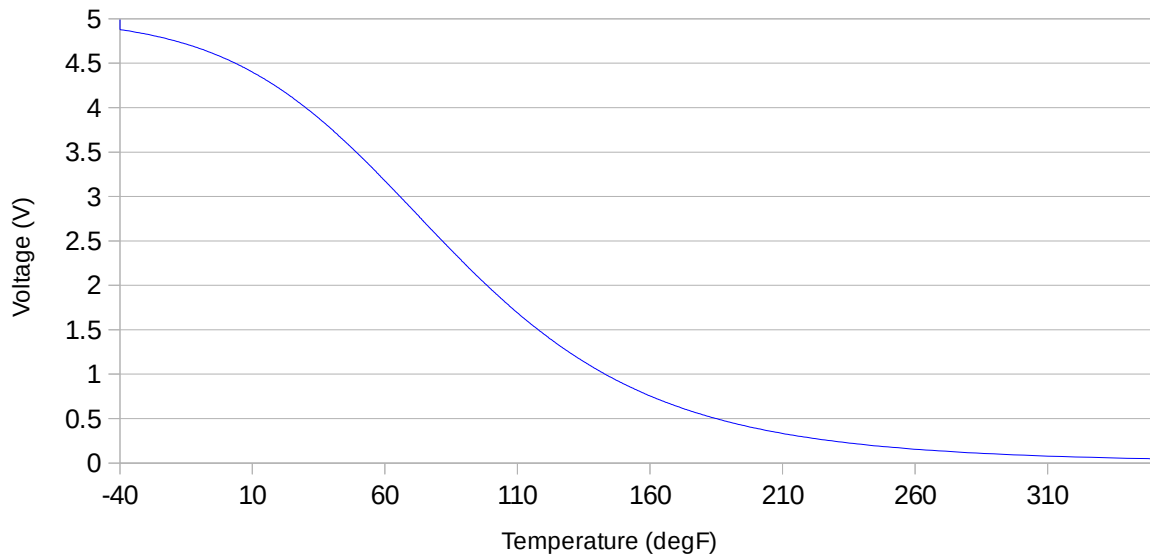

3.4.3.1 Sensor calibration

TunerStudio includes many predefined calibration curves to select from, but for other "unknown" sensors the three calibration points can be determined.

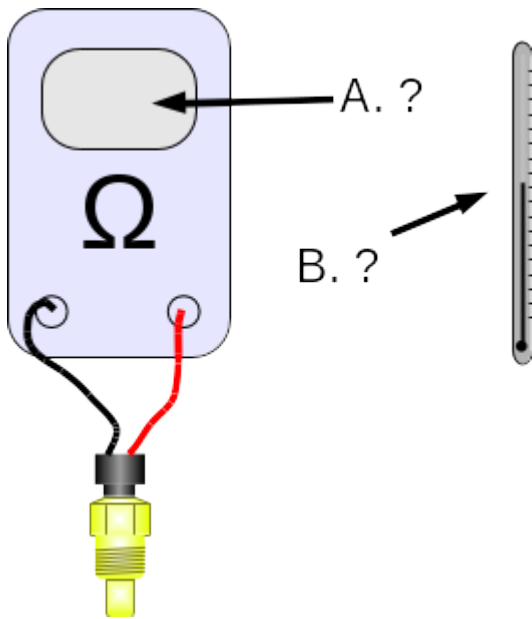

The manual calibration process requires the use of a multimeter set to measure resistance and ideally a thermometer. Without a thermometer your calibration will be fairly close but not perfect.

1. Set the meter to ohms and connect the meter to the two terminals on the MAT or CLT sensor.
2. Allow the sensor to reach room temperature.
3. Take the resistance reading.
4. Measure room temperature using a thermometer (typically 20°C / 68°F)
5. Place the end of the sensor in a mixture of ice melting in water and allow it to stabilize.
6. Take the resistance reading.
7. Measure the ice/water temperature using a thermometer (typically 0°C / 32°F)
8. Place the end of the sensor in a pan of boiling water and allow it to stabilize.
9. Take the resistance reading.
10. Measure the boiling water temperature using a thermometer (typically 100°C / 212°F)

You now have the three calibration points for TunerStudio.

For a GM sensors these should be close to:

Where	°C	°F	Ohms
Ice/water	0	32	9441
Room temp.	20	68	3518
Boiling water	100	212	172

Note that the default calibration data in TunerStudio goes down to -40° but that's rather difficult to measure in the normal workshop.

3.4.4 CLT (Coolant Temperature) sensor



This external sensor measures the temperature of the engine coolant (or cylinder head for air-cooled engines.) It is primarily used to provide additional fuel during engine warm-up.

The coolant temperature is a thermistor and works in the same way as the air temperature sensor.

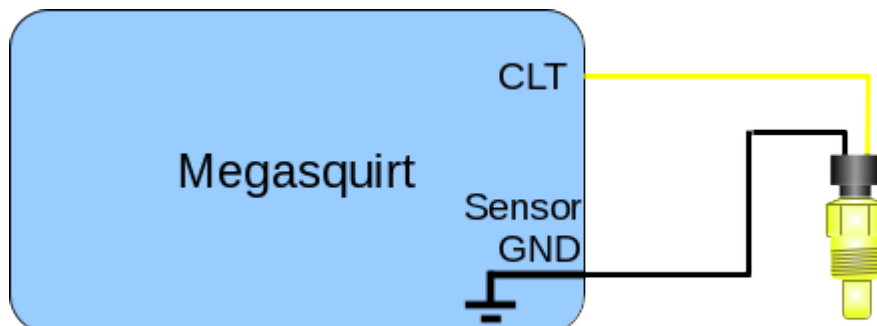

Any install not using a CLT should connect the CLT input to sensor ground to prevent the reading "floating".

A good sensor will have two wires, one wire connects to sensor ground, the other to the CLT input on the ECU. One-wire sensors are not recommended.

3.4.5 TPS (Throttle Position Sensor)

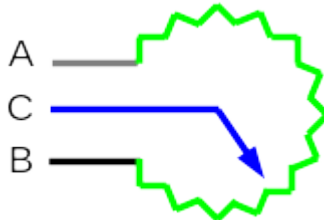
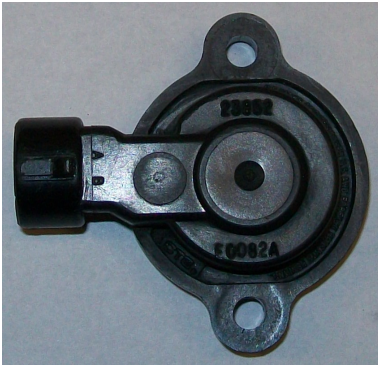

This external sensor measures the position of the throttle plate. It is a variable resistor (potentiometer) and sends a 0-5V signal back to the Megasquirt. The sensor has three wires, 5V supply (TPSVREF), Ground (sensor ground return) and signal. The Megasquirt converts the signal to a 0-100% scale using your calibration numbers. 0% corresponds to fully closed, 100% to fully open.

Switch-type throttle position sensors are not recommended.

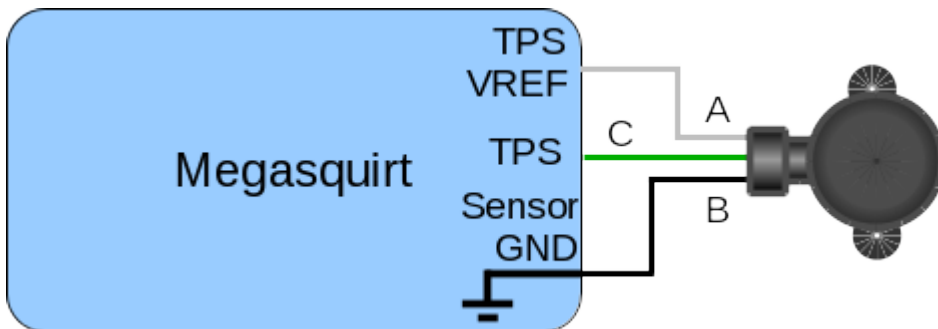

Any install not using a TPS should connect the TPS input to sensor ground to prevent the reading "floating".

3.4.6 O2 (Oxygen) Sensor / Lambda Sensor



1-wire Narrowband



4-wire Narrowband



Wideband

The O₂ / oxygen sensor / lambda sensor input gives feedback on the air:fuel ratio (mixture) of the engine and is screwed into a threaded bung which is welded into the exhaust system. Ensure that there are no air leaks or the readings will be inaccurate.

Narrowband sensors are cheap and very accurate for reading "stoichiometric" mixtures (e.g. 14.7 AFR or 1.000 lambda.) They are widely used by OEMs where the 3-way catalysts require these mixtures for correct operation. They do not give accurate readings under rich or lean conditions.

1-wire narrowband sensors rely on exhaust heat to bring them up to operating temperature and are typically mounted close to the exhaust ports or the "collector" of a cast exhaust manifold.

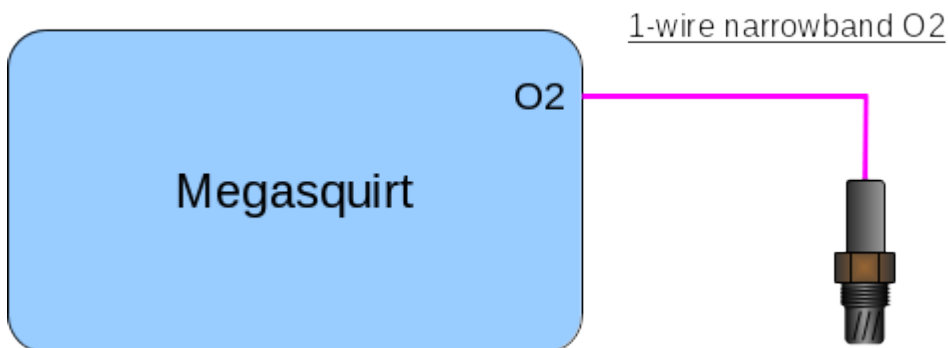

4-wire narrowband sensors include a heater and a signal ground. These can be mounted further away from the exhaust port as they are self heating. Preferable to a 1-wire.

Typical wiring

Blacks = heater power and ground

Blue = signal ground

White = O₂ signal

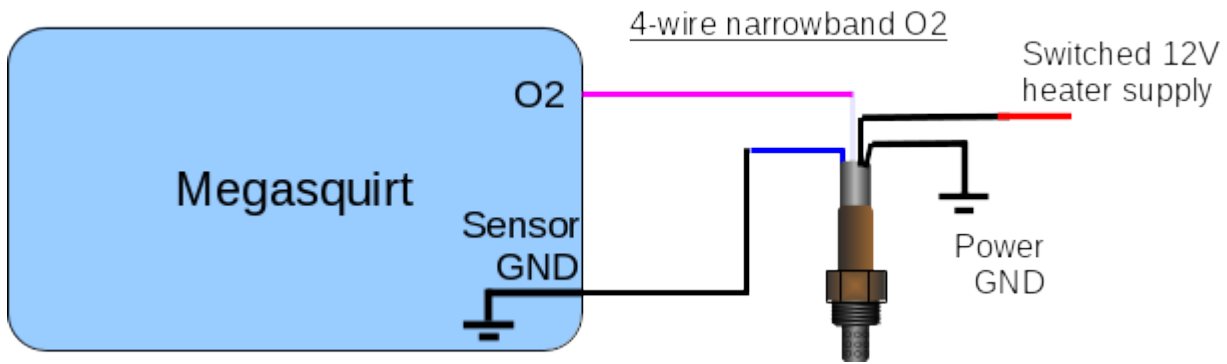

Wideband sensors require an external controller for use with the Megasquirt. Widebands are more expensive than narrowband sensors but give readings over a far wider range of exhaust mixtures. When used with a Megasquirt they give you the ability to tune your engine in the rich (power) and lean (cruise) regions. Strongly recommended.

The better controllers offer a signal ground which should be connected to the Megasquirt sensor ground. Other models require grounding to the engine block only. Consult the directions that came with your wideband controller.

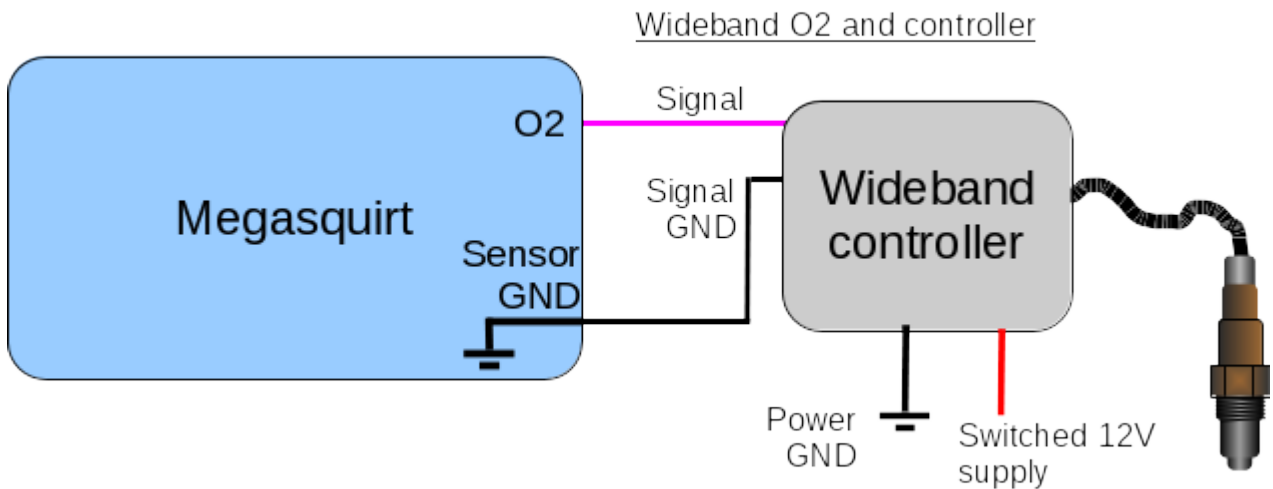

3.4.7 MAF (Mass Air Flow) Sensor



Ford Lightning 6 pin MAF



Nissan Infiniti Q45 MAF

The MAF Sensor measures the actual mass air-flow into the engine. This can be used for a more accurate fueling calculation- other fueling algorithms estimate the mass air flow based on MAP, TPS, RPM, MAT.

MS3 supports voltage MAFs (most common) and frequency MAFs (such as LS1).

3.4.7.1 Voltage MAF

The sensors have at least three wires, 12V supply, Ground (sensor ground return) and signal to the Megasquirt.

To connect a MAF to MS3base/V3.57 internal hardware modifications are required. You may choose from either pin 'JS5 (ADC6)' or 'JS4 (ADC7)' so long as the input port setting in TunerStudio is set to match.

Externally you choose which pin on the main connector is used. Typically SPR3 or SPR4 would be used if they are free.

Parts required. 1k 1/8W (or 1/4W) resistor. 0.22u 10V ceramic capacitor.

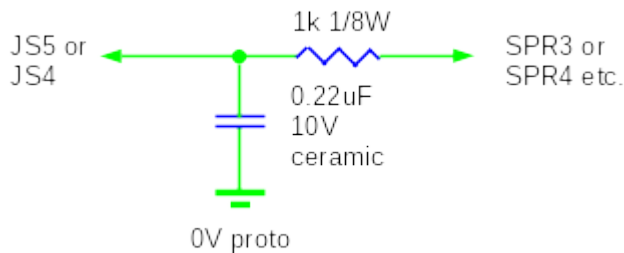

Solder onto some prototype board. Run jumper wire to JS5 or JS4 (your choice.) Run jumper wire to SPR3 or SPR4 (your choice.)

Ford 4 pin MAF

This earlier style MAF has an oval connector.

A = Switched 12 Volts Supply

B = Power Ground

C = MAF Sensor Ground

D = MAF Sensor Signal

Ford - 4 wire MAF

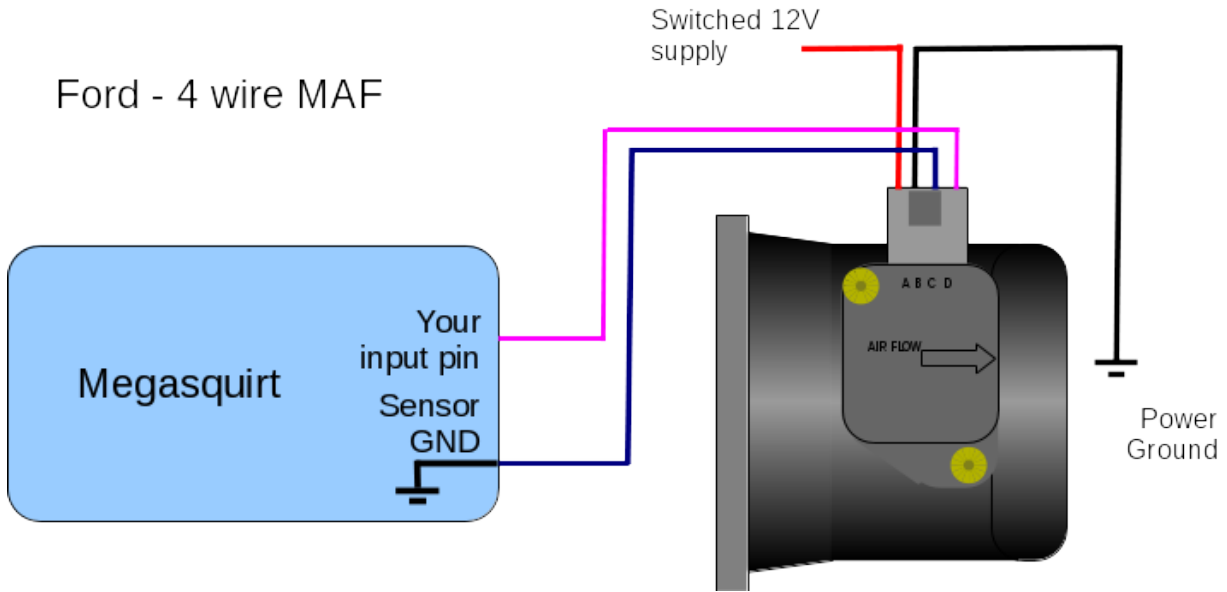

Ford 6 pin MAF

This MAF also includes an intake air temperature sensor, so an additional MAT is not required.

E = IAT Sensor Ground

A = Switched 12 volts supply

B = Power Ground

C = MAF Sensor Ground

D = MAF Sensor Signal

F = IAT Sensor Signal

Ford - 6 wire MAF

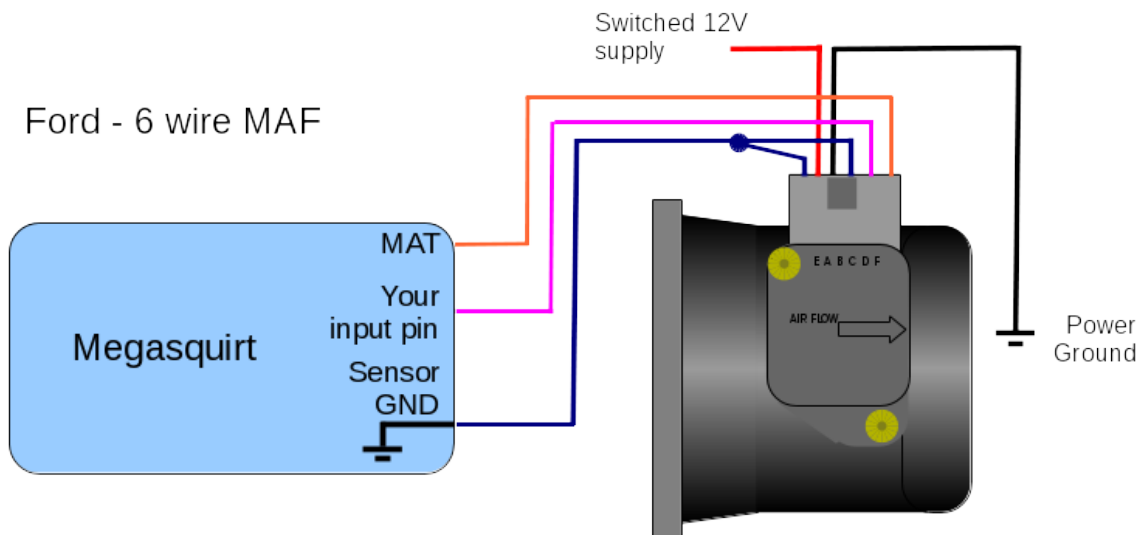

Nissan Infiniti Q45 90mm MAF

B = MAF Sensor Signal (White)

D = Ground (Black)

E = Switched 12 volts supply (Black/white)

Nissan Q45 3-wire MAF

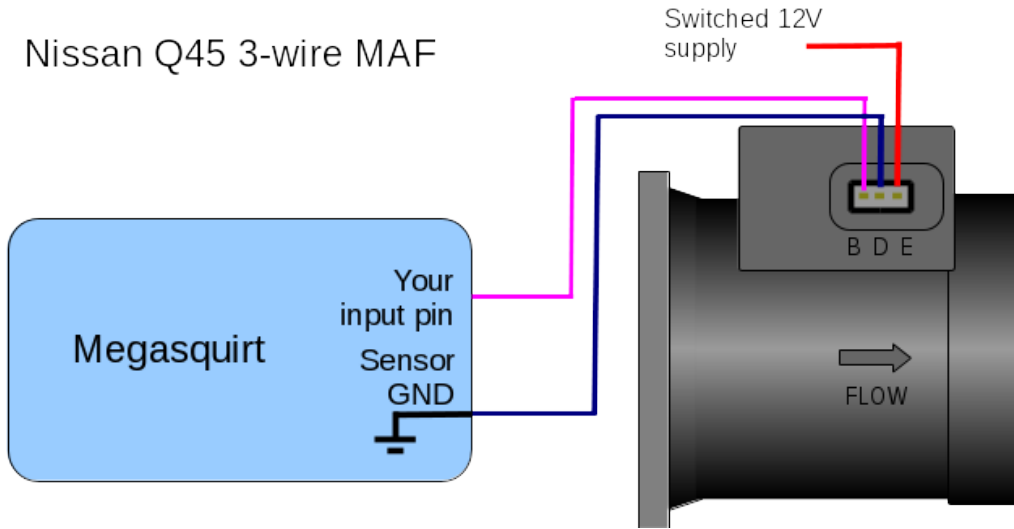

3.4.7.2 Frequency MAF

Many GM (USA) vehicles from 1994 onwards use an AC Delco frequency MAF. (Earlier Bosch units are voltage type.)

The frequency signal has the potential advantage of not being susceptible to any ground differences. Due to the way that the frequency is measured, the reading becomes more coarse at higher frequencies. At 10kHz the measurement has 1% accuracy, 15kHz is 1.5%. For better repeatability, it is suggested to get a larger MAF and recalibrate in preference to running above 10kHz.

The sensors have at least three wires, 12V supply, Ground (sensor ground return) and signal to the Megasquirt.

To connect a MAF to MS3base/V3.57 internal hardware modifications are required. Without the MS3X, pin JS10 is the only option. Set the input port setting in TunerStudio to match.

Externally you choose which pin on the main connector is used. Typically SPR3 or SPR4 would be used if they are free.

Parts required. 1k 1/8W (or 1/4W) resistor. 2x 1N4001 diodes.

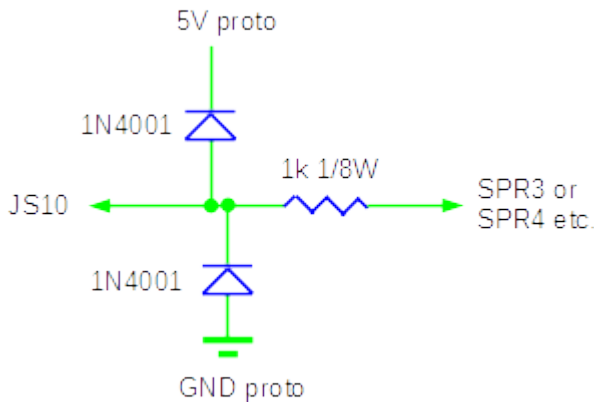

Frequency MAF

Solder onto some prototype board. Run jumper wire to JS10 (your choice.) Run jumper wire to SPR3 or SPR4 (your choice.)

Sensor type	Frequency
Voltage input port	Off
Frequency input port	PT4
Low frequency(Hz)	30.0
High frequency(Hz)	5000.0

Be sure to set the minimum and maximum frequencies before altering the flow curve.
 Pre-defined calibration curves are available for GM LT1, LS1, LSx MAFs.
 When using the 650g/s file (~800hp) set the min/max frequencies to 1000Hz and 11500Hz
 When using the 1300g/s file (~1600hp) set the min/max frequencies to 1000Hz and 14125Hz
 For larger flowing MAFs a custom calibration will be required.

GM 3 wire MAF (1994-2000)

GM 3 wire MAF

- A = MAF Sensor Signal (Yellow)
- B = Power Ground (Black/white)
- C = Switched 12 volts supply (Pink)



C B A

GM MAF sensors require a 1k pullup resistor to be installed between the signal output and 5V.

GM 3-wire MAF

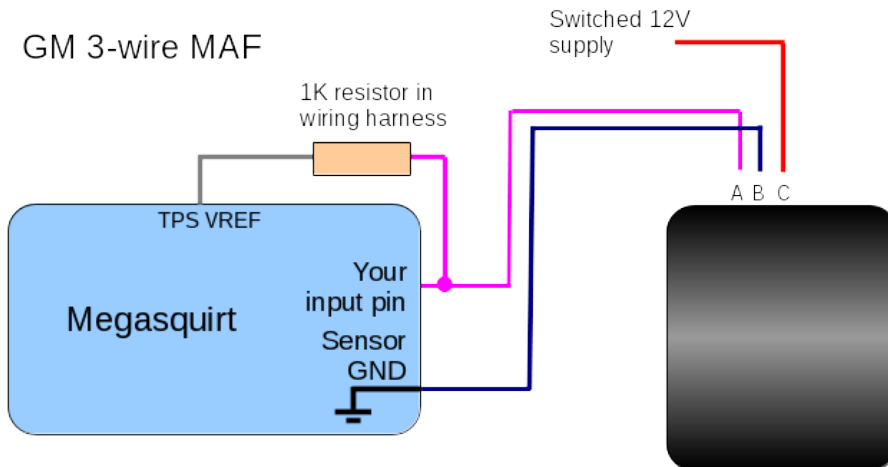

GM LS1 5 wire MAF (2001-2006)

This MAF also includes an intake air temperature sensor, so an additional MAT is not required.

GM LS1 5 wire MAF

Pinout is provided for reference only – double check your application.
 LS3/LS7 believed to be different.



A B C D E

- A = IAT Sensor Ground
- B = IAT Output Signal
- C = Power Ground
- D = Switched 12 volts supply
- E = MAF Sensor Signal

GM LS1 5-wire MAF

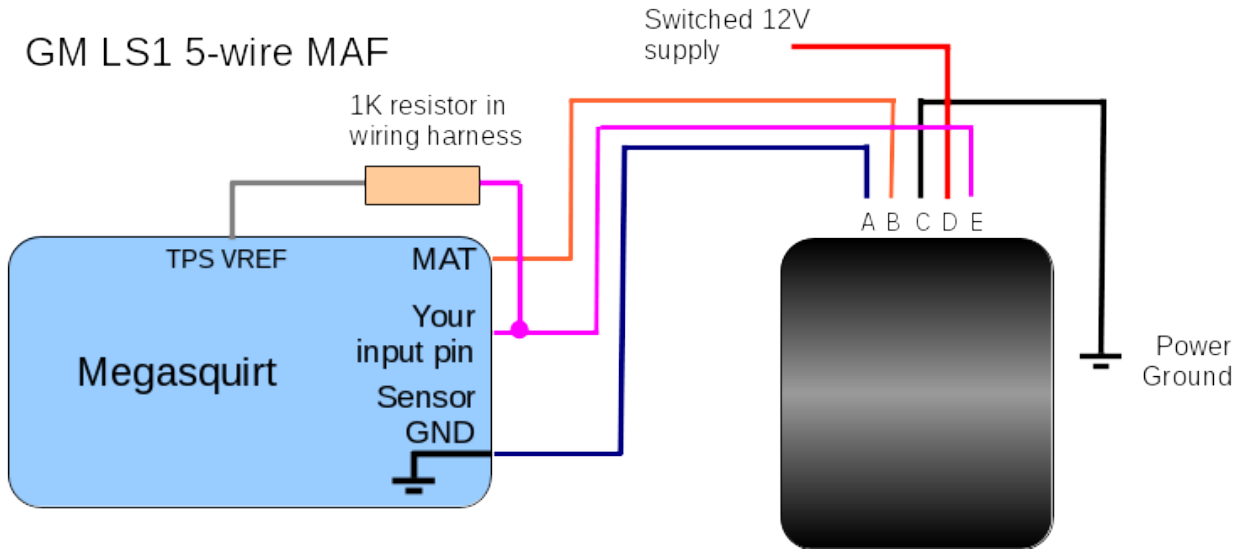

3.4.7.3 MAF flow curve

The flow response of MAF sensors is non-linear and uses a calibration tuning curve in the Megasquirt to convert the input signal into a grammes/second flow rate number.

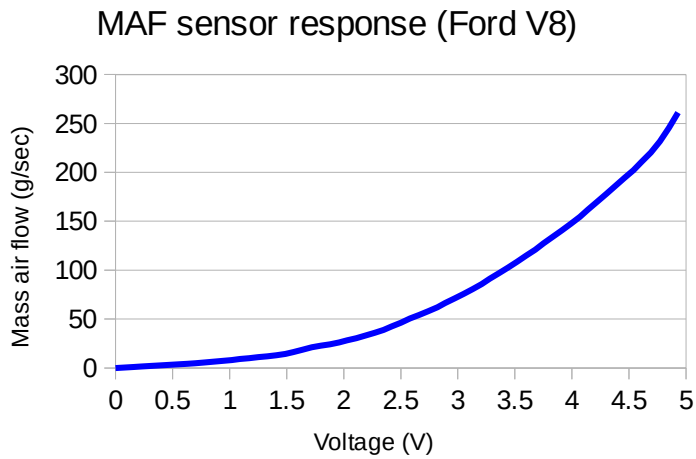

3.4.8 Flex / Switch input



The Flex fuel (or fuel composition) sensor detects the percentage of ethanol within the fuel passing through it. This can be used by the Megasquirt to automatically adjust fuel and spark to allow for the change in fuel. Higher ethanol blends require more pulsewidth and additional spark advance.

The GM sensor (shown) uses barbed pipes, the Ford sensor uses screw in fittings.

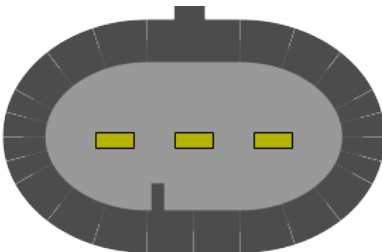

GND 12V Signal

Looking into sensor connector from left.

Ground (GM = white, Ford = Black)

+12 Volt supply (GM/Ford = pink)

Output signal, (GM = purple, Ford = white)

GM and Ford appear to use the same sensor but the letters on the connector may be different.

To connect a Flex Fuel sensor to MS3base/V3.57 internal hardware modifications are required. You may choose from either pin 'PE0/JS7' or 'JS11' so long as the input port setting in TunerStudio is set to match.

Externally you choose which pin on the main connector is used. Typically SPR3 or SPR4 would be used if they are free.

Parts required. Two 10k 1/8W (or 1/4W) resistors.

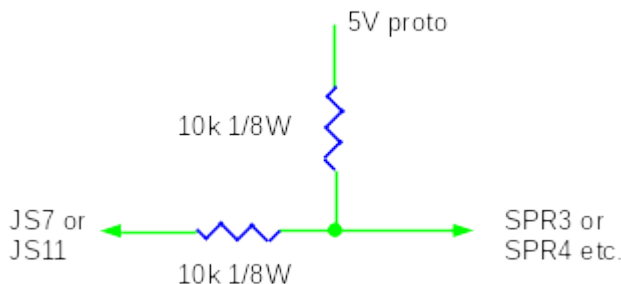

Solder onto some prototype board. Run jumper wire to JS7 or JS11 (your choice.) Run jumper wire to SPR3 or SPR4 (your choice.)

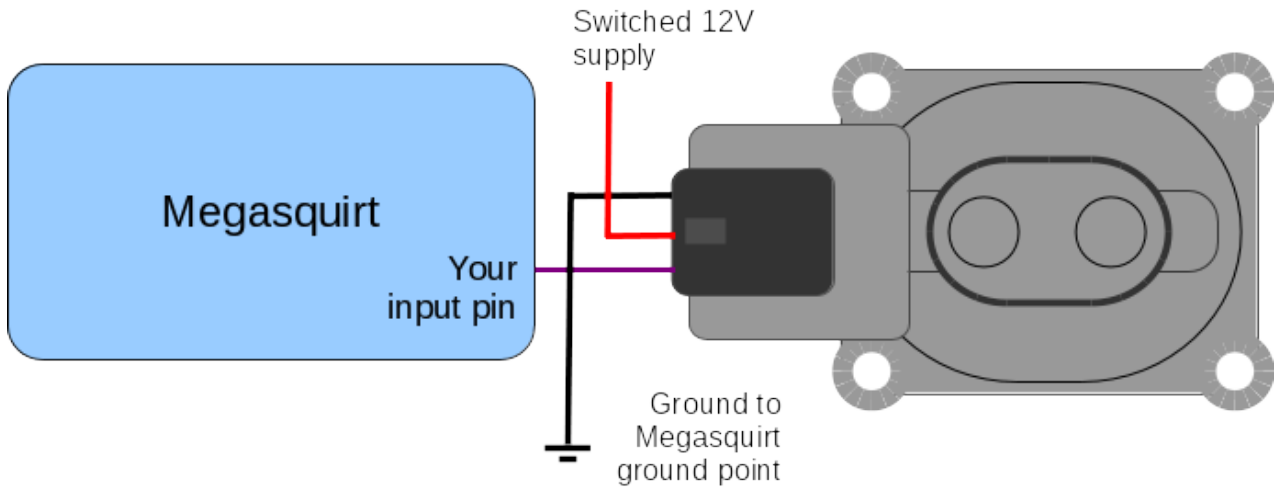

3.4.9 Spare Analog (ADC) inputs

The JS4, JS5 connections on the MS3 card can be used as 0-5V analogue inputs. The Generic Sensors system should be used to translate the raw ADC value into useful temperature or pressure numbers.

Parts required. One 1k 1/8W (or 1/4W) resistor, one 0.22uF 10V ceramic capacitor.

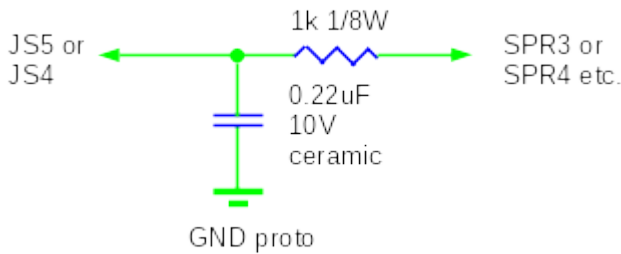

Solder onto some prototype board. Run jumper wire to JS4 or JS5 (your choice.) Run jumper wire to SPR3 or SPR4 (your choice.)

Analogue options: MAF, 2nd O2 sensor, Baro sensor, misc sensor.

Input pin name	Processor (DIP40) pin number	Note
JS4/AD7	30	Analogue input or digital input
JS5/AD6	29	Analogue input or digital input

Analogue options: MAF, 2nd O2 sensor, Baro sensor, temperature sensor, pressure sensor, potentiometer.

Temperature sensor input - with bias resistor on MS3X card

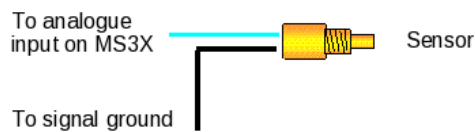

Temperature sensor input - without bias resistor on MS3X card

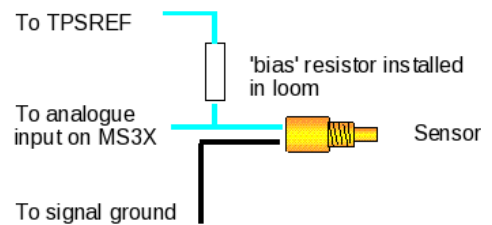

Potentiometer type sensor

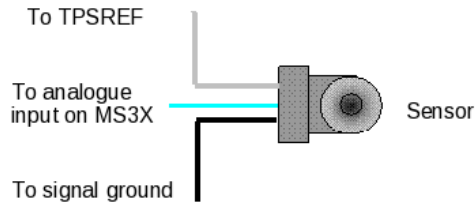

5V pressure sensor input

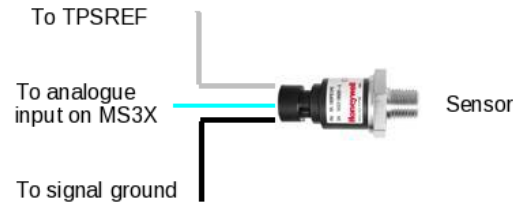

Typical pressure sensor



This is a pressure sensor from Honeywell with a 1/8"NPT thread and a plug the same as GM TPS plugs. The sensor takes a 5V supply (from TPS REF), signal ground at the Megasquirt and gives a 0-5V output (actually 0.5 to 4.5V).

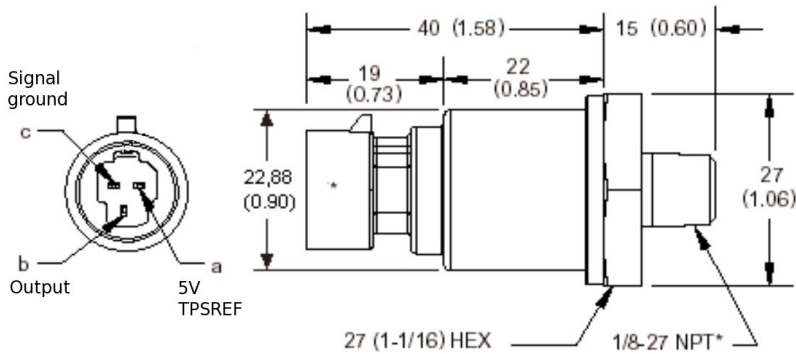

3.4.10 Switch inputs

Switch input options: Launch input, nitrous input, shift cut input.

These features all require a ground at the MS3 card to activate the feature. All require internal hardware modifications.

The simpler modification is for a ground switched input. (Recommended.)

A 12V switch input requires more components.

As with other inputs, you choose which MS3 pin to use and which main connector pin to use.

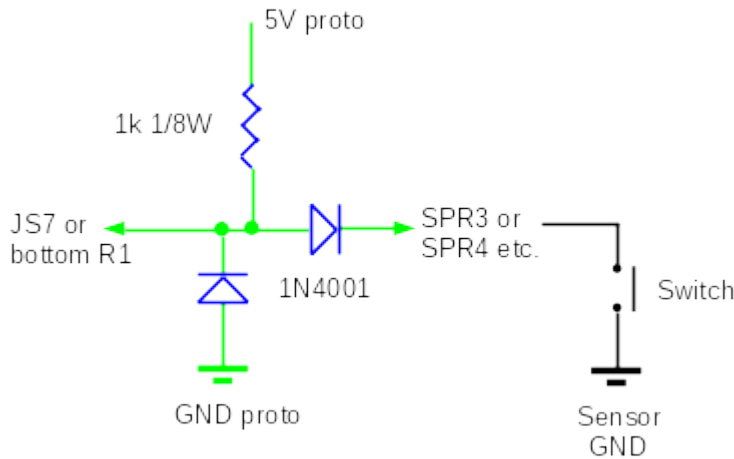

Ground switch input

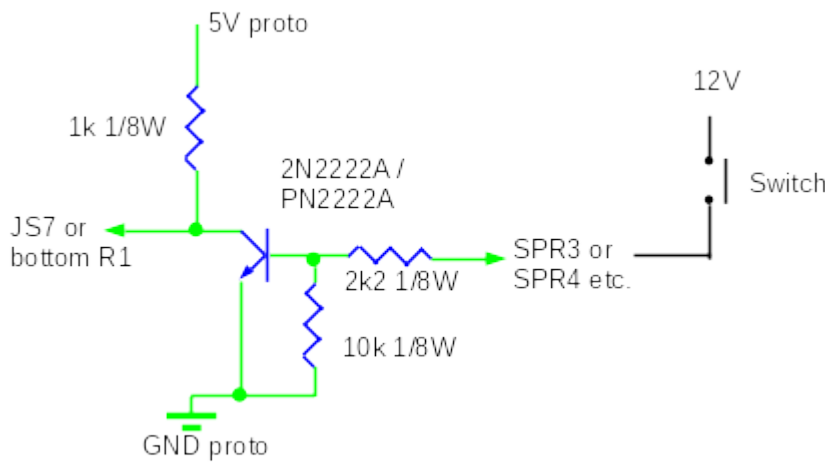

12V switch input

Input pin name	Processor (DIP40) pin number	Note
JS4/AD7	30	Analogue input or digital input/output.
JS5/AD6	29	Analogue input or digital input/output.
JS10	17	Digital input/output
JS11	18	Digital input/output
JS7/PE0	10	Digital input only.
PE1	15	Digital input only.

See the specific feature for information on how to configure the inputs.

3.4.11 B/LD boot jumper

The B/LD jumper on the MS3 card is shorted (with a shunt) to force the Megasquirt into "bootloader" monitor mode. This is only typically needed when loading the firmware for the first time. It can optionally be used if the firmware has become corrupted (e.g. an ignition spike got into the wiring harness) and the normal firmware loading will not function.

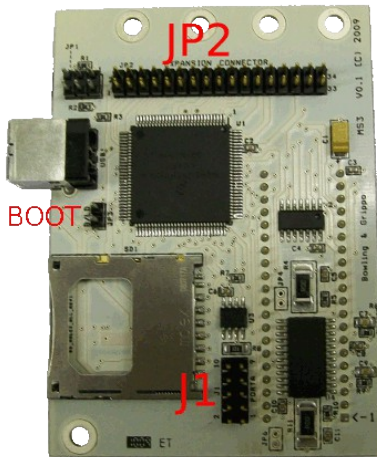

3.4.12 CAN comms

The CANH/L wires are used to connect to add-on units such as transmission control, CANEGT interfaces, data capture or compatible dashboards.

The Megasquirt includes a terminating resistor.

To use the CAN connections, you need to run internal jumper wires as per section 13.4.

JS6 -> SPR1 = CANH

JS8 -> SPR2 = CANL

In general, CAN forms a bus network with a 120R terminator at each end and devices wired as short 'drops' off the network.

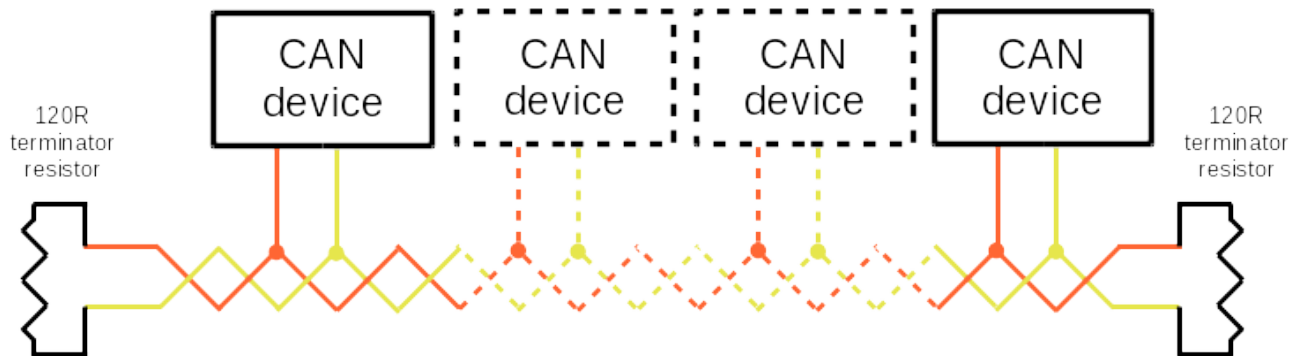

The Megasquirt includes a terminating resistor internally, so no additional resistor is required at that end.

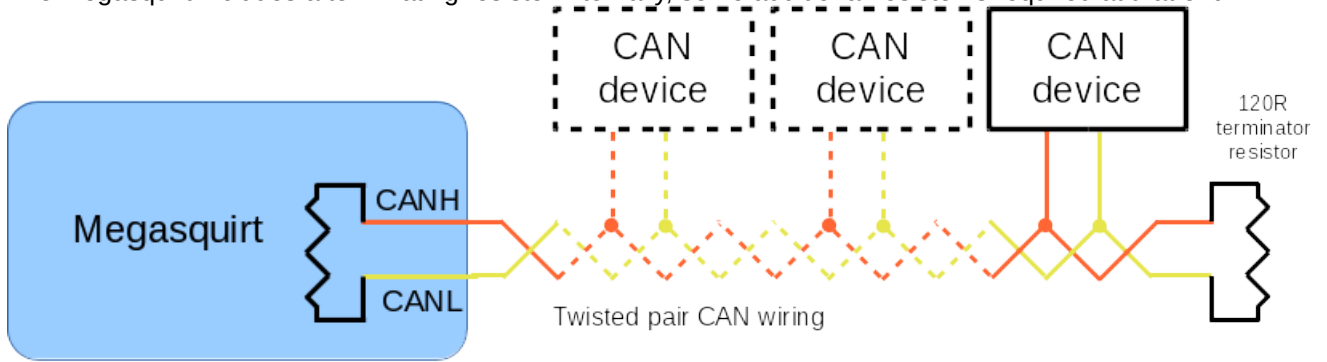

3.4.13 Knock sensor

Megasquirt supports knock sensing with an internal or external interface to the knock sensor.

You can only connect a sensor directly to the Megasquirt when the internal knock module is installed.



Three configurations are available - on/off, analogue or internal

The **on/off mode** can be used with a GM ESC module (16022621, 16052401)

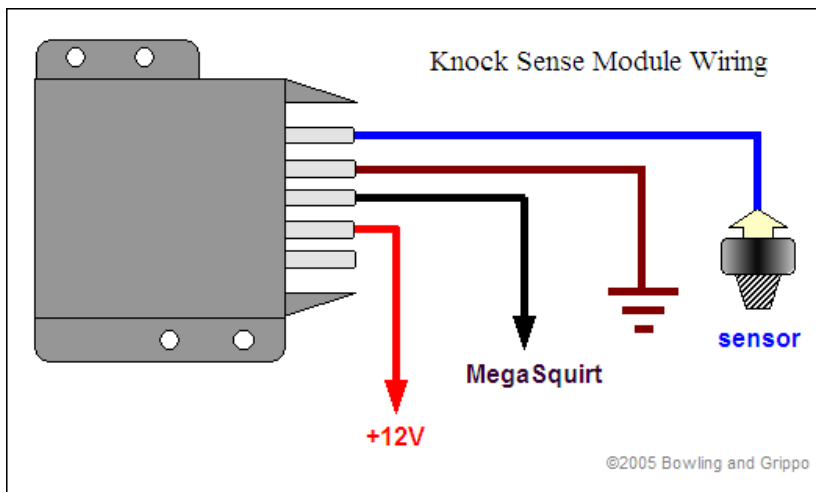

The connection to the Megasquirt is on JS4 or JS5. A circuit will need to be built on some prototype board as there is no prototype area on the V3.57 mainboard.

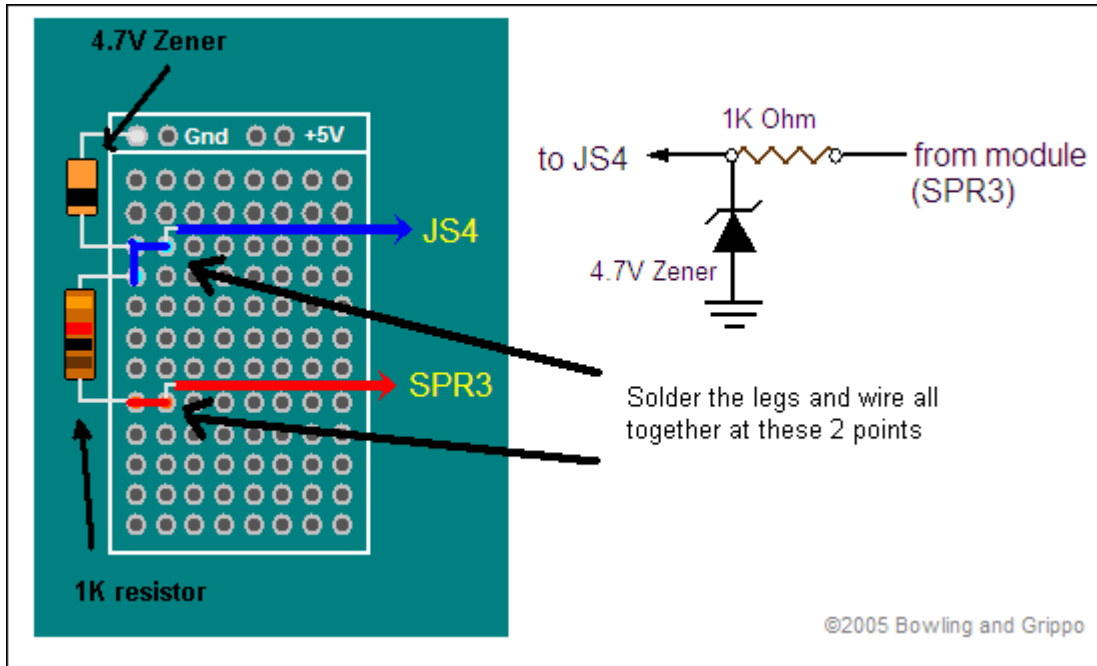

In the **analogue mode**, 0-5V signal is fed into JS4 or JS5 using a protective circuits as in 3.4.9.1.

In the **internal mode**, an add-on card is required. This gives superior knock-sensing control with software control. It allows per-cylinder detection and tuning to specific engine bores size.

However, the add-on requires that the MS3X spark outputs are used and is not compatible with the "LED" spark outputs when the MS3 is used without. See the MS3X/V3.0 manual for more details.

3.4.14 Speed sensor inputs

The speed sensors system expects to receive a 0-5V pulsed signal internally at the processor.

With some DIY, the spare inputs internally on the mainboard can be used with a suitable interface circuit - such as switch input shown in section 3.4.10 or this 12V safe input. This is equivalent to the PT4 input circuit on the MS3X expansion card.

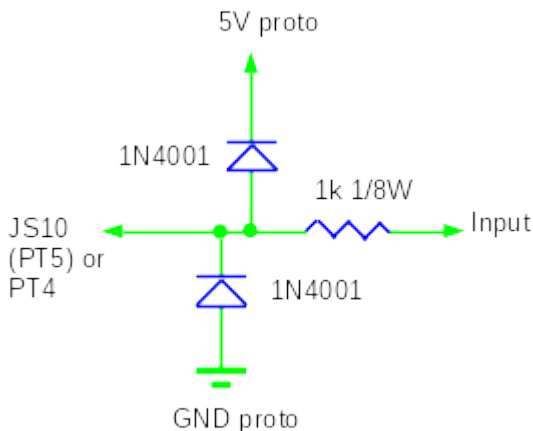

VR sensors will need a suitable interface circuit to convert the AC signal into a 0-5V pulsed signal.

3.4.15 EGT input



K-type thermocouple probe and bung.

For multiple channels of EGT, an external solution such as the "CANEGT" add-on device is likely the best choice.

For a single channel, it is possible to DIY a solution. Build the following circuit on some strip-board. Connect both EGT sensor wires out through spare pins on the main DB37 plug or the DB15 plug.

This circuit gives 0V = 0°C and 5V = 1250°C (2282°F)

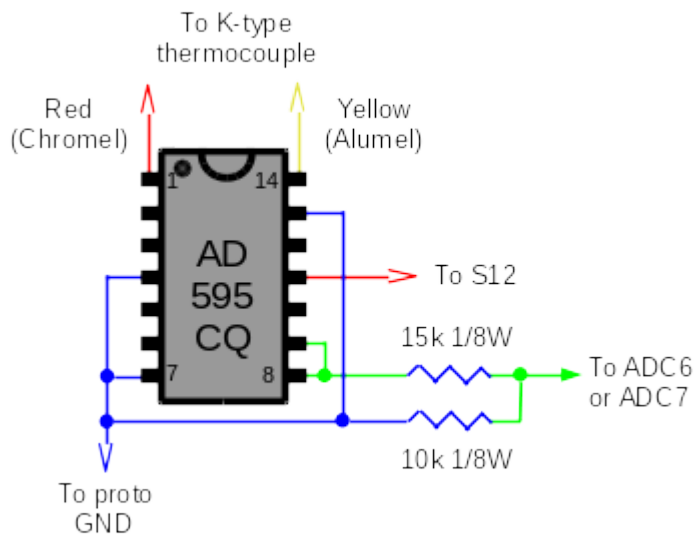

Sensor wire colors

Wire name	ANSI color	IEC color	BS colour
Chromel (-)	Red	White	Blue
Alumel (+)	Yellow	Green	Brown

3.5 Outputs

3.5.1 Fuel Injector outputs



The Megasquirt mainboard has two injector outputs. These can supply up to 14A maximum each. Typically this allows up six injectors per channel. MS3/V3.57 supports both hi-z (14 ohm) and low-z (e.g. 2.5 ohm) injectors directly.

The MS3X connector has eight injector outputs. These can supply up to 5A maximum each. Typically one hi-z injector is used per channel. Injector resistors or an external peak&hold box are required for low-z injectors.

Fuel injectors are covered in more detail in section 4.

3.5.2 Ignition outputs



The MS3X connector has eight 0-5V logic ignition outputs.

Ignition outputs and the ignition system are covered in more detail in section 5.

3.5.3 Fuel pump output

The Fuel Pump output is low current low-side output used to drive a relay that switches the high current fuel pump. The coils and injectors should also take power from this relay so that when the engine is shutdown or stalls these are positively disconnected from power.

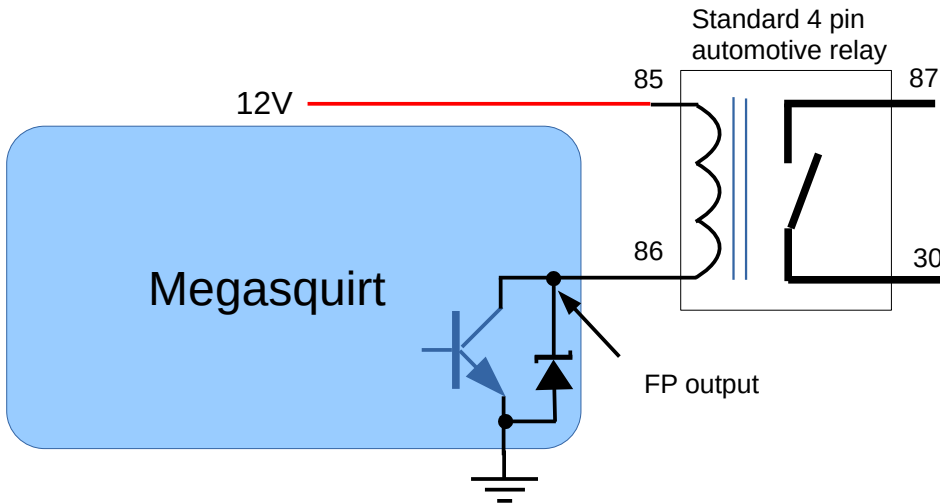

3.5.4 Idle valve

An idle valve is used to allow additional air into the engine, bypassing the throttle plate. This works similarly to the part of the choke mechanism on a carburettor and raises idle speed during warmup. Additionally it can be used for "closed-loop idle" to maintain a steady idle RPM under varying engine loads (lights on vs. off etc.)

As standard, the MS3/V3.57 supports on/off type valves and stepper idle motors. Servo type idle valves are not currently supported.

3.5.4.1 On/Off Idle Valve

The output can be used to operate a relay to drive the idle valve.

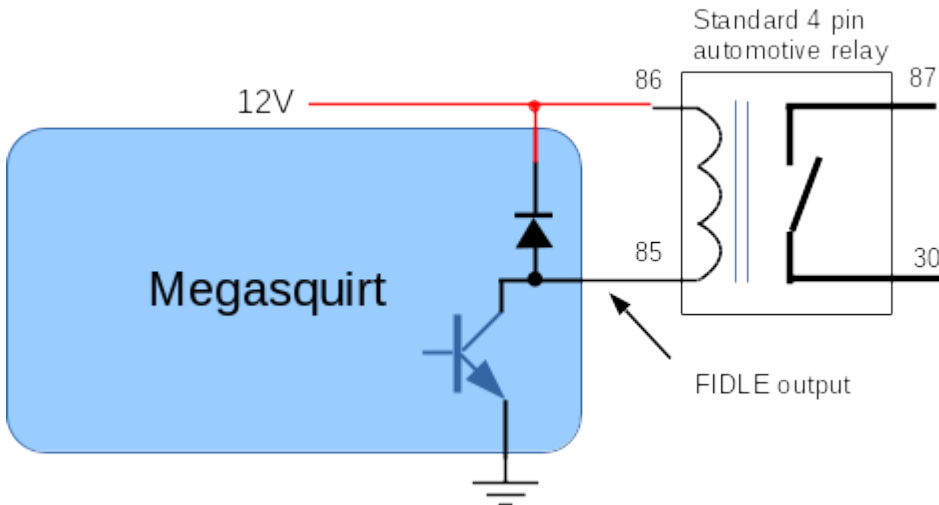

3.5.4.2 2-wire PWM idle valve

2-wire PWM idle valves are used by Ford, VW, Volvo and many others. The MS3/V3.57 can drive this type of valve directly.

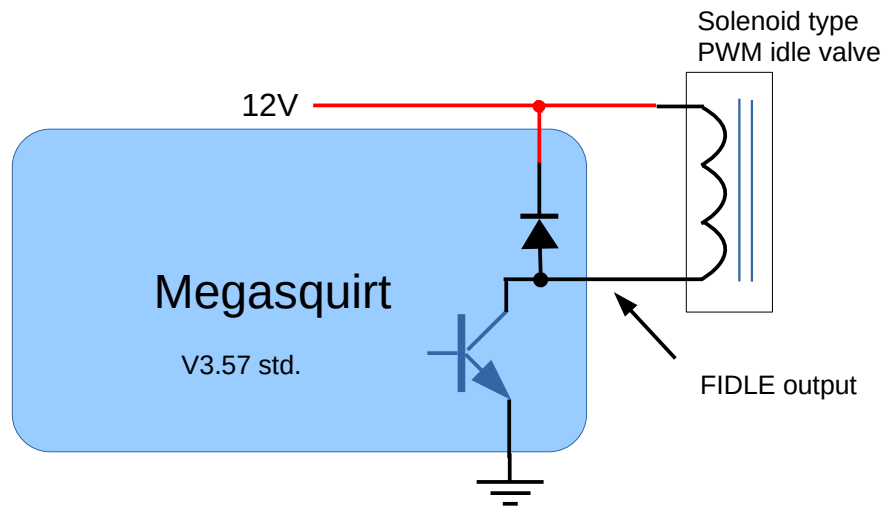

The 12V supply for the idle valve must be a fused switched supply - ideally from the fuel pump relay. It must never be supplied power when the Megasquirt is off.

3.5.4.3 4-wire or 6-wire stepper idle valve



4-wire stepper idle valves are common on many GM vehicles. MS3 can control these directly. All that is required is that internal jumper wires are installed internally as per section 13.4

- a) JS0 to IAC1A
- b) JS1 to IAC1B
- c) JS2 to IAC2A
- d) JS3 to IAC2B
- e) JS9(+12V) to S12C

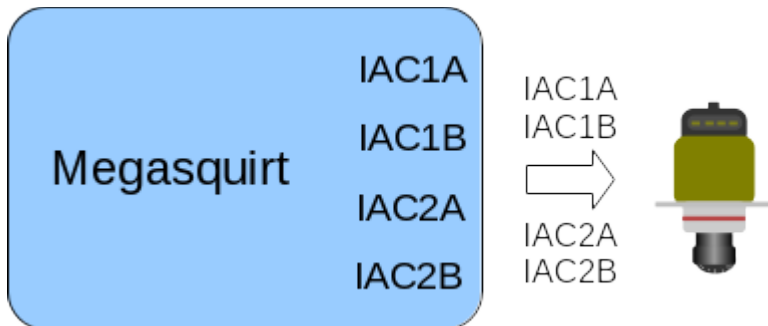

The 4-wire stepper motors commonly used by GM are "bi-polar" type.

IAC Wiring Diagrams

Note: In-line (0-ring) stepper can have two possible wiring arrangements. Use an ohmmeter between the two center pins - if you get ~50 Ohms, use the first diagram. If you get an 'infinite' reading, use the second diagram.

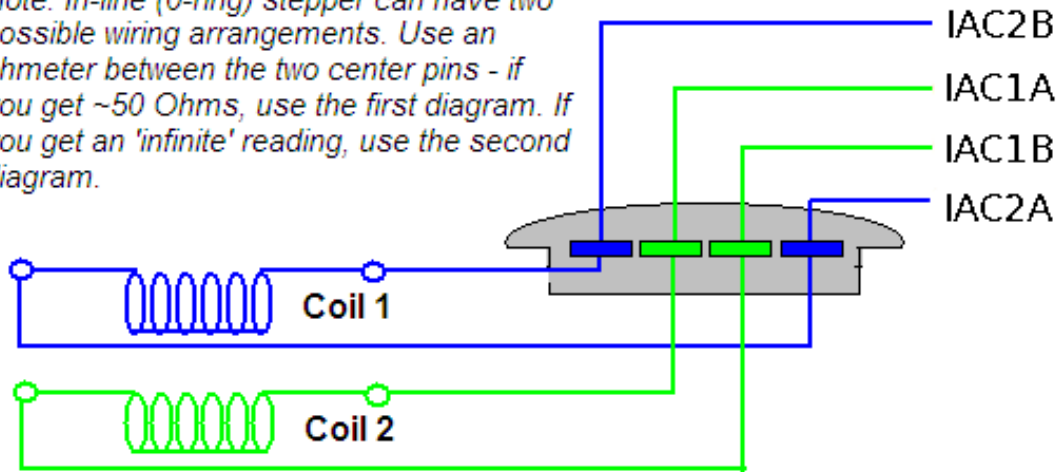

OR
Most common

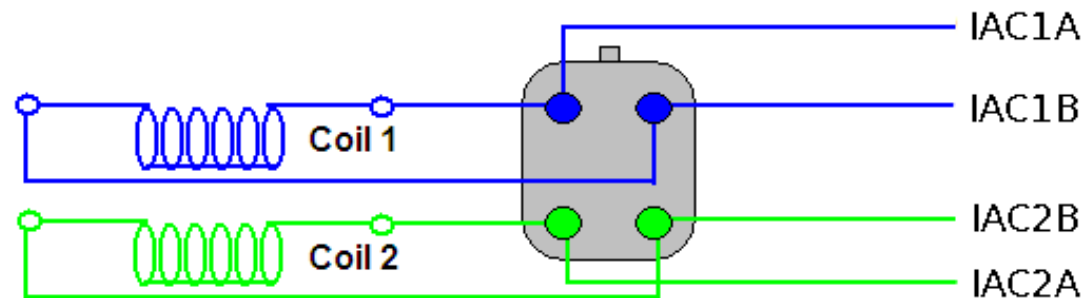
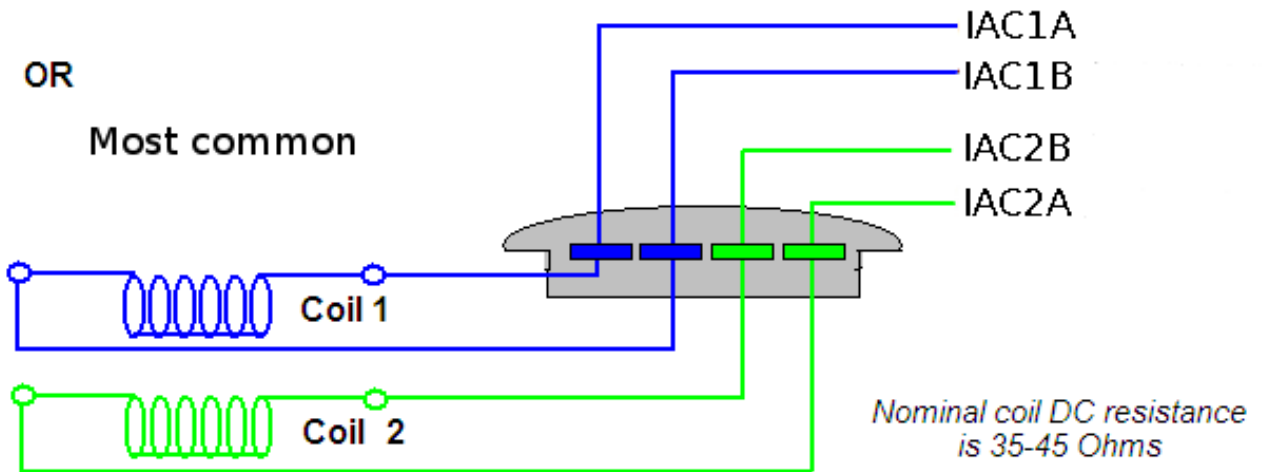

Viewed looking at IAC, not connector.

Arr. ©2005 - Bowling and Grippo

Other manufacturers use 5- or 6-wire steppers which are uni-polar.

These are usually wired as shown in the schematic below, with a center tap on each of two windings. In use, the center taps of the windings are typically wired to the 12V supply, and the two ends of each winding are alternately grounded to reverse the direction of the field provided by that winding.

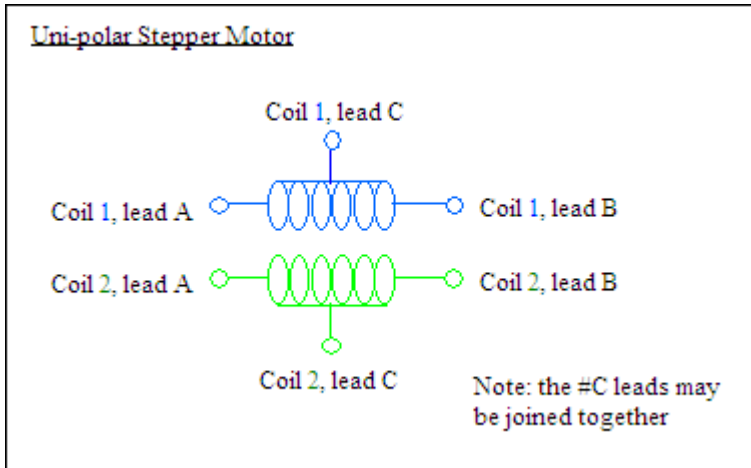

3.5.5 Tacho output

A tacho output typically provides a 0-12V pulsed signal that is suitable for driving an aftermarket tachometer (rev counter.)

Some older tachometers expect the high-current "spike" from the ignition coil and may not work directly with a 0-12V signal.

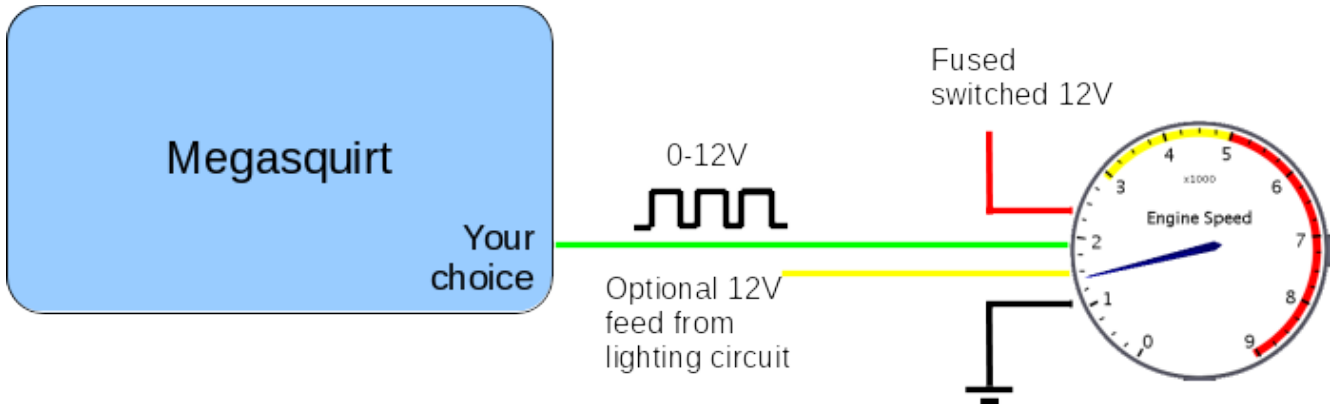

Outputs IAC1A, IAC1B, IAC2A, IAC2B provide a 0-12V signal. If these are not used for a stepper idle valve, they could be used directly for a tacho output. Ensure that the jumpers in section 13.4 are connected.

For other tacho output options, internal hardware modifications will be required.

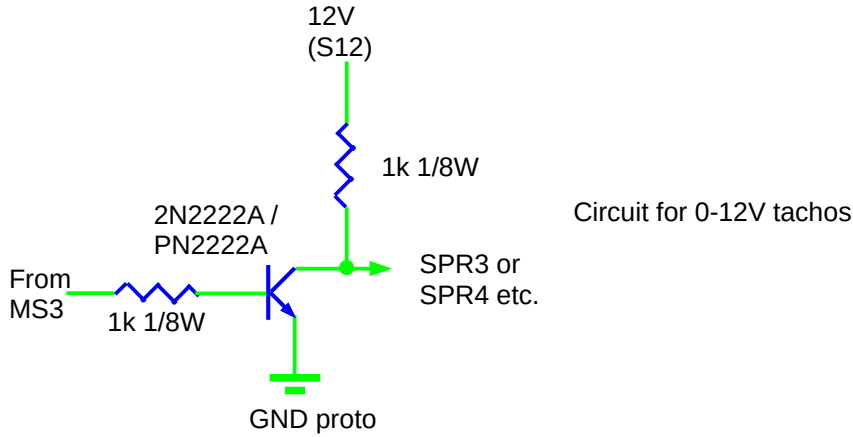

High-voltage tachometer can use a relay coil to generate the voltage "spike" they require. It is suggested that the mechanism inside the relay is removed or it will buzz loudly!

Alternatives to 2N2551 are ZTX458, MPSA42

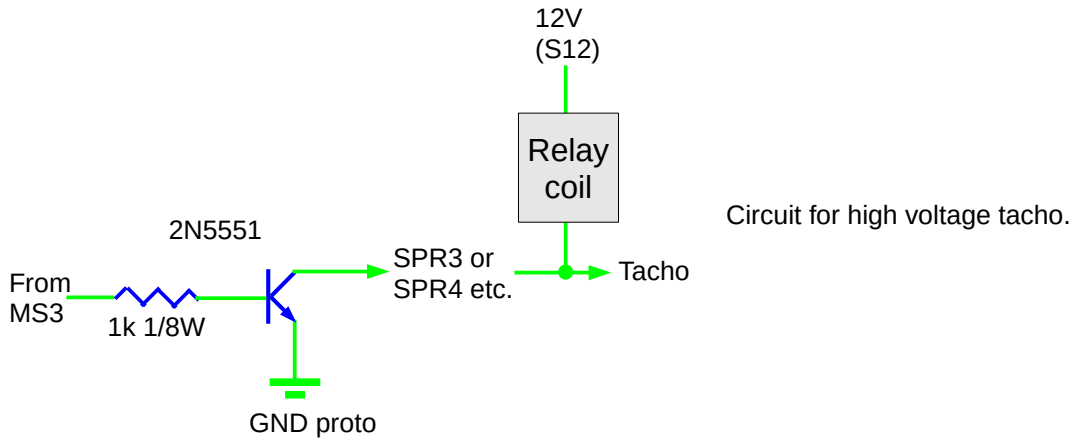

3.5.6 Other relay outputs

Other pins on the MS3 card can be reconfigured as outputs. Internal hardware modifications will be required.

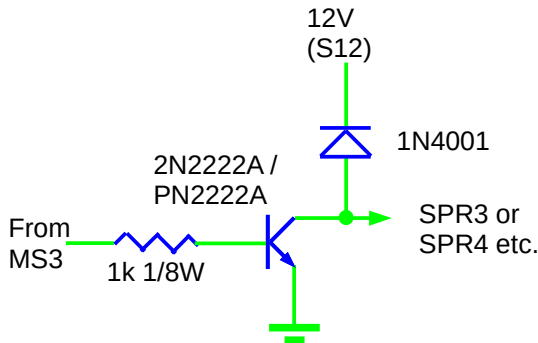

The "From MS3" connection is the specific CPU pin that you choose in TunerStudio.

Output pin name	Processor (DIP40) pin number	Note
IAC1/JS0	38	0-12V output.

IAC2/JS2	36	0-12V output.
JS4/AD7	30	Analogue input or digital input/output.
JS5/AD6	29	Analogue input or digital input/output.
JS10	17	Digital input/output.
JS11	18	Digital input/output.
D14	7	Digital output.
D15	9	Digital output.
D16	8	Digital output.
FIDLE	34	Digital output.

3.5.7 Boost control output

The boost control output requires a higher current transistor such as the TIP122. This needs a mica or similar insulator. Ensure that that 12V feed to the boost solenoid is supplied from the fuel pump relay or backfeeding may occur.

This same circuit could be used to drive a small bulb such as a shift light instead of the solenoid.

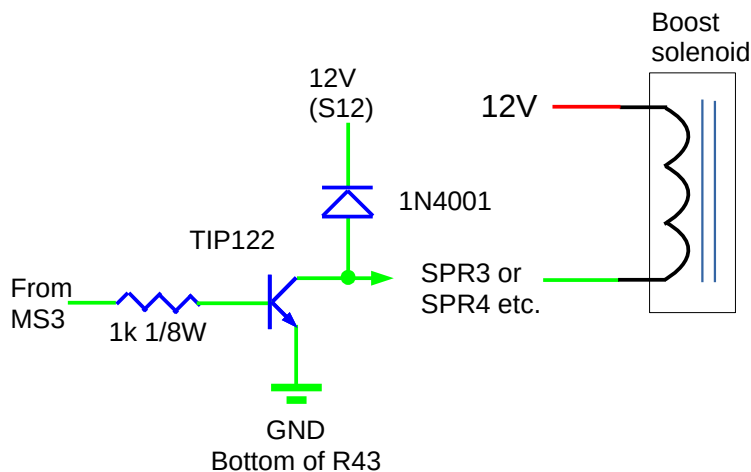

3.5.8 Alternator control wiring

The software settings for alternator control are covered in the TunerStudio reference manual.

Traditional alternators had their voltage maintained by the regulator which was either internal or external. In recent years there has been a move to use computer controlled alternators where the engine ECU controls the operation to optimise battery life and gain a little fuel economy.

Different OEMs use different control methods for their alternators. Some OEMs send a signal to the alternator demanding a particular voltage, others have the control function within the ECU itself.

The "Warning Lamp Output" is optional but strongly recommended - use a spare mid-current output to drive a dash bulb. Typical wiring is shown in section 3.5.6.

3.5.8.1 Ford alternators

From 1999 onwards, Ford has used ECU controlled alternators on some/all vehicles. There are three additional connections on the alternator.

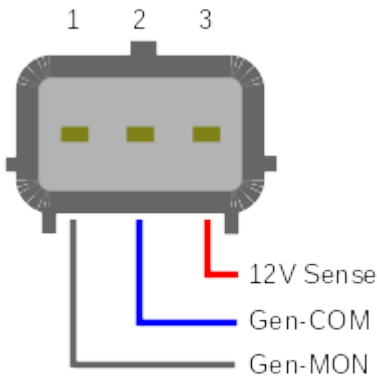

- SENSE (or A or S) - this connects to battery voltage typically near or at the battery.
- GEN-COM (or GEN RC or SIG or RC) - this is the 'command' signal from the ECU to the alternator. Internally the alternator pulls this to battery voltage through a 1K resistor.
- GEN-MON (or GFS or FR or LI) - this is the 'monitor' signal from the alternator back to the ECU. The alternator switches this to ground, it connects to a 0-5V frequency input on the ECU with a pullup resistor.

On the Ford Focus 98AB19399DF alternator tested, pin 3 (SENSE) was red, pin 2 (GEN-COM) was blue and pin 1 (GEN-MON) was grey.

Ford uses a variable frequency system to set the alternator voltage.

Target Voltage	Period	Freq (ref)
12.0V	0.5ms	2000Hz
12.8V	3.4ms	294Hz
13.6V	6.3ms	159Hz
14.4V	9.3ms	108Hz
15.2V	12.2ms	82Hz
16.0V	15.1ms	66Hz

Current firmware 1.5.x is programmed by time period. (Previous firmware 1.4.x was programmed by frequency and had a maximum of 250Hz)

If no signal is sent or a voltage of 12.0V is commanded, the alternator does not charge.

ECU voltage control

To operate the alternator, the GEN-COM wire (pin 2) connects to a mid-current/relay output (see section). No connection is required to the GEN-MON wire (pin 1).

Settings

Control Mode: Open loop frequency

Control Output: high or mid current output of your choice to match your wiring

Output Polarity: Normal

A warning lamp may be configured.

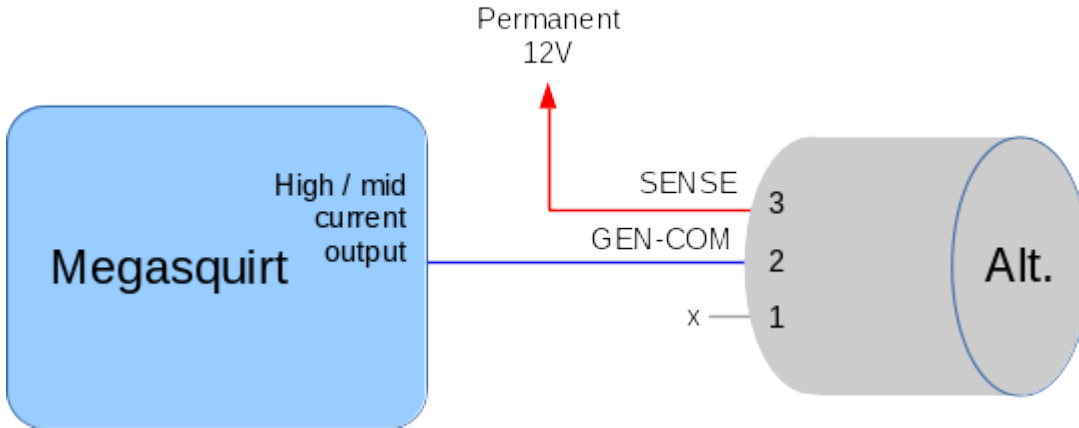

ECU voltage control with load monitor

To operate the alternator, the GEN-COM wire (pin 2) connects to a mid-current/relay output (see section). The GEN-MON wire (pin 1) connects to a 0-5V frequency input e.g. JS10/PT5 or PT4. A protective circuit such as the 12V safe frequency input shown in section 3.4.14 is required. The 1k pullup can be installed internally.

Settings

Control Mode: Open loop frequency

Control Output: high or mid current output of your choice to match your wiring

Output Polarity: Normal

A warning lamp may be configured.

Load Monitor Input: JS10 (PT5) or PT4

Capture Polarity: Inverted

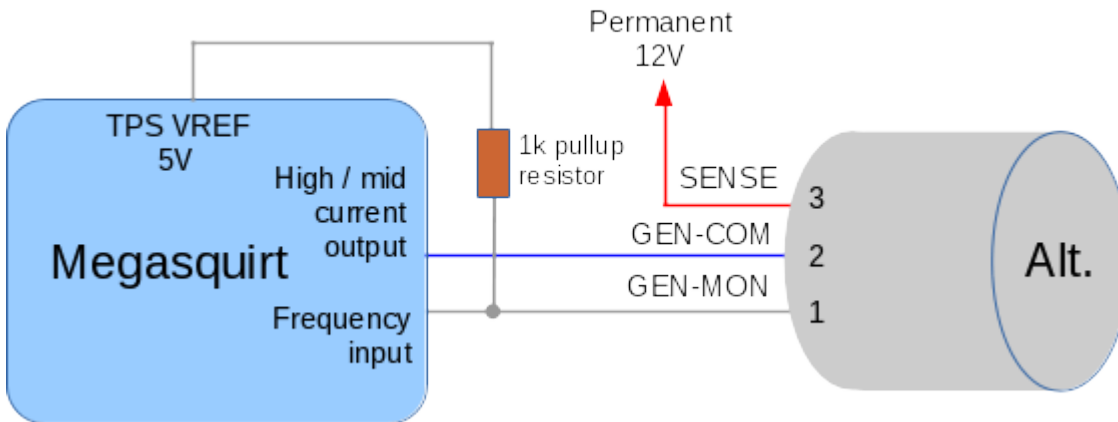

3.5.8.2 Chrysler Alternators

Most/all Chrysler/Jeep alternators use direct field control - the ECU gets direct control of the alternator "field" and is required to control it in a closed-loop manner to maintain system voltage. A switched, fused 12V supply is required and should be taken from the fuel-pump relay to ensure it is switched off when the engine is not running, around 5A is required.

If the software sees that the field is permanently switched on, but there is no charging happening, it presumes the alternator or drive belt has failed and turns off the current. The warning lamp will be illuminated.

There are two main types of alternator field connection : "isolated field" and "grounded field". The same settings are used for both types, but the external wiring is different.

Settings

Control Mode: High speed feedback field control

Control Output: a high current output of your choice to match your wiring

Output Polarity: Normal

A warning lamp may be configured.

1970-2006 : isolated field, low-side wiring

In this year range, both field terminals are available externally and a simple low-side driver circuit can be used. One side of the field is provided with fused, switched 12V and the other side is controller by the ECU.

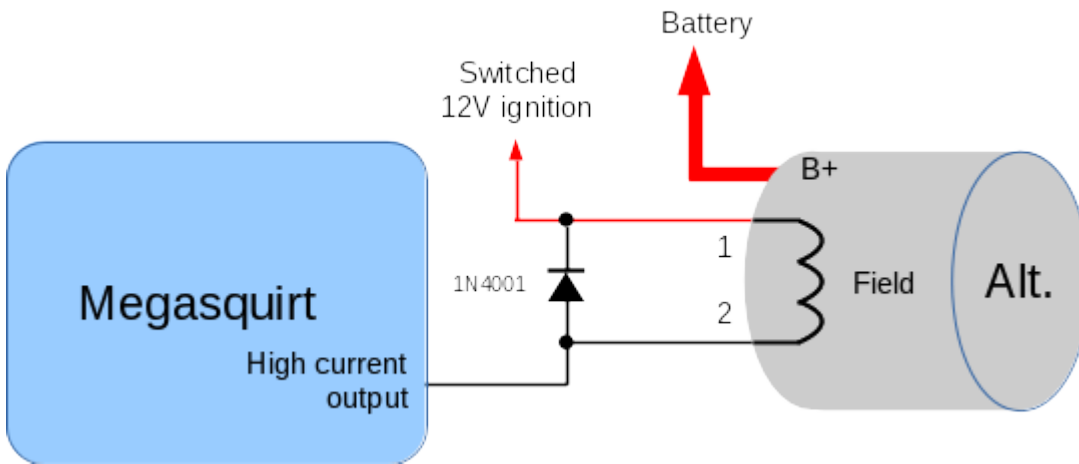

These alternators can optionally be wired as high-side with one side of the field externally grounded. See section 3.5.7 for sample circuit for high current output, the diode is best installed as shown above.

2007+ grounded field, high-side wiring

From around 2007 onwards, one end of the field is connected to ground internally and these require a high-side driver. The TIP125 shown must be mounted to a heatsink with a mica insulator.

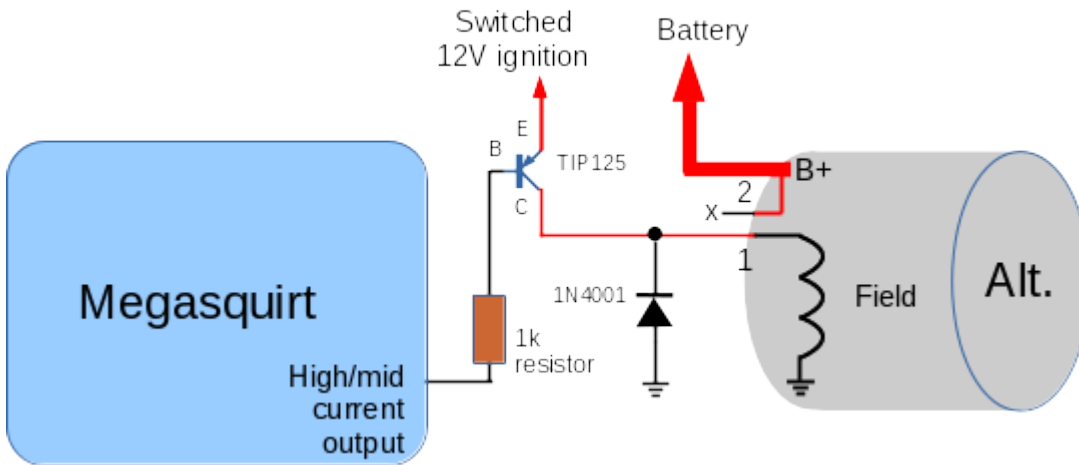

3.5.8.3 Miata alternators

1999 and up alternators use a form of ECU control. The ECU monitors system voltage and regulates the field at 20kHz.



P = Phase (untested)

D = Driver = 0-5V switching input to control the field

Settings

Control Mode: High speed feedback field control

Control Output: high or mid current output of your choice to match your wiring

Output Polarity: Inverted

A warning lamp may be configured.

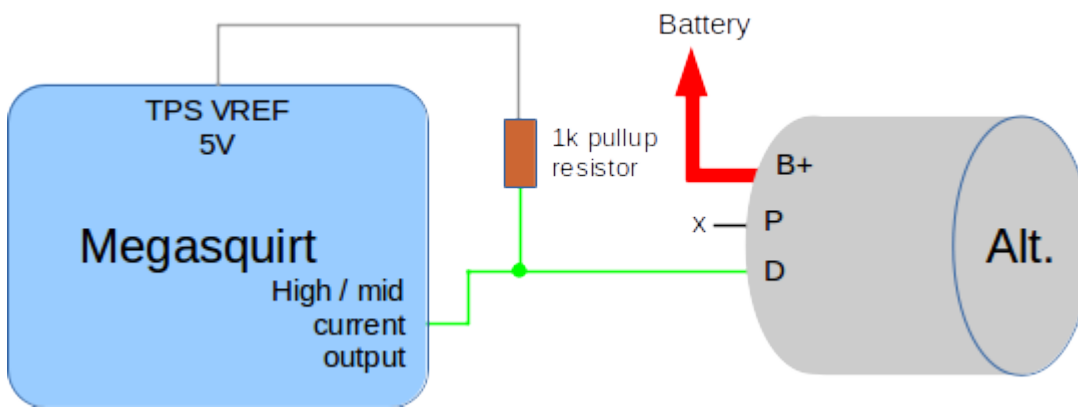

or with a 0-5V output:

Settings

Control Mode: High speed feedback field control

Control Output: 0-5V output of your choice to match your wiring

Output Polarity: Normal

A warning lamp may be configured.

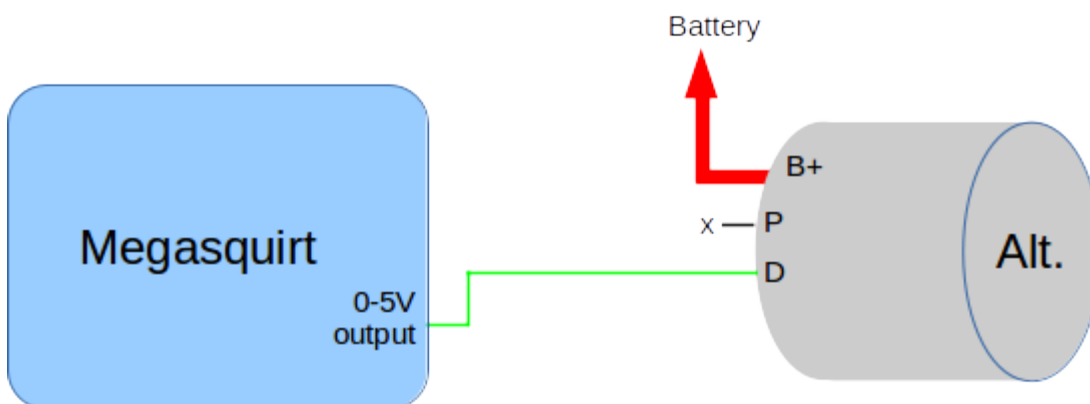

As a recap:

- when mid-current (relay) outputs are used, the "inverted" output setting is required.
- when digital 0-5V outputs are used, the "normal" output setting is required.

3.5.8.4 Chevrolet 4-wire alternators

CS series alternators (four pin) were used from the late 1990s to mid 2000s on V8 applications.

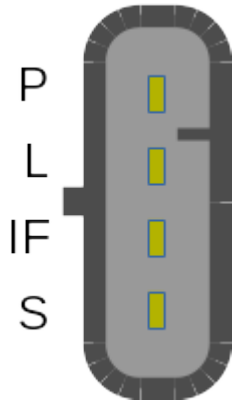

P = Phase.

Used as an engine speed output on some diesel engines.

L = Lamp.

Used as an input to enable the alternator and also as an output to indicate fault conditions.

I/F = Ignition or Field.

Ignition is a 12V feed to the alternator to enable it. (Untested.)

Field is a variable duty output to indicate the load on the alternator.

S = Sense.

Optionally used to monitor system voltage at a point away from the alternator, such as the fuse box.

Simple installation

The simplest installation is to use a traditional alternator lamp on the dash. Connect one side to the "L" terminal and the other side to switched ignition 12V.

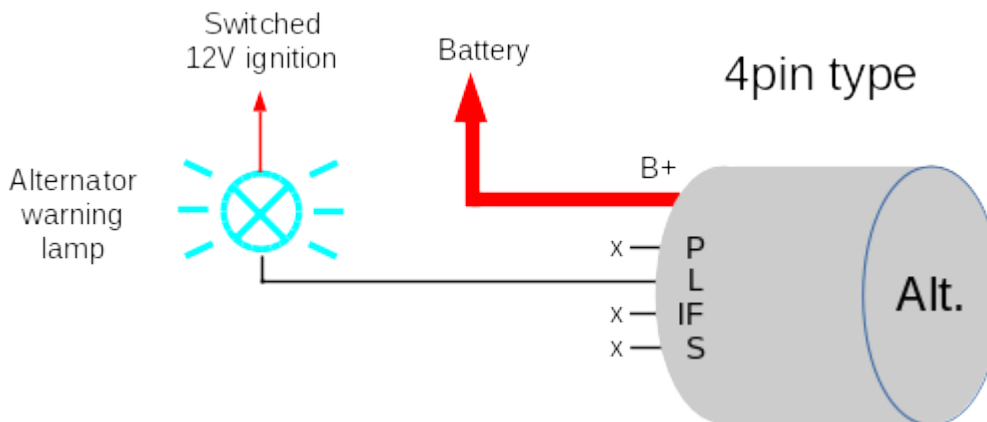

Basic ECU control

To take advantage of delayed alternator engagement, the "L" terminal needs to be connected to the ECU. A mid-current (relay) output is used with a 1K pullup resistor to 12V. The basic 'tacho' circuit in section 3.5.5 can be used. The purpose of the delay is to let the engine start and run for a few seconds before adding the load of the alternator which could cause a stall on a small low torque engine.

Settings

Control Mode: On/Off

Control Output: high or mid current output of your choice to match your wiring

Output Polarity: Inverted

A warning lamp may be configured.

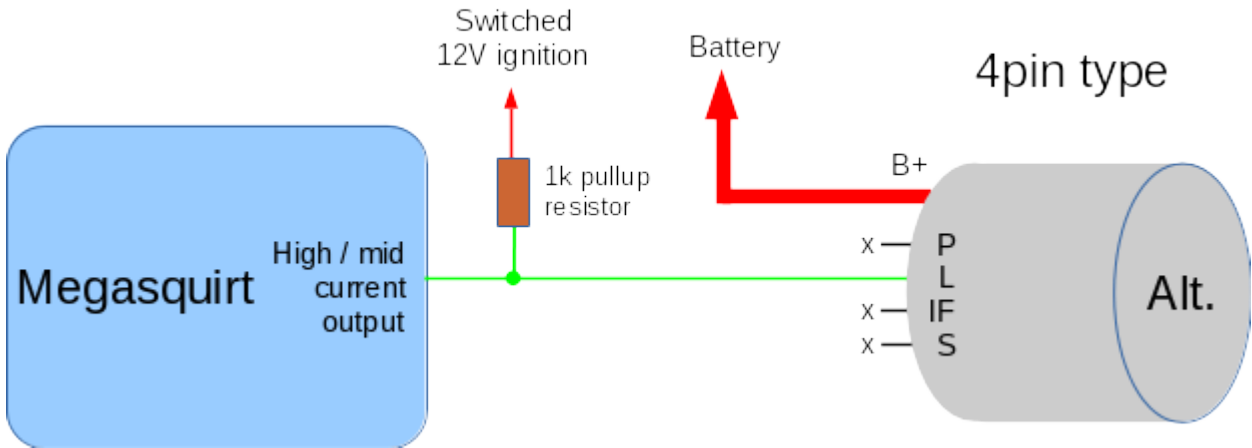

ECU control with load monitoring

There are reported to be two types of this alternator that use the "I/F" pin for different purposes. With the wiring unplugged, measure the resistance between "L" and "I/F". If a high resistance (over 1000ohms) is found, the "I/F" pin is used as a Field output. If a resistance around 400 ohms is found, the "I/F" pin is used as Ignition input. The "F" variant has been tested and gives a pulsed output on this pin that can optionally be used to monitor alternator load - connect to a digital frequency input (e.g. PT4.) The "I" variant has not been tested.

As in the previous section, to take advantage of delayed alternator engagement, the "L" terminal needs to be connected to the ECU. A mid-current (relay) output is used with a 1K pullup resistor to 12V. The basic 'tacho' circuit in section 3.5.5 can be used. The purpose of the delay is to let the engine start and run for a few seconds before adding the load of the alternator which could cause a stall on a small low torque engine.

The monitor input allows the load on the alternator to be observed. A frequency input is required e.g. JS10/PT5 or PT4. A protective circuit such as the 12V safe frequency input shown in section 3.4.14 is required.

Settings

Control Mode: On/Off

Control Output: high or mid current output of your choice to match your wiring

Output Polarity: Inverted

A warning lamp may be configured.

Load Monitor Input: JS10 (PT5) or PT4

Capture Polarity: Inverted

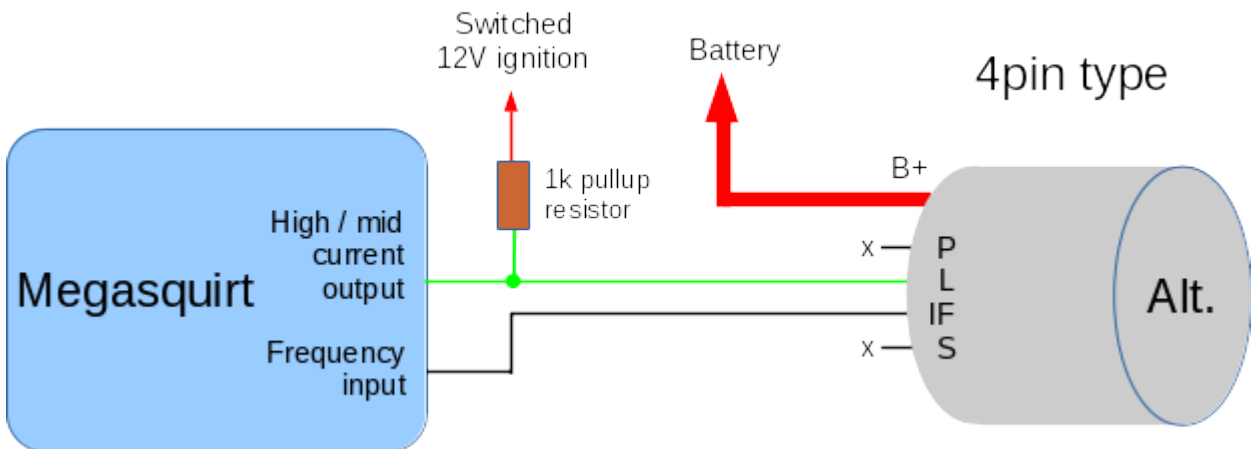

As a recap:

- when mid-current (relay) outputs are used, the "inverted" output setting is required.
- when digital 0-5V outputs are used, the "normal" output setting is required.

3.5.8.5 Chevrolet 2-wire alternators

RVC (remote voltage control) series alternators (two pin) have been used since the mid 2000s on many applications including Chevrolet/Daewoo vehicles.

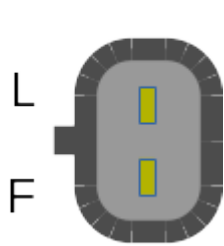

L = Lamp.

Used as an input to control the alternator voltage and also as an output to indicate fault conditions.

F = Field.

Field is a variable duty output to indicate the load on the alternator.

These alternators have true ECU control with a 128Hz 0-5V PWM signal to the "L" terminal. When the alternator is off or in fault conditions, the alternator pulls "L" to ground through a ~390R resistor.

The "F" terminal can be used to monitor alternator load.

GM uses a variable duty cycle set the alternator voltage.

Target Voltage	Duty
11.0V	10%
11.8V	26%
12.8V	42%
13.7V	58%
14.6V	74%
15.5V	90%

ECU voltage control

This requires that the required 0-5V PWM signal be generated and sent to the alternator "L" terminal. The diagram shows a mid current (relay) output (see section 3.5.6) with a pullup resistor to 5V.

Settings

Control Mode: Open-loop duty

Control Output: high or mid current output of your choice to match your wiring

Output Polarity: Inverted

Frequency: 128Hz

A warning lamp may be configured.

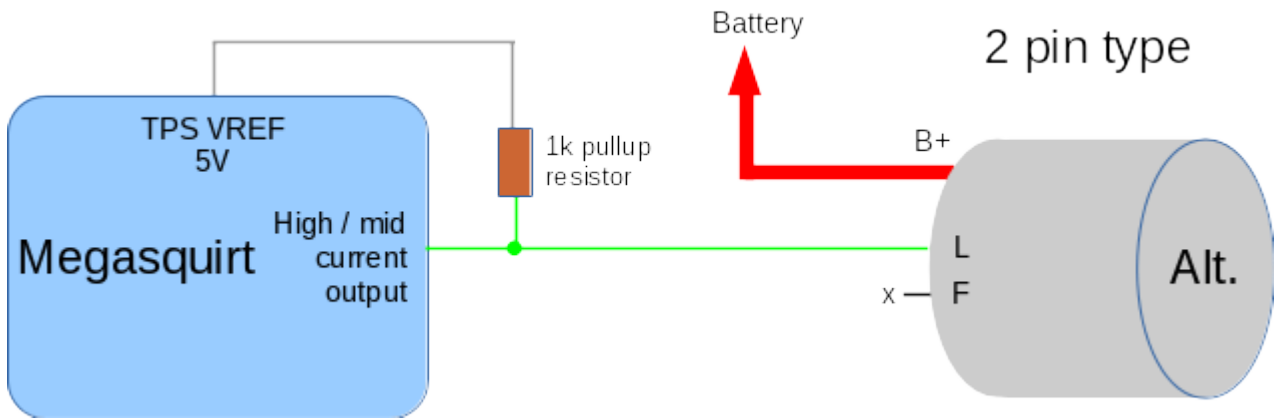

Alternatively, a direct 0-5V output may be used. Build the circuit in section 3.4.14, in this case the circuit is used as an output, the 1k resistor protects the processor when the alternator grounds the "L" terminal.

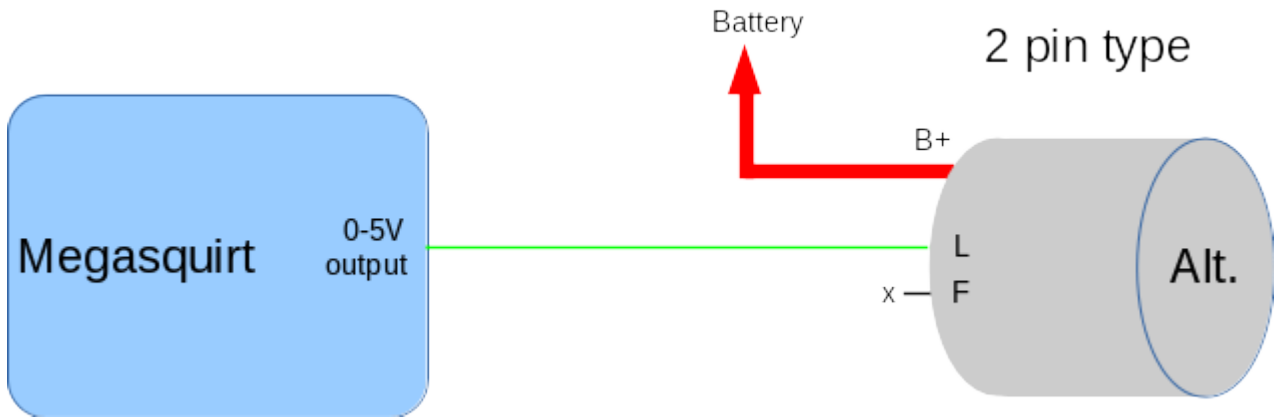

Settings

- Control Mode: Open-loop duty
- Control Output: high or mid current output of your choice to match your wiring
- Output Polarity: Normal
- Frequency: 128Hz
- A warning lamp may be configured.

ECU voltage control with load monitoring

This requires that the required 0-5V PWM signal be generated and sent to the alternator "L" terminal. The diagram shows a mid current (relay) output (see section 3.5.6) with a pullup resistor to 5V.

The monitor input allows the load on the alternator to be observed. A frequency input is required e.g. JS10/PT5 or PT4. A protective circuit such as the 12V safe frequency input shown in section 3.4.14 is required.

Settings

- Control Mode: Open-loop duty
- Control Output: high or mid current output of your choice to match your wiring
- Output Polarity: Inverted

Frequency: 128Hz

A warning lamp may be configured.

Load Monitor Input: JS10 (PT5) or PT4

Capture Polarity: Inverted

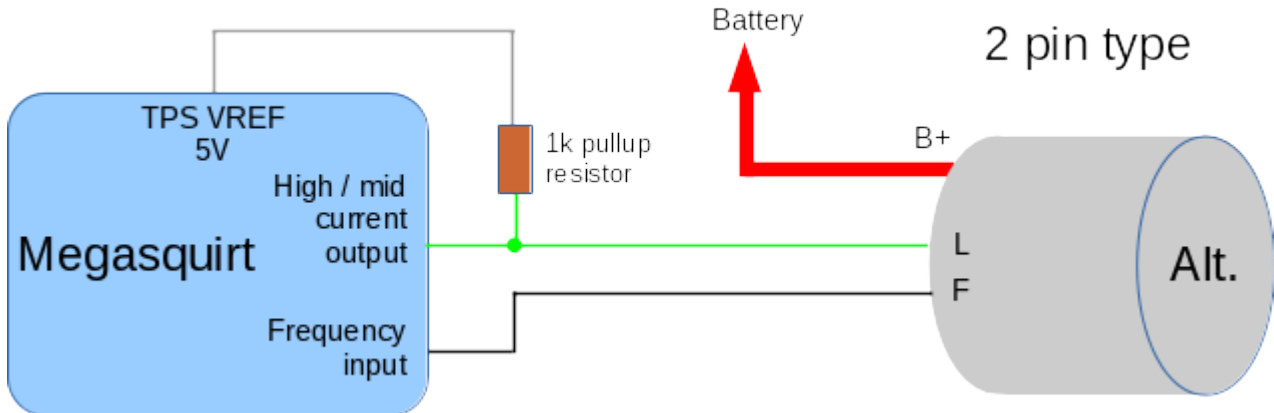

Alternatively, a direct 0-5V output may be used for the "L" terminal as described previously, in this case the "Normal" polarity would be required on the output.

As a recap:

- when mid-current (relay) outputs are used, the "inverted" output setting is required.
- when digital 0-5V outputs are used, the "normal" output setting is required.

3.5.8.6 Other computer controlled alternators

Other vehicle manufacturers may use their own specific control system, consult your vehicle workshop manual or supplier for information.

3.5.8.7 Other alternators

Most alternators are not computer controlled and should be connected as per the original wiring scheme.

Possible pin names:

- B+ = main battery connection.
- IG = ignition feed to alternator, usually permanent.
- L = dash indicator lamp connection.

3.6 Bench test wiring

Before installing on your engine, it can be useful to install the Megasquirt on the bench to become familiar with the tuning software.

3.6.1 Minimal connection

The bare minimum for testing is a fused 12V supply, ground and the serial connection to your tuning computer.

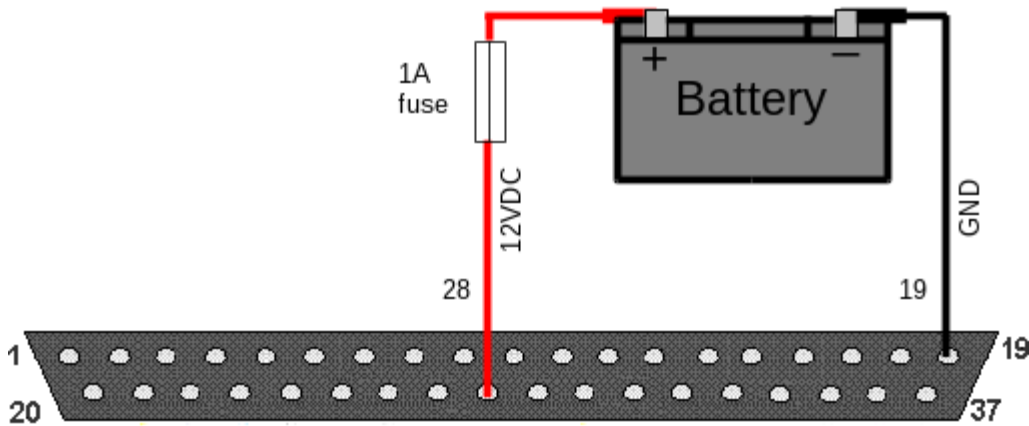

3.6.2 JimStim connection

For more extensive testing, the JimStim can be used. This has the mating DB37 connector to plug directly into your Megasquirt and can simulate many of the engine sensors. Make sure that the JimStim does not touch anything conductive as it is uninsulated.

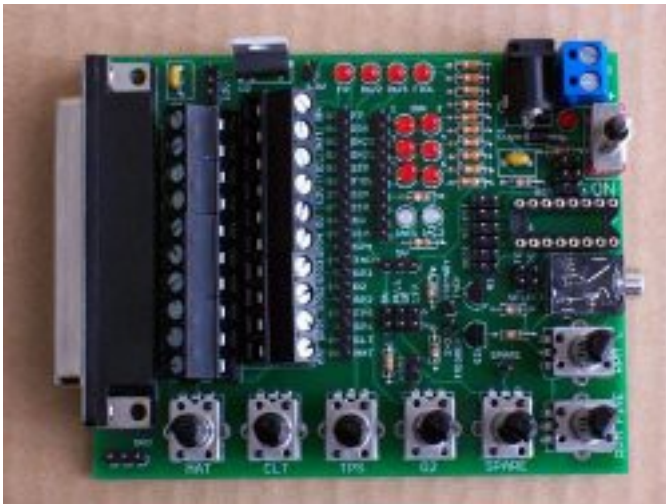

4: Fuel System



Fuel is extremely flammable and fuel systems run at high pressures. Be sure to have a fire extinguisher to hand in case of mishap and take appropriate caution when working on fuel systems.

4.1 Introduction

The fuel system install comprises electrical and plumbing work.

The Megasquirt mainboard has two injector outputs. These can supply up to 14A maximum each. Typically this allows up six injectors per channel. MS3/V3.57 supports both hi-z (14 ohm) and low-z (e.g. 2.5 ohm) injectors directly.

The MS3X connector has eight injector outputs. These can supply up to 5A maximum each. Typically one hi-z injector is used per channel. Injector resistors or an external peak&hold box are required for low-z injectors.

The following shows a typical EFI fuel system.

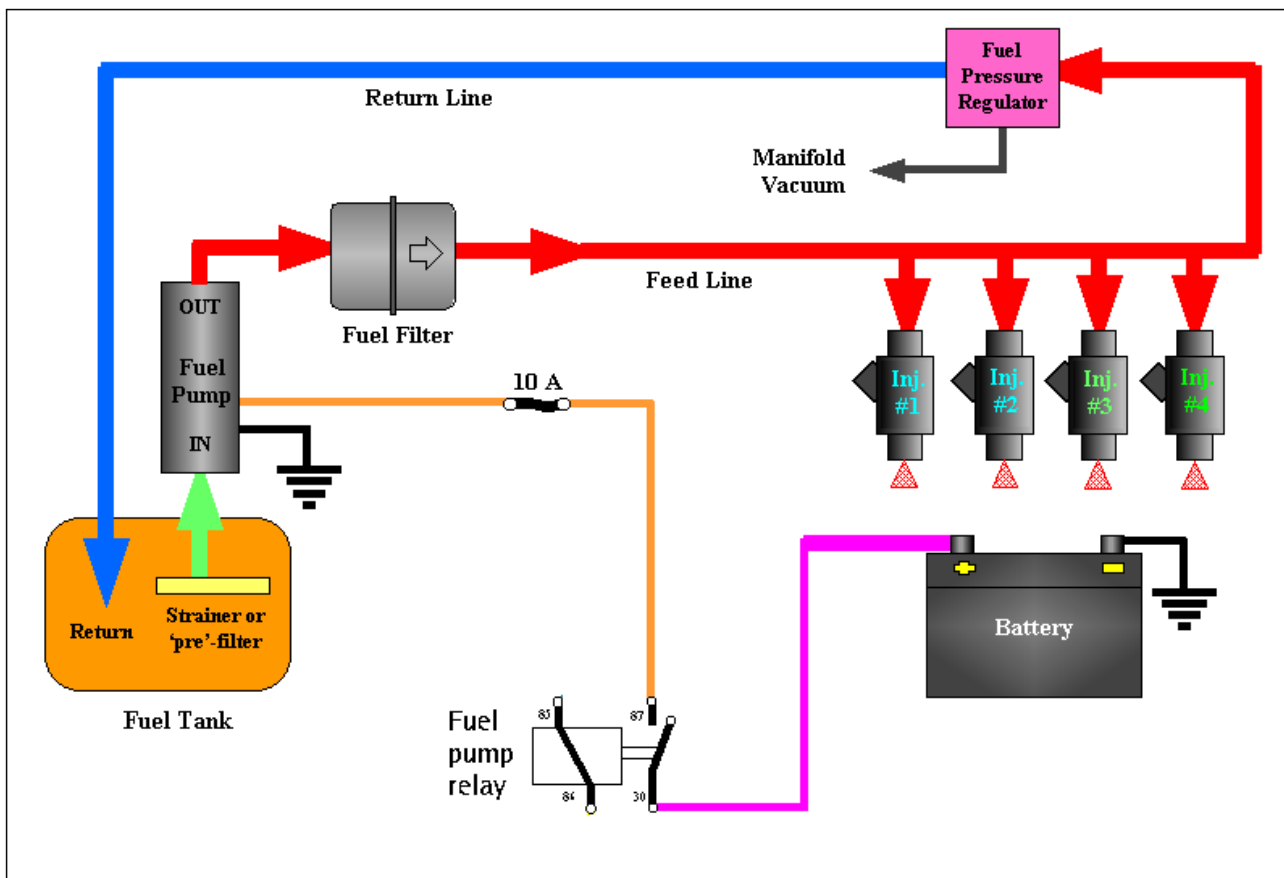

A high pressure pump is connected to the fuel tank and feeds fuel to the fuel rails(s) these provide fuel directly to the top of the injectors. The fuel rail(s) are connected to an intake manifold pressure referenced pressure regulator. The regulator maintains the rail pressure a set pressure above the intake under all conditions. Excess fuel is returned to the fuel tank through the return line.

Key elements

- Fuel pump
- Fuel hose/pipe and fittings

- Injectors
- Injector mounting
- Fuel rails
- Pressure regulator

4.1.1 Existing EFI Vehicle

Most vehicles with EFI already fitted are readily adaptable to use Megasquirt for control. Typically all of the fuel system components will be readily suitable.

However, if like many users you are increasing the power of your engine, you will need to consider whether your injectors are large enough and whether your fuel pump has adequate flow. In particular note that all fuel pumps flow less fuel as the pressure increases - so if you are boosting your engine you will be needing more fuel under the conditions when your pump can supply less!

Some recent engines use ECU controlled fuel pumps or dead-head systems with no regulator. The current MS3 code supports PWM fuel pump control for these systems. This will require using a solid state relay to drive the fuel pump and a fuel pressure sensor. Alternatively, you could convert to a conventional system with a vacuum referenced bypass regulator and return line.

4.1.2 Retro-fit EFI Vehicle

When installing EFI on a previously carburetted vehicle or a new build you have to source all the required fuel system components. There are many choices open to the retro-fit market. Be aware that a high horsepower install will often spend more on the fuel system than the ECU.

4.2 Single Fuel pump

You will need a high pressure pump with enough volume at your operating pressure to feed you engine under maximum load. Typical pressures needed in the neighborhood of ~45 psi for port fuel injection, ~10-20 psi for TBI injection. A port injection pump will work with TBI, but not vice-versa.

A standard EFI install uses a single high pressure pump connected as per the diagram in 4.1 above. Depending on your target power output, many OEM style pumps may be suitable. Surprisingly, some of the Bosch inline EFI pumps installed on 100hp cars are actually rated to 450hp fuel capacity. OEM style pumps are a usually a good choice as they are designed for trouble free operation for tens of thousands of miles.

OEMs sometimes place the pump inside the fuel tank. In an EFI retrofit it is generally easier to use an external fuel pump.

If an OEM style pump does not offer sufficient output, there are plenty of aftermarket high volume EFI pumps on the market.

4.3 Low pressure / high pressure - twin pump

For a basic retrofit, you may find that a low pressure/high pressure system is a simpler way to avoid tank modifications for the fuel pickup, although a fuel return to the tank is still required.

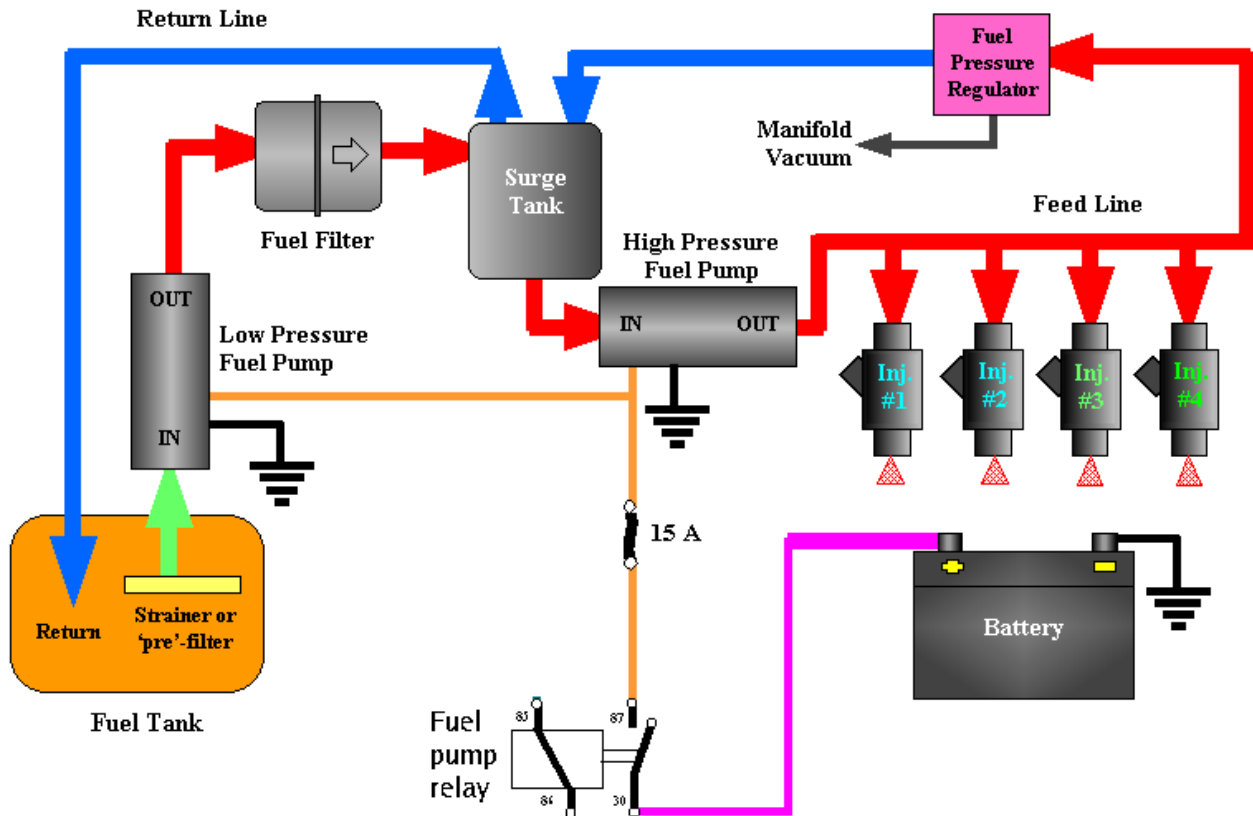

The low pressure side can be your existing electric fuel pump. You need to add the surge/swirl tank and high pressure side. For the tank return you may already have an return or evap canister connection or could connect into the filler neck, ensuring that fuel returns to the tank and cannot leak out of the vehicle. Surge/swirl tank can be purchased or you can make your own. Use thick wall TIGed aluminium or brazed steel. Ensure it is totally leak free.

4.4 Wiring the Fuel Pump

To activate the fuel pump, the Megasquirt provides a ground for the fuel pump relay circuit -see the main wiring diagram.

Ordinarily, at power on, the Megasquirt will run the fuel pump for 2 seconds, then when you start cranking the fuel pump is enabled again. If you stop cranking before the engine starts or you stall, the pump is turned off.

An inertial safety shut off switch is a good safety feature – it is used to kill power to the pump if there is significant impact to vehicle.

4.5 Fuel Line

Steel tubing or Cunifer (Bundy tubing) is recommended, but you MUST have short sections of flexible line in the feed and return lines between the engine and frame to allow for engine movement. The return line should have minimal restriction. For reference, GM systems typically have 3/8" feed lines and 5/16" return lines.

You may be able to use your original fuel line as a return line, plumbing a new 3/8" (10mm) line for fuel supply. You can run the return line into the tank, or reroute it to a fitting or nipple you install in the fuel tank filler neck/tube assembly (in which case you may be able to use the original pick-up for your supply line). If you run a new pick-up into the tank, it will need a filter.

You may have to fabricate fuel lines for your system. Tubing is available in steel, cunifer (bundy), stainless steel,

and aluminum for this purpose. Do not use plain copper and it can fatigue fail with dangerous leaks resulting. The size is generally given as the outside diameter of the tubing. Unless you have a very unusual combination (or very high horsepower, well over 500+), you should be able to use 3/8" tubing for both the supply and return lines.

Buy a good tubing bender (there are numerous styles in various price ranges) so that you don't kink or collapse the tubing while bending it.

Most fittings and adapters in the USA automotive aftermarket are based on a 37° sealing angle (SAE J514 37° -formerly known as JIC). These are also often referred to simply as AN fittings. Male and female 37° fittings will mate together for a leak-proof connection. Be aware that 45° fittings (commonly available in the USA) are not interchangeable with 37° fittings.

Abrasion (the rubbing of the hose against some other component) is the number one cause of hose failure. A leaking fuel hose can start a very dangerous fire in your car, so make sure hose assemblies are routed properly to reduce the chance of any abrasion damage. Use a support every 12 to 18 inches (30 to 45 cm) to secure the hose. For chafe protection, be sure to install a grommet at any point a hose passes through a panel or bulkhead.

Besides steel or aluminum tubing fuel line, you can also use one of the steel or nylon braided hoses from various suppliers. Generally these use the same AN 'dash' sizing system, and can use appropriate fittings to connect to 37° flare, NPT thread, or other systems.

Note that if you are using a factory fuel rail, you may be able to find an aftermarket adapter to mate your OEM fuel fitting to an AN hose.

IMPORTANT: Keep the fuel lines out of passenger compartment and routed safely away from moving or hot parts to avoid damage/excessive heat. For flexible rubber hose use the SAE 30R9 EFI hose which is rated at 250 psi. EFI hose clamps are also recommended rather than gear clamps. Check with someone who knows if you are not sure about your installation. Nobody needs a 50 psi gasoline fed fire to ruin their day!

4.6 Fuel filter

Use a fuel injection fuel filter rated for the pressure at which your system operates. **DO NOT** use a universal carburettor filter - the higher pressure of fuel injection systems may cause it to burst! Position the filter downstream of the pump so that a clogged fuel filter will not over heat the fuel-cooled pump. However, if you fuel pickup does not include a strainer, it is wise to install a coarser filter ahead of the pump. When using original old steel fuel tanks, pieces of rust can dislodge and jam the fuel pump.

4.7 Fuel Pressure Regulator

The vacuum referenced fuel pressure regulator is essential. It provides constant pressure differential between fuel at injector nozzle and manifold air pressure [port EFI] or atmospheric pressure [TBI]. This makes the injected fuel quantity solely a function of the injector open time. Without the vacuum/boost reference connection you would need an excessively small pulsewidth under cruise/idle and an enlarged pulsewidth under wide open throttle or boost. Make sure the regulator is connected to a full vacuum source, not ported-vacuum. Check it has vacuum with the engine idling and the throttle shut.

If you have an adjustable fuel pressure regulator (FPR), set the pressure with the fuel pump running, but the engine not running - that's your base fuel pressure (it is referenced to atmospheric pressure).

The regulator is typically at the far end of the fuel rail (after the injectors) which recirculates all of the fuel, keeping it cool and free from air pockets. However, it can be installed anywhere after the fuel pump, but you may experience fuel heating and air pockets.

If you are using an aftermarket fuel pressure regulator, it is a good idea to also install a pressure gauge, since most of these are adjustable. For TBI, use a 0-30 psi gauge. For port injection use a 0-60 psi or 0-100 psi gauge. Most of these gauges will mount directly on a fuel fitting using a 1/8" NPT thread.

4.8 Injector installation

Many "high performance" vendors offer ready made EFI intake manifolds for engines that did not originally come fitted with EFI. Or you can choose to modify your existing intake by welding, glueing or screwing in injector bungs. Many aftermarket vendors offer suitable injector bungs.

4.9 Fuel Rails

Most injector systems will use one or more fuel rails. These serve two functions: they supply fuel to a multiple number of injectors (4 on a 4 cylinder, for example), and they physically locate the tops of the injectors. Most OEM rails can be made to work with standard engine configurations, but if you are doing a custom conversion you may have to fabricate fuel rails. Many place supply blank aluminum fuel rail extrusions in whatever length you need.



4.10 Fuel Injectors



4.10.1 Injector Size

It is important that your injectors are correctly sized for your engine size and power requirements. Too small and you will run out of fuel at high power and rpms, with likely engine damage from going lean. Too large and you will encounter tuning difficulties for idle and cruise conditions.

You can use the following chart to select injectors based on the total horsepower of your engine and the total number of injectors:

Injectors Rating Required in cc/min (lbs/hr)

Horsepower	Number of Injectors					
	1	2	4	5	6	8
100	620 (59)	305 (29)	158 (15)	126 (12)	105 (10)	-
150	924 (88)	462 (44)	231 (22)	189 (18)	158 (15)	116 (11)
200	-	620 (59)	305 (29)	252 (24)	210 (20)	158 (15)
250	-	777 (74)	389 (37)	305 (29)	263 (25)	189 (18)
300	-	924 (88)	462 (44)	368 (35)	305 (29)	231 (22)
350	-	-	524 (51)	431 (41)	357 (34)	273 (26)
400	-	-	620 (59)	494 (47)	410 (39)	305 (29)
500	-	-	777 (74)	620 (59)	515 (49)	389 (37)
600	-	-	924 (88)	746 (71)	620 (59)	462 (44)
800	-	-	1239 (118)	987 (94)	819 (78)	620 (59)
1000	-	-	1544 (147)	1240 (118)	1030 (98)	777 (74)
1500	-	-	-	-	1575 (150)	1187 (113)
2000	-	-	-	-	-	1554 (148)

Based on 0.50 BSFC and 85% duty cycle
 Turbo/supercharged engines should add 10% to listed minimum injector size

Injectors are usually rated in either lbs/hour or cc/min. The accepted conversion factor between these depends somewhat on fuel density, which changes with formulation (i.e., by season), but the generally used conversion for gasoline is:

1 lb/hr ~ 10.5 cc/min

Another way to select injectors is to take them from an engine that makes nearly the same power as your engine will [assuming the same number of injectors].

If your regulator is adjustable (many aftermarket ones are), you can also adjust the fuel pressure to achieve different flow rates. Changing the fuel pressure doesn't affect the flow rate as much as you might assume, since it is based on the square root of the pressure ratio. The formula is:

$$\text{new flow rate} = \text{old flow rate} \times \sqrt{(\text{new pressure} \div \text{old pressure})}$$

So for example, if you had 30 lb/hr injectors rated at 43.5 psi, and you went to 50 psi, you would get:

$$\text{flow rate} = 30 * \sqrt{(50/43.5)} = 32 \text{ lb/hr}$$

Do not run more than 70 psi fuel pressure, or the injectors may not open/close properly.

However, do not install injectors with a much larger flow capacity than you need. Very large injectors will create idle pulse width issues that will make tuning very difficult.

4.10.2 Injector Impedance and batch-fire wiring

Injectors can typically be categorized as either high impedance (hi-z, high-ohm, saturated) or low impedance (low-z, low-ohm, peak and hold.) It is important to know which type your injectors are. Both types can be used with Megasquirt although high impedance tend to be easier to use.

New injectors will specify which type they are or list the ohms. If you are unsure, measure them with your meter on the ohms setting.

- High impedance injectors are typically 12-16 Ohms.
- Low impedance injectors are often 2.5 Ohms or less.

Do not simply connect and hope.

4.10.2.1 High impedance injectors (12-16 Ohms)

These injectors can be directly connected to the Megasquirt. No need for injector resistors and Injector PWM should be turned off.

Up to 6 injectors per channel may be connected.

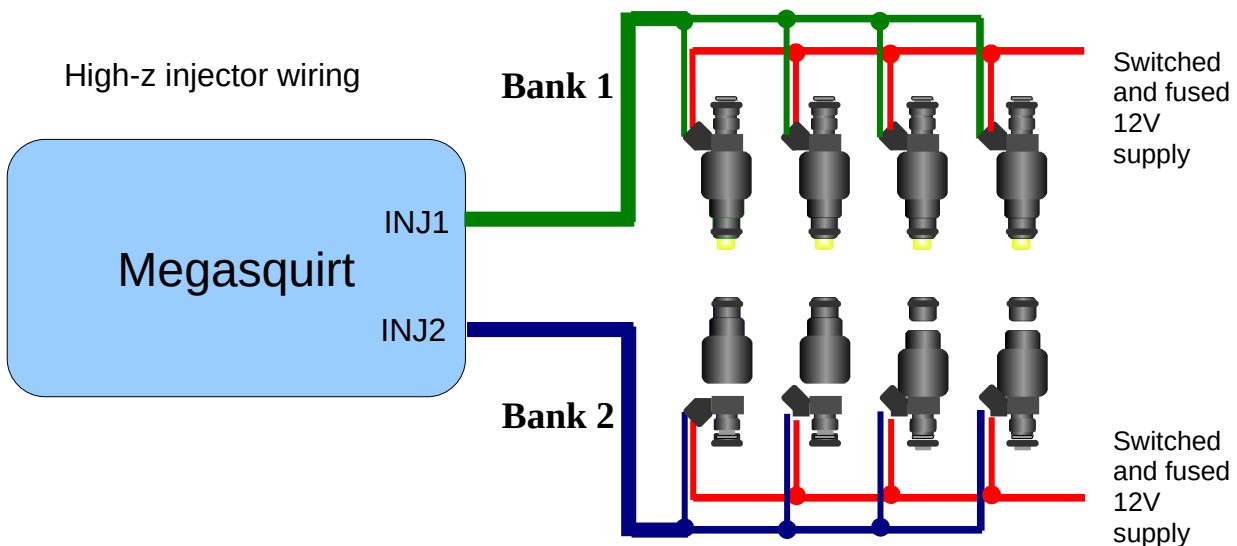

4.10.2.2 Low impedance injectors (less than 3 Ohms)

These injectors can be used, with a few connection options.

- Injector PWM
- Injector resistors
- External peak-and-hold adapter

4.10.2.3 Low impedance injectors - Injector PWM

Injector PWM is built into the MS3/V3.57 and allows direct connection of low-z injectors. The PWM mode is effectively "peak and hold" controlled by software. At each injection event, full power is applied to the injector until it opens, then the output drops back to a pulsed output to hold the injector open.

During cranking full current is applied to the injectors.

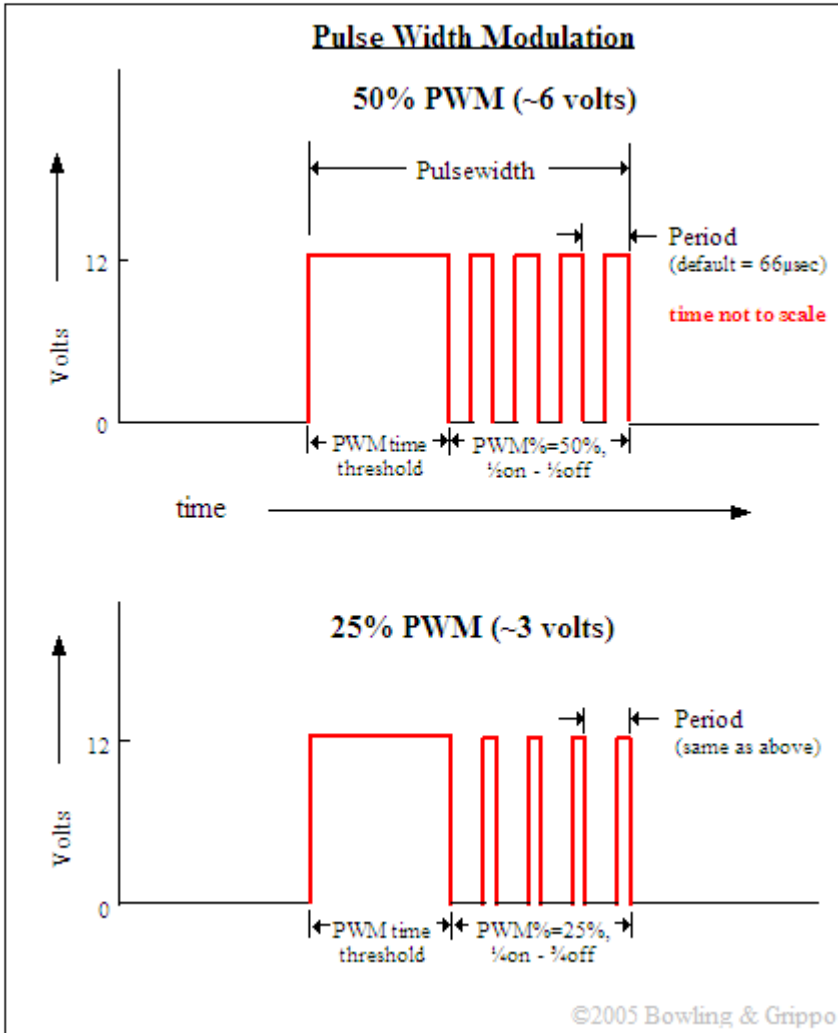

30% PWM duty is recommended with MS3/V3.57.

Be sure that you have sufficient power grounds from your Megasquirt to the engine.

A small number of installs have reported interference from the PWMing of injectors. Re-routing the flyback current can help. (See Appendix.)

4.10.2.4 Low impedance injectors - Injector Resistors

This method has been used by many OEMs as a simple approach to driving low-z injectors. The installer has the option of installing a power resistor (typically with a 20 to 25 watt rating) in series with each injector (in effect converting them to high impedance.)

The series resistors will slow down the opening of the injector slightly, so it is suggested that the resistance of the resistors be kept to a minimum but staying within the 14A limit of each injector channel. One resistor must be used for each injector - do not try to share resistors.

For typical 2.5ohm low impedance injectors, the following resistances can be used

Number of injectors per channel	Resistor value
1	3.3 ohm
2	4.7 ohm
4	10 ohms

The resistors should be mounted to a suitable heatsink (e.g. a thick piece of aluminium plate) as they will get hot in operation.

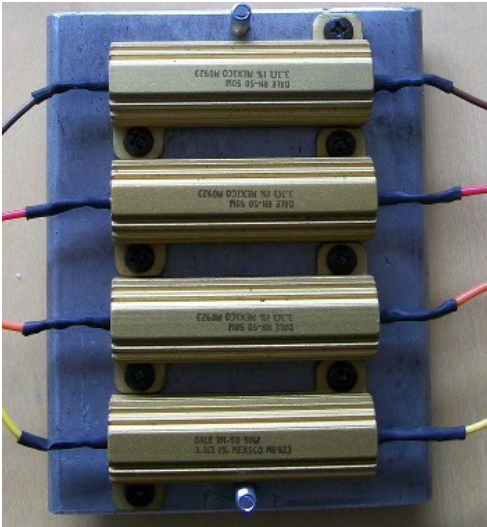

Low-z injector wiring with resistor

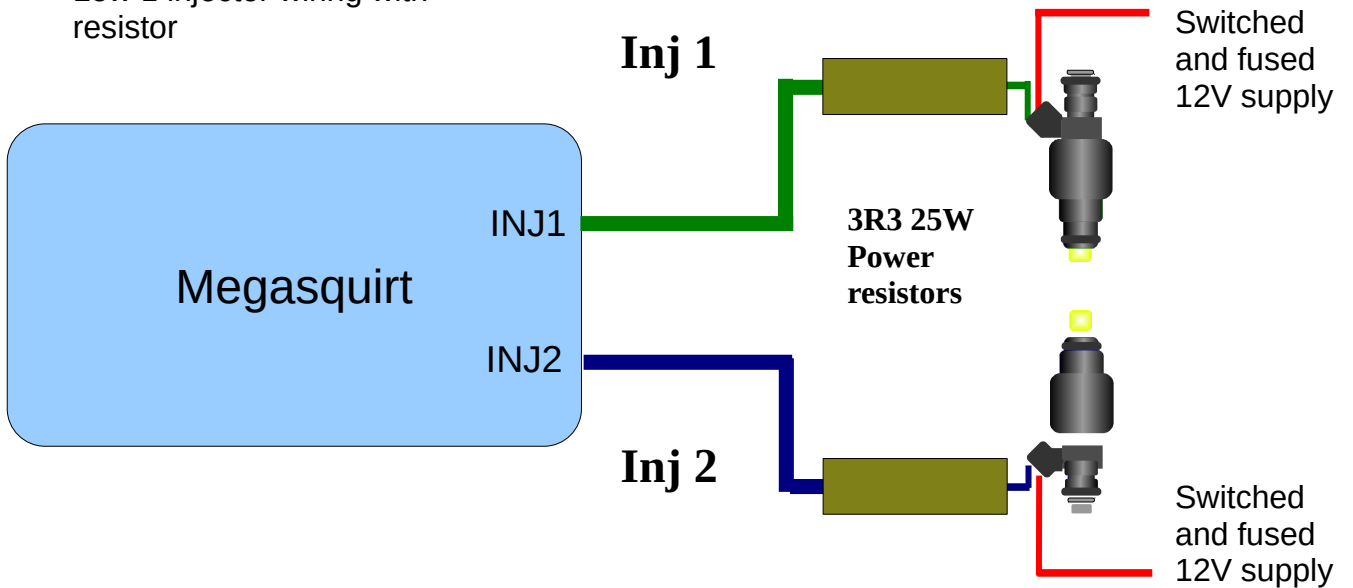
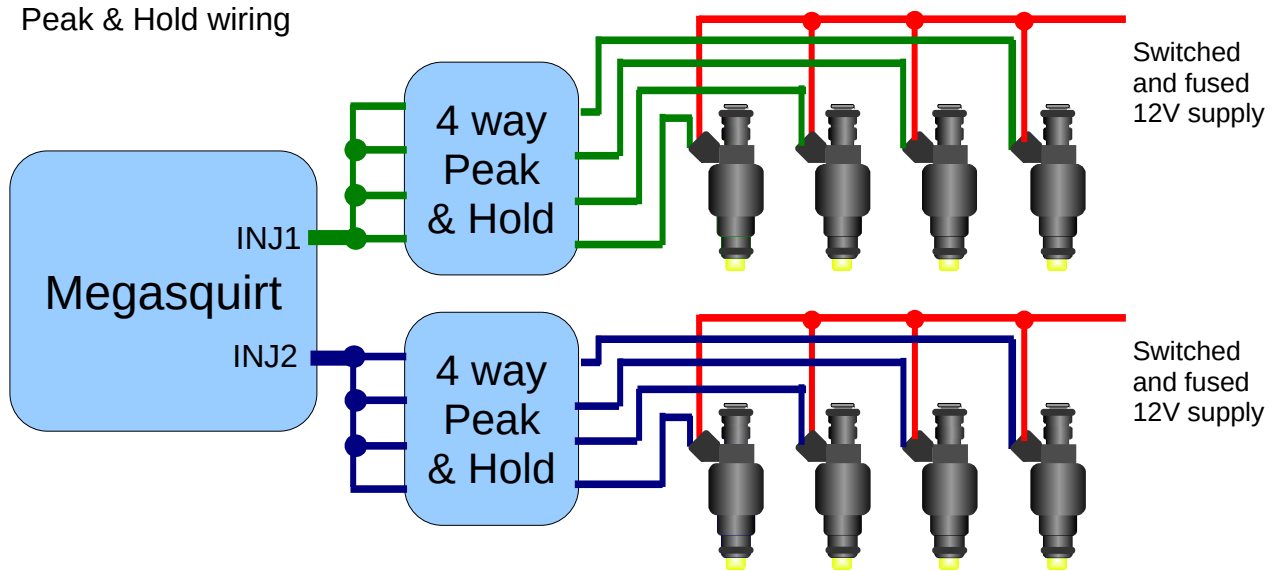

Diagram showing one injector per channel and 3.3 ohm series resistors.

4.10.2.5 Low impedance injectors - Peak and hold

Aftermarket peak and hold controllers are available, these take the low-side injector output from the Megasquirt and provide the required peak and hold drive for the injectors. Typically this is a peak to 4A and then a hold at 1A.

Refer to supplier's documentation for exact wiring - the following diagram is representative only.



4.10.3 Staged injection

Staged injection is a method that allows for two sets of injectors to give a better dynamic range of fueling - more precise control at idle, but still flowing enough fuel at full load. Typically, at low load, idle or cruise only the smaller primary injectors are in operation. At higher fuel demands, the secondary injectors are enabled.

When using "Staged Injection" the primary injectors are connected to INJ 1 and the secondary injectors are connected to INJ 2.

See the TunerStudio reference manual for configuration details.

4.10.4 Sequential injection

The MS3 was designed to run sequential fuel and spark. The sequential output signals are provided on the J1 and JP2 headers. These are low-voltage signals designed to feed the MS3X card.

In the absence of the MS3X card, the competent DIYer may be able to wire up an interface card instead. The details are beyond the scope of this manual.

Two complementary pieces of hardware that may be of use come from JBperf.com

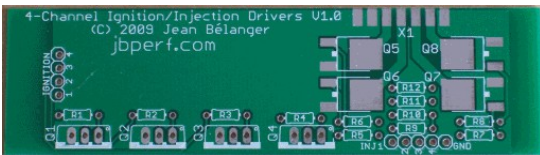

4 way high-z driver board

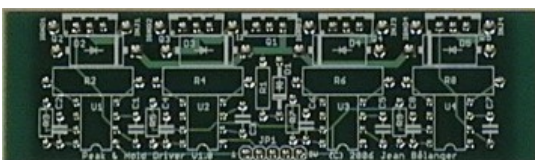

4 way peak&hold low-z driver board

5: Ignition System - fundamentals

The ignition system comprises both the crank and cam tach inputs and the ignition outputs to drive coils. There are many different combinations possible, this chapter will describe some of the possibilities.

Note: A tach input is required on ALL installs including fuel-only.

5.1 Safety Notes



Ignition systems produce dangerous voltages in excess of 30,000V. Take care to avoid shock.

5.2 Crank and Cam tach inputs

The tach input is one of the most important signals going into the Megasquirt and correct system operation is not possible until the tach input is correctly installed and configured. **Until the Megasquirt reads the correct RPM, nothing else will work.**

Even if you are starting with fuel injection only (not controlling ignition) you must still provide the Megasquirt with a tach input - see coil negative triggering in section 5.2.1

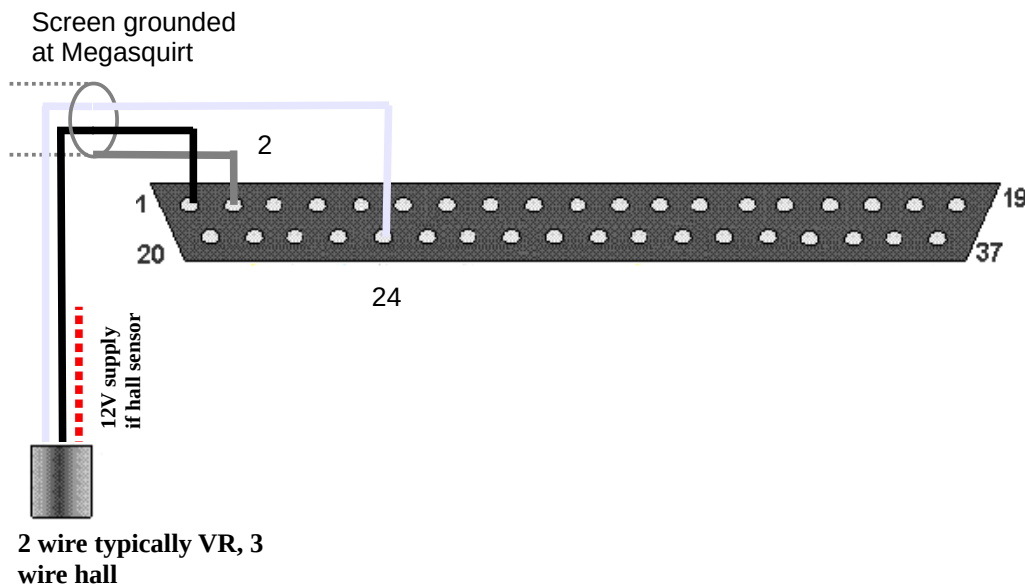

The MS3/V3.0 as standard has a single tach input. You must customize the board internally to select whether this input connects to the opto-isolator input for coil-negative triggering, or to the 'universal' tach input circuit.

Installs requiring a second tach input (cam sensor or part of a CAS) will require additional internal modifications. See section 5.2.14.

There are many different options for tach input and this is probably one of the largest areas of difficulty with any after-market EFI install. The firmware contains software decoders to suit many stock installs using original sensors. If your engine is supported, then this is the recommended approach.

Two key pieces of information you need to know are:

- Sensor type(s)
- Toothed wheel pattern

The sensor types fall into a few basic families of sensors and the right way to use the sensor depends more on

the type rather than the particular vehicle or manufacturer. There are also a few "special" systems in use from the eighties that combine a sensor input with an ignition driver output in one module. These will be discussed later - Ford TFI, Ford EDIS, GM HEI, GM DIS.

If you are considering an after-market, non-OEM sensor you must ENSURE that it has a suitable temperature rating. Typically engines run at around 100°C/212°F so a minimum of 105°C rating is required, 125°C desired. Do not consider using 85°C rated parts around the engine as they will degrade and cause you trouble. Be aware of heat radiated from exhaust components - these can overheat sensors and cause failure.

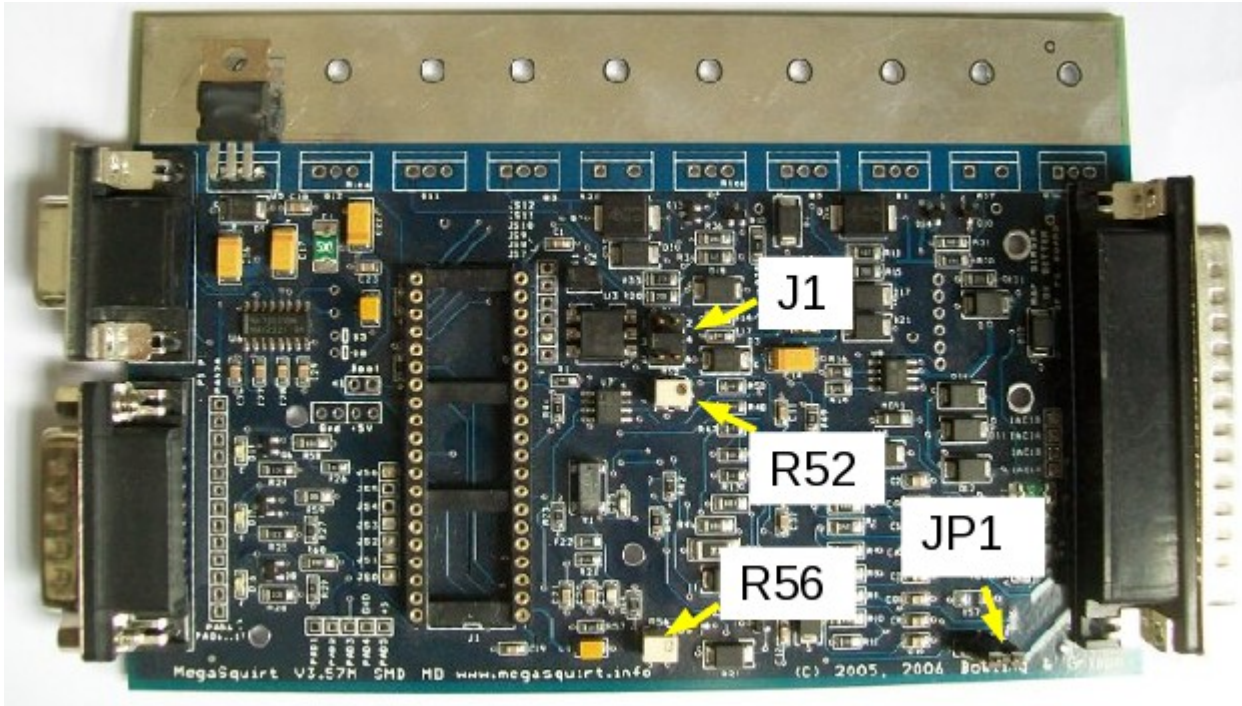

5.2.1 Coil Negative Input

For fuel-only installs it is possible to obtain a tach in trigger from the negative terminal of a single coil.

Coil negative (not CDI)



Opto-isolator (for coil negative fuel-only triggering):

- Find JP1 in the bottom right of the board. Place a jumper across positions 2 and 3
- Find J1 in the middle of the board. Place a jumper across positions 1 and 2
- Place a jumper from XG1 to XG2 (just to the left of J1 above U3.) In exceptionally noisy situations it might be required to remove that jumper and instead runs XG1 out through a spare connection on the DB37 and through

the wiring harness direct to the engine.

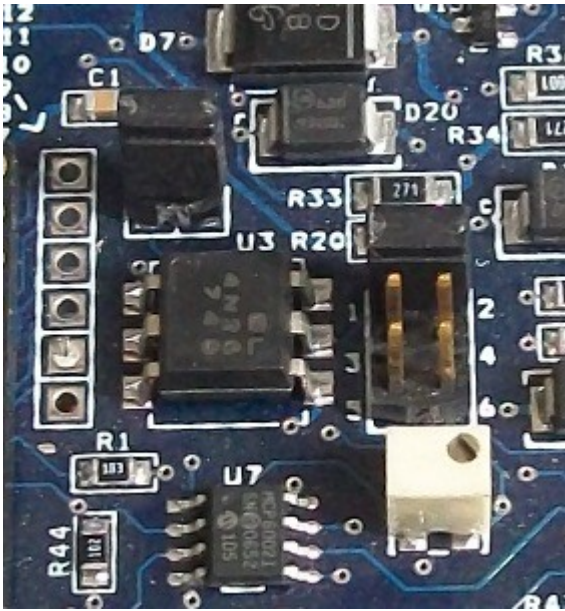

See also section 6.1 for fuel only setup.

5.2.2 VR (magnetic) sensor input



The VR sensor is a very commonly used sensor. Usually it is seen as a two wire sensor although some manufacturers install a screen on the cable, so yours may have three wires. In CAS (crank angle sensor) units a multiplug may be used to combine multiple sensors. The sensor itself generates an AC voltage when a piece of steel (the trigger) moves past it. Non-ferrous trigger wheels will not work. The voltage varies from less than a volt during cranking to tens of volts at higher revs.

Typically it is suggested that the magnetic tip of the sensor is around the same size as the teeth on the wheel.

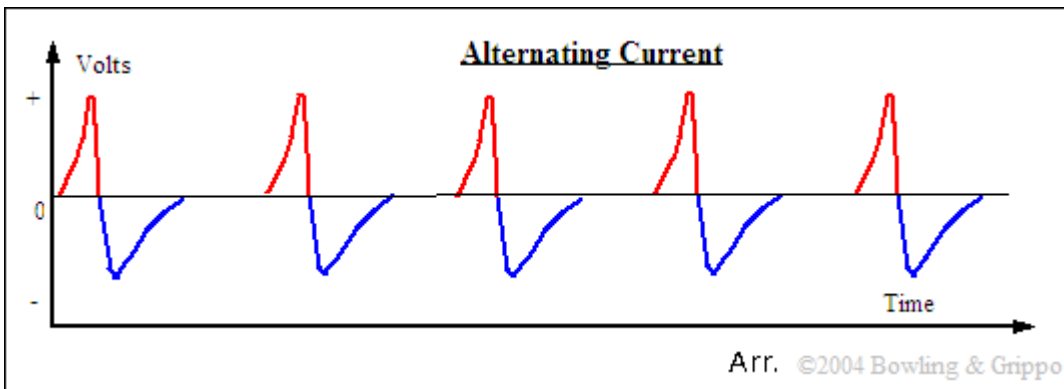

In order to use a VR sensor a "conditioner" circuit is required to convert the AC voltage into a DC square wave

signal while retaining the timing information. The Megasquirt has this conditioner built in. The two signal wires from the VR sensor are connected to Tach-in and GND at the Megasquirt. Ideally use a screened twisted pair cable and connect the screen to sensor ground at the Megasquirt end only.

VR sensor

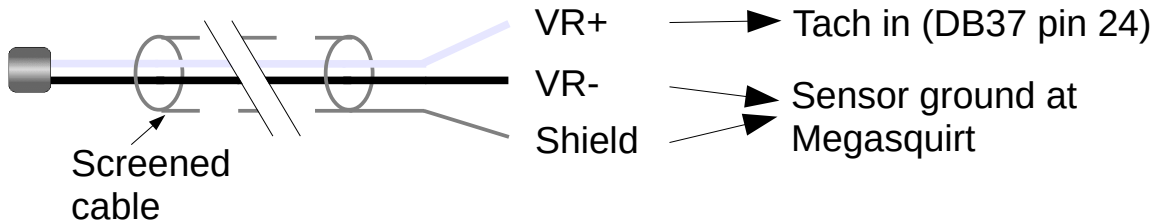

The mainboard needs to be set as follows:

VR Input for VR (magnetic) sensor

- Find JP1 in the bottom right of the board. Place a jumper across positions 1 and 2
- Find J1 in the middle of the board. Place a jumper across positions 3 and 4
- With a small screwdriver, turn the pots, R52 and R56, 7 turns anticlockwise (sometimes you may feel a "click" when the end position is reached, they can't be damaged by turning too far.) This sets them up for most VR sensors.

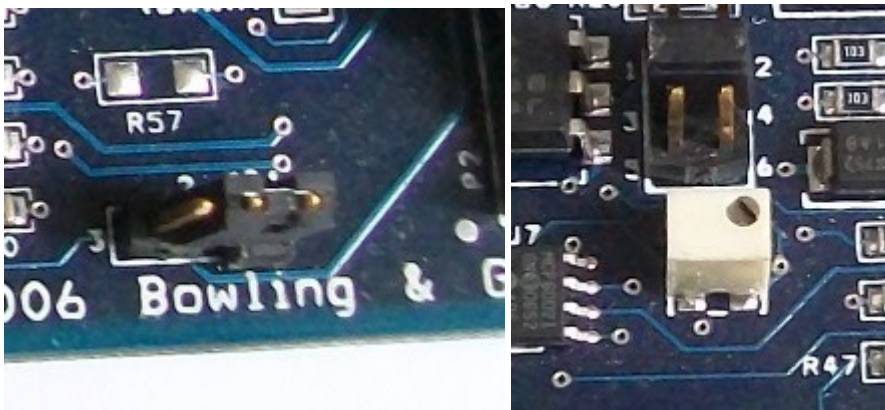

Optionally, when adjusting R56, you can measure the voltage at the "top" of R54. You'll need the board powered up. Set your meter to volts, and connect the +ve probe to the top of R54 and the -ve probe to ground. Adjust R56 to get the lowest voltage on your meter.

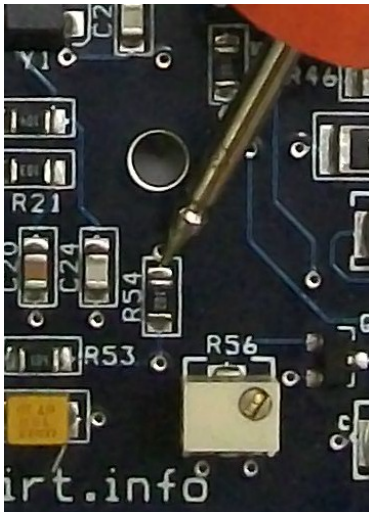

Some installs may find it necessary to install a resistor inline with the VR+ wire to reduce the signal voltage at higher RPMs. Typically a 10k 1/4W resistor is sufficient.

5.2.3 Hall sensor input

The Hall sensor is another commonly used category of sensor. These are almost exclusively a three wire sensor. In CAS (crank angle sensor) units a multi-plug may be used to combine multiple sensors. The sensor itself acts like a switch to ground in the presence of a magnetic field. Hall sensors are commonly seen in distributors where vanes or shutters mask off the magnetic field causing the sensor to rapidly switch on or off at the edge of the vane. Another way that a hall sensor can be used is with a "flying magnet" installed on a rotating part of the engine (crank, cam sprocket etc.). As the magnet passes the hall sensor, the output switches to ground.

The most common OEM arrangement for a hall sensor is within a distributor. The vanes in the distributor rotate and block or unblock a magnet.

With no vane between the magnet and sensor - the output is grounded.

With a vane between the magnet and sensor - the output is inactive.

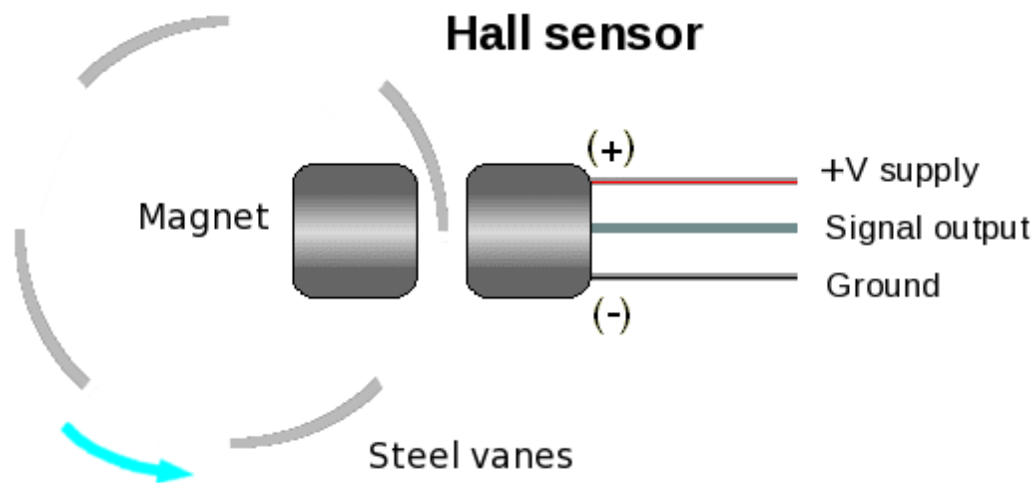

Above: diagrammatic representation.

Below: OEM dizzy modified to make single-tooth cam trigger.



There are two main categories of hall sensor

- open-collector (needs a pull-up resistor)
- built-in pull-up resistor (covered in section 5.2.4)

How to tell the difference?

Wire up the power and ground connections to the hall sensor and connect a volt meter between the signal wire and ground. Now rotate the vane assembly (turn the engine) or position the sensor by some steel and away from steel and see what voltages you get. If you get 0V in one state and close to 5V (or 12V) in the other state, then your sensor almost certainly has a built in pull-up resistor. If you get 0V in one state and a fraction of a volt in the other state, then your sensor almost certainly does not have a built in pull-up resistor and will need one installing.

The following diagrams show some of the principles involved.

Hall sensor (open collector)

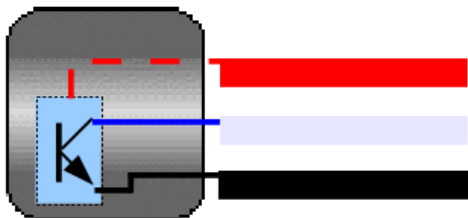

Equivalent circuit

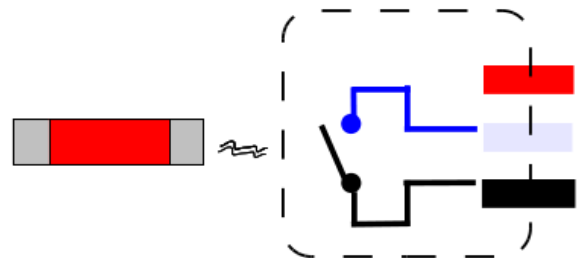

Sensor gives a ground in presence of a magnet.
Gives floating (no output) with no magnet.

Pullup resistor **REQUIRED**.
(Either in loom or inside ECU.)

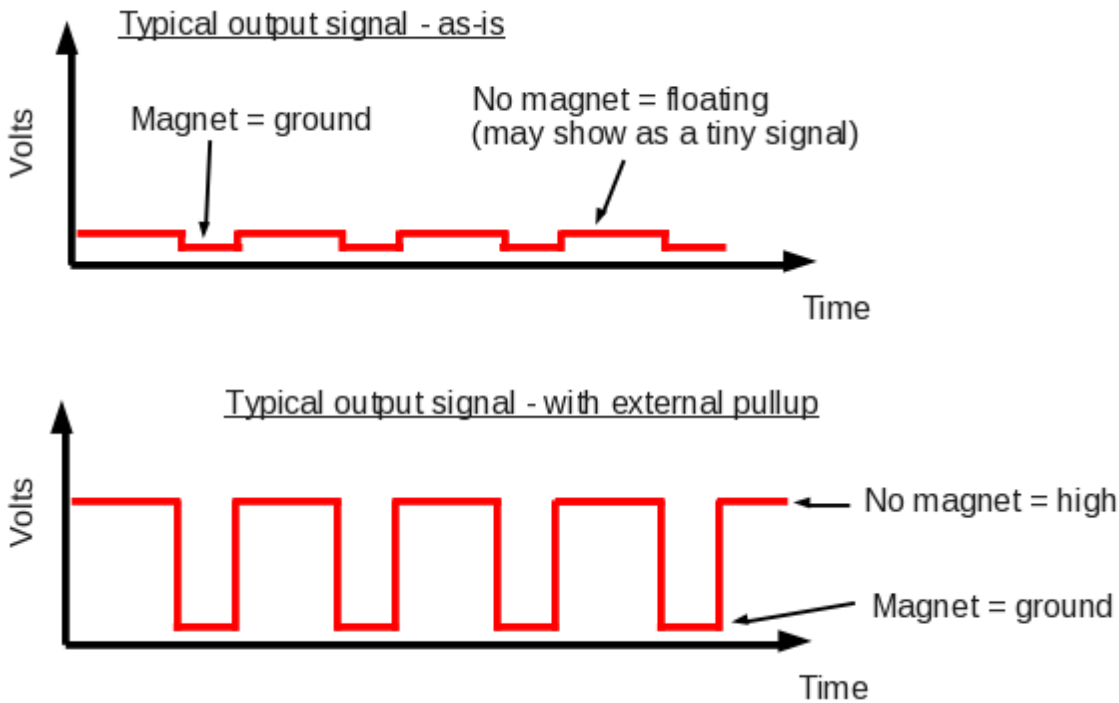

The hall sensor requires a supply voltage which is usually 12V from a fused 12V supply or 5V from the TPSREF output of the Megasquirt. The sensor is then grounded at the Megasquirt sensor ground and the signal wire connects to the Tach input. A pull-up resistor is required in the wiring harness or inside the Megasquirt.

Open-collector hall / geartooth / optical sensor

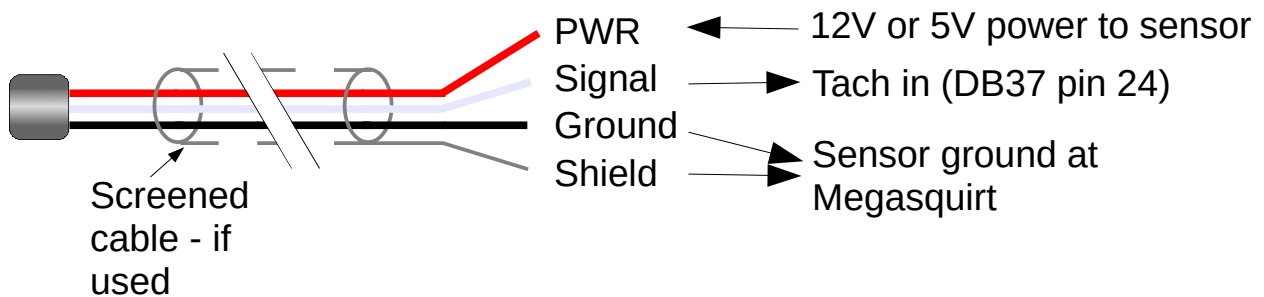

VR Input with pullup for hall sensors, LS2/58X, optical sensors or points

- a) Find JP1 in the bottom right of the board. Place a jumper across positions 1 and 2
- b) Find J1 in the middle of the board. Place a jumper across positions 3 and 4
- c) Install a 1k resistor (any value 470R - 2k2 is likely ok) onto the pads marked R57
- d) With a small screwdriver, turn the pots, R52 and R56, 7 turns anticlockwise (sometimes you may feel a "click" when the end position is reached, they can't be damaged by turning too far.) and then turn R56 back about 2 turns clockwise.

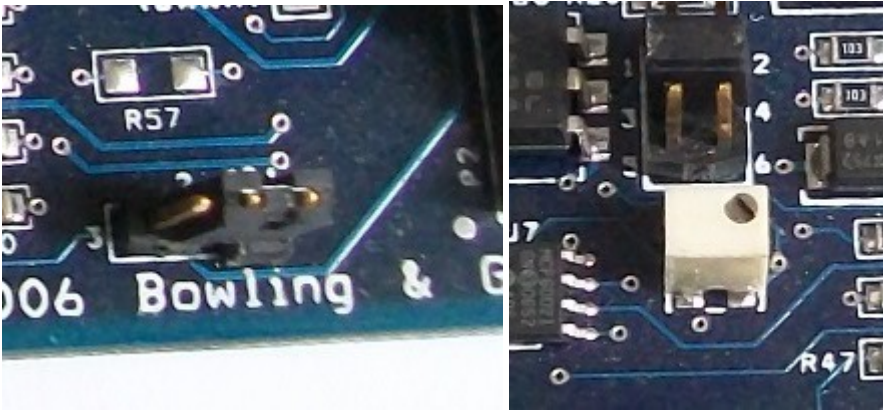

Optionally, when adjusting R56, you can measure the voltage at the "top" of R54. You'll need the board powered up. Set your meter to volts, and connect the +ve probe to the top of R54 and the -ve probe to ground. Adjust R56 to get around 2.5V on your meter.

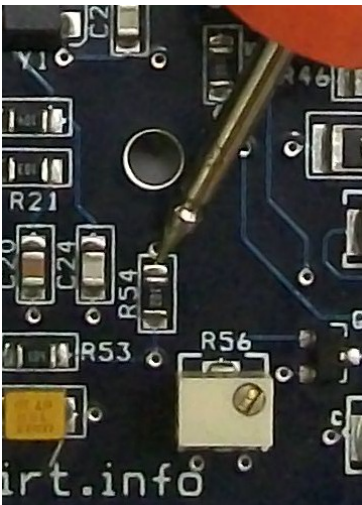

5.2.4 Hall sensor input (built-in pull-up)

These sensors operate similarly to the hall sensors in section 5.2.3 but include the pull-up resistor internally so they give a 0V or 5V signal.

Hall sensor (built-in pullup)

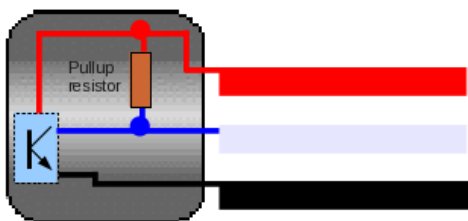

Equivalent circuit

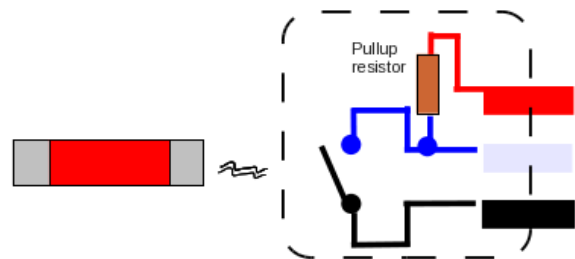

Sensor gives a ground in presence of a magnet.
Gives positive voltage with no magnet.

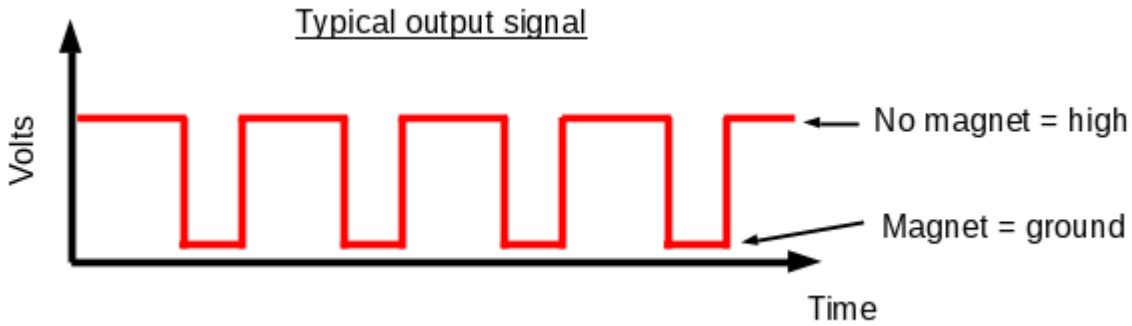

The hall sensor requires a supply voltage which is usually 12V from a fused 12V supply or 5V from the TPSREF output of the Megasquirt. The sensor is then grounded at the Megasquirt sensor ground and the signal wire connects to the Tach input.

Hall / geartooth / logic / optical sensor

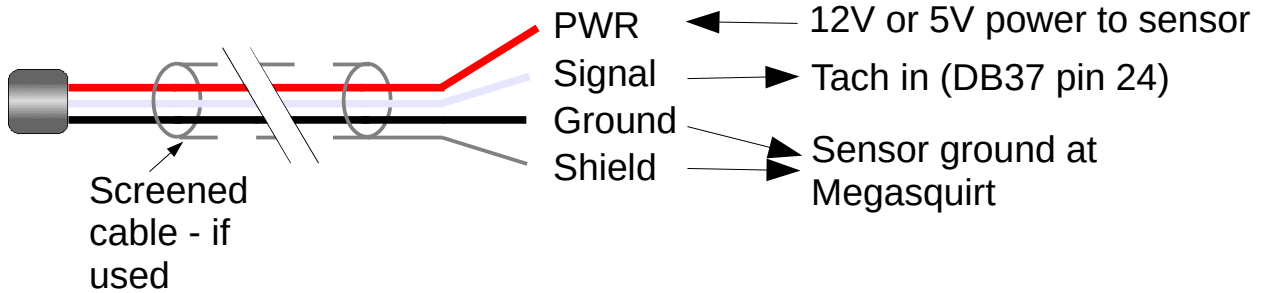

VR Input for logic input e.g. TFI, EDIS, GMDIS, LS1/24X, modules, hall sensor with built-in pullup

- a) Find JP1 in the bottom right of the board. Place a jumper across positions 1 and 2
- b) Find J1 in the middle of the board. Place a jumper across positions 3 and 4
- c) With a small screwdriver, turn the pots, R52 and R56, 7 turns anticlockwise (sometimes you may feel a "click" when the end position is reached, they can't be damaged by turning too far.)
- d) Turn R56 back about 2 turns clockwise.

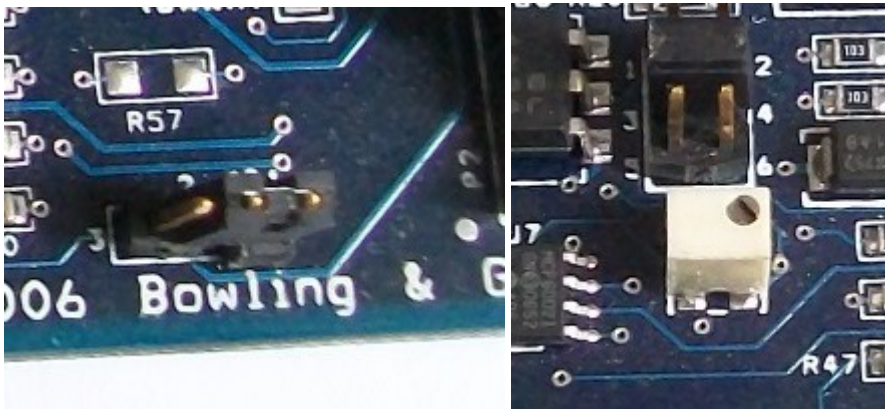

Optionally, when adjusting R56, you can measure the voltage at the "top" of R54. You'll need the board powered up. Set your meter to volts, and connect the +ve probe to the top of R54 and the -ve probe to ground. Adjust R56 to get around 2.5V on your meter.

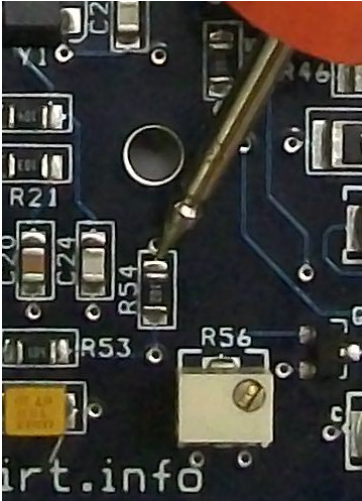

5.2.5 Gear-tooth sensor input



The gear-tooth sensor is a variant of the hall sensor - the key difference is that it has a magnet built into it and switches when close to steel, no external magnets are required. This makes them very easy to use. These are almost exclusively a three wire sensor. In CAS (crank angle sensor) units a multi-plug may be used to combine multiple sensors. The sensor itself acts like a switch to ground when close to steel.

Just like hall sensors, the gear-tooth sensor may be open-collector or have a built-in pull-up. Refer to sections 5.2.3 and 5.2.4 for more detail.

The image above shows the Honeywell 1GT101DC gear-tooth sensor, this works well for single tooth or half-moon cam wheels, but is not suitable for missing-tooth wheel installs.

DIYAutoTune.com sell a similar looking sensor that works ok on missing-tooth wheels.

5.2.6 GM LS 24X crank/cam sensors

The sensors used on the LS family of GM engines are designed to read the crank and cam triggers specific to those engines. The 24X crank pattern uses a pair of adjacent toothed wheels and requires the specific GM sensor.

The 24X style black sensors use a 12V supply and operate like a hall sensor with a built-in pull-up - putting out a 0-5V logic signal as the teeth pass.

See section 5.2.4 for generic wiring. See section 6.33 for more details on 24X installation.

24X (black) crank sensor

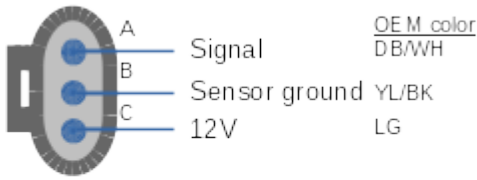

24X (black) cam sensor

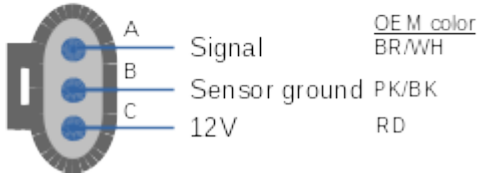

5.2.7 GM LS 58X crank/cam sensors

The sensors used on the LS family of GM engines are designed to read the crank and cam triggers specific to those engines. The 58X crank pattern uses a conventional single crank wheel.

The 58X style gray sensors use a 5V supply from TPSVREF and operate like an open-collector hall sensor as they require a pull-up resistor.

See section 5.2.3 for generic wiring. See section 6.34 for more details on 58X installation.

58X (gray) crank sensor

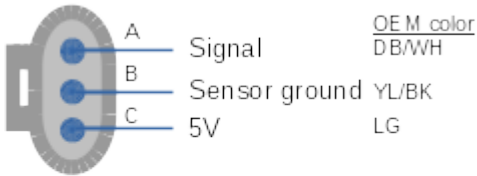

58X (gray) cam sensor

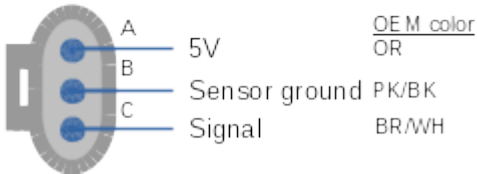

5.2.8 Optical sensor

Optical sensor

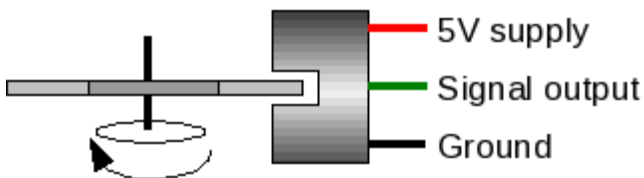

The optical sensor is another commonly used category of sensor. These are almost exclusively a three wire sensor. In CAS (crank angle sensor) units a multi-plug may be used to combine multiple sensors. The sensor itself acts like a switch to ground when light shines through the trigger disc. Optical sensors are commonly seen in distributors where vanes or shutters block the light causing the sensor to rapidly switch off and back on when

light is present again. A pull-up resistor is almost certainly required.

See section 5.2.3 for wiring.

Note: One OEM application for optical sensors is the Mitsubishi/Nissan/Optispark CAS. Megasquirt-2 does not support the 360 slit "hi-res" tach input from these CASes, see the specific manual section for configuration details.

5.2.9 Distributor points input

NOTE: re-phasing a distributor can be quite awkward - installing a toothed-wheel for tach input is strongly recommended instead.

It is possible to convert a points distributor to give a tach input to Megasquirt and have control of your timing. In this case the points now only provide a tach signal and the Megasquirt is used to control the coil. Most conventional points distributors have a mechanical advance (weights) and a vacuum canister. In the original system these change the timing depending on engine RPM and load. Now that Megasquirt will be controlling the timing you will need to lock out these mechanisms in your distributor and likely change the phasing.

Set the engine to approx 10BTDC. Rotate the distributor so that the point are just opening when the engine rotates forwards.

Now set the engine to approx 25BTDC - the rotor arm needs to be pointing directly to a tower on the distributor cap.

You will likely need to make mechanical changes (cutting, bolting, welding) inside the distributor to achieve this.

With incorrect rotor arm phasing you will very likely end up with cross-firing to the wrong cylinder.

The low-tension side of the coil must be disconnected from the distributor and is now controlled by the Megasquirt (see ignition outputs section.)

The points are grounded within the distributor and the points terminal is connected to the Megasquirt tach input.

A pull-up resistor is required in the wiring harness or inside the Megasquirt.

Set mainboard as per section 5.2.3.

Points

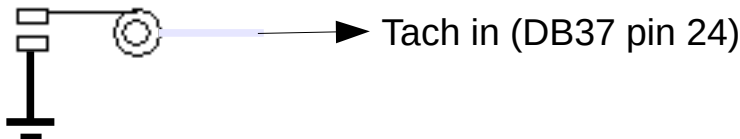

5.2.10 Combined Ignition module (TFI, EDIS, HEI, GMDIS)

Some ignition modules, particularly from the 1980s combine the tach input and coil driving ignition output within one module. All of them supply a simple square wave digital signal to the Megasquirt and should be connected to the Tach input.

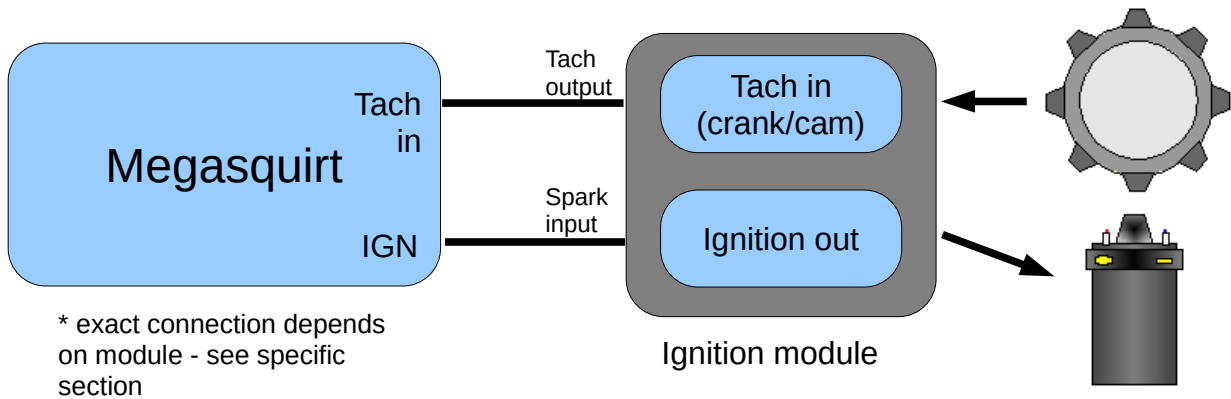

It is important to be aware that while Ford EDIS and GM DIS both have special toothed wheels, the module handles all the decoding and presents a signal to the Megasquirt that looks like a distributor input. With these two modules, the Megasquirt does not know or care how many teeth are actually on the wheel, so do not use the "toothed wheel" setting. This also means that normally you cannot use sequential fuel with these systems as no engine position information is available to the Megasquirt.

Full configuration details for these specific installs are covered in the section 6.

5.2.11 Nissan CAS

The Mitsubishi CASes used on many Nissans and GM LT1 Optispark use a dual optical pickup and a trigger disc with a high-resolution series of 360 outer slits and a low-resolution series of inner slots - one per cylinder.



Nissan CAS

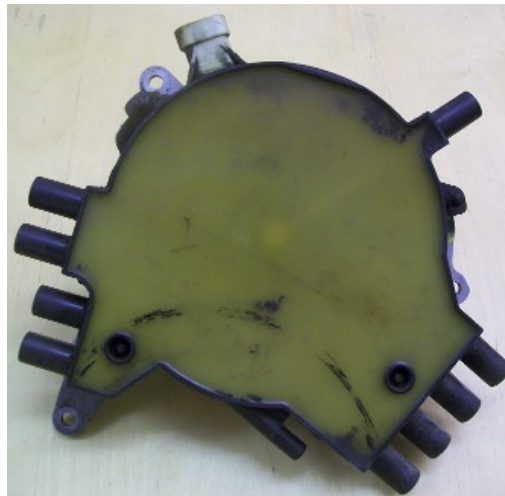

GM Optispark

The Megasquirt-3 code supports the high-resolution outer signal. Both hi-res and low-res must be connected. Specific details are in the GM Optispark (6.39), Nissan RB25 (6.41) and Nissan SR20 (6.40) ignition sections. The hi-res tach input needs to be connected to PT4 through the MS3X board.

Optionally, the low-resolution inner signal alone can be used with a single coil and distributor in "Basic Trigger" mode.

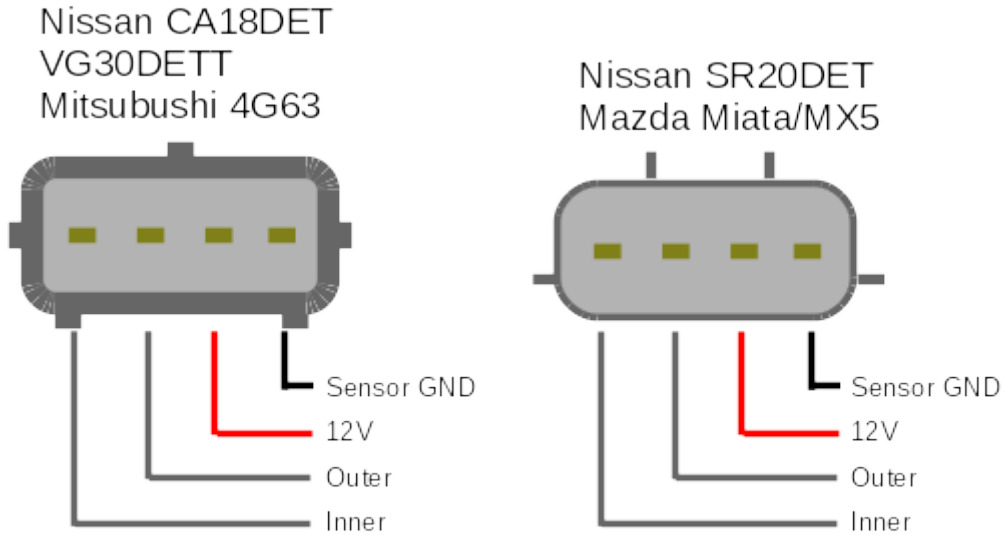

When using the stock trigger disc and "Basic Trigger", the high-resolution outer track is not used. The low-resolution inner track is connected to the Tach input.

Set the mainboard as per section 5.2.3

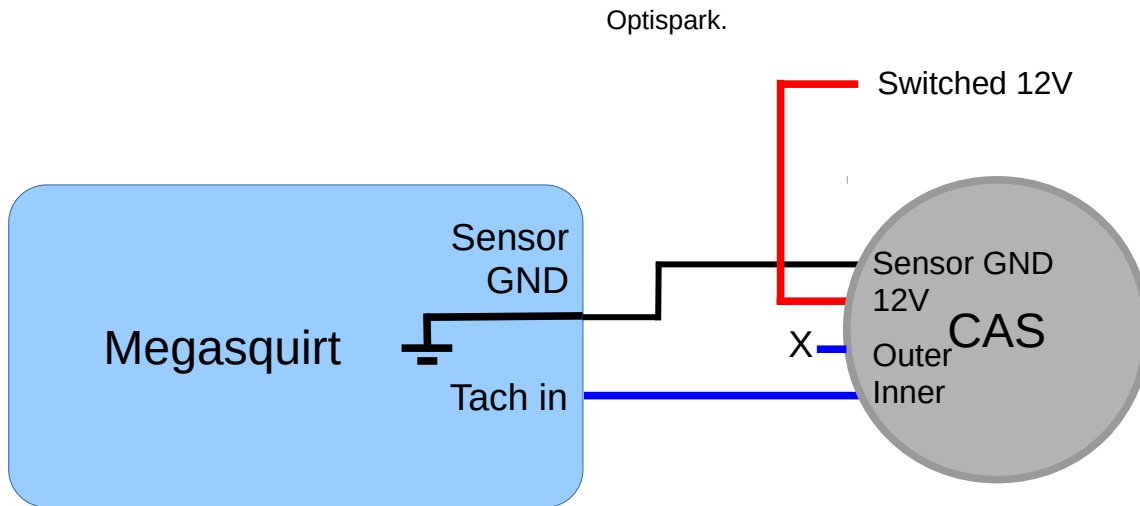

Typical settings:

Spark mode = Basic Trigger

Trigger angle/offset = Start at 10 deg - adjust while strobing timing.

Ignition input capture = ????

Number of coils = Single coil

5.2.12 4G63 / 6G72

Some other hall or optical CASes such as 4G63 (Miata) and 6G72 can be supported by special decoders for the trigger pattern.

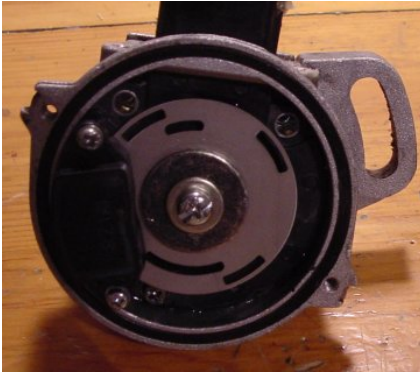

See sections 6.15 for 6G72 and 6.18 for 4G63

5.2.13 Mitsubishi CAS with aftermarket disc

As an alternative to the 360 slot CAS or low resolution 4G63, 6G72 patterns, many companies offer replacement trigger discs with standard patterns. When this kind of replacement trigger disc is installed the "Toothed Wheel" mode needs to be used - see section 6.9

5.2.14 Adding a cam sensor input

Many ignition configurations are supported using a single 'crank' tach input e.g. distributor, EDIS, wasted spark from a crank wheel etc. However, certain ignition combinations require two tach inputs 'crank' and 'cam'. e.g. coil-on-plug ignition, 4G63, 6G72 or some of the other OEM specific ignitions.

Internal modifications are required to add support for a cam sensor input on MS3V3.

An important technical note : some of the OEM specific decoders compare the crank and cam signal polarities, the main tach input inverts the incoming signal, so the added cam tach input must do the same. The suggested circuits here respect that requirement.

5.2.14.1 Adding a cam sensor input - VR/magnetic sensor

For the DIYer, the most straightforward circuit for the cam input is based on the LM1815N chip. (An alternative would replicate the crank circuit, but for the DIYer there are significantly more components.)

Build the following circuit on prototype board. The input pin chosen on the main DB37 connector is your choice.

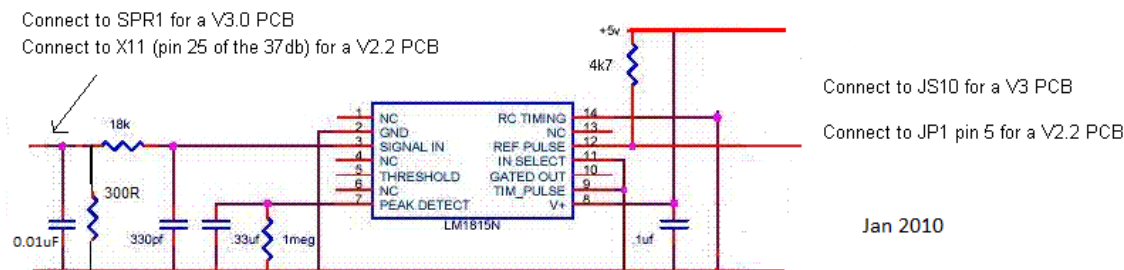

5.2.14.2 Adding a cam sensor input - open-collector hall sensor / optical sensor

This option uses the spare opto-isolator on the mainboard for the cam input and matches the polarity inversion of the VR/universal tach input.

This section is for open-collector sensors as covered in 5.2.3 that ground switch only.

a) JP1/pin3 should be connected with a jumper wire to a spare pin on the main DB37 connector (e.g. SPR3) - this is your cam input.

- b) Connect J1/pin1 with a jumper wire to JS10 (ensuring that nothing else is connected.)
- c) Jumper XG1 - XG2
- d) Check that R12 is a 390R to 470R resistor, replace if not.
- e) Solder wires onto a 470R 1/4W resistor and cover in heat-shrink.
- f) Connect one wire to +5V
- g) Connect the other wire to JP1/pin3 (joining the jumper wire there.)
- h) Ensure that C30 is not fitted.

5.2.14.3 Adding a cam sensor input - hall or logic sensor

This option uses the spare opto-isolator on the mainboard for the cam input and matches the polarity inversion of the VR/universal tach input.

This section is for sensors as covered in 5.2.3 that put out a 0-5V signal.

- a) JP1/pin3 should be connected with a jumper wire to a spare pin on the main DB37 connector (e.g. SPR3) - this is your cam input.
- b) Connect J1/pin1 with a jumper wire to JS10 (ensuring that nothing else is connected.)
- c) Jumper XG1 - XG2
- d) Check that R12 is a 390R to 470R resistor, replace if not.
- e) -not required-
- f) -not required-
- g) -not required-
- h) Ensure that C30 is not fitted.

5.2.14.4 Adding a cam sensor input - ground switching

This option uses the spare opto-isolator on the mainboard for the cam input, with the sensor in ground-switching mode. This will usually give more reliable operation, but it does not match the polarity inversion of the VR/universal tach input - this is not a problem in "Toothed wheel" mode.

- a) JP1/pin3 should be connected with a jumper wire to +5V.
- b) Connect J1/pin1 with a jumper wire to JS10 (ensuring that nothing else is connected.)
- c) Jumper XG1 to a spare pin on the main DB37 connector (e.g. SPR3) - this is your cam input.
- d) Check that R12 is a 390R to 470R resistor, replace if not.
- g) Ensure that C30 is not fitted.

5.3 Ignition outputs

The MS3X output has provision for eight sequential logic spark outputs. The mainboard has provision for a single high-current ignition output as standard.

On regular ignition installs, the ignition outputs must be connected in firing order sequence.

e.g. a 4-cyl engine with coil-on-plug and a 1-3-4-2 firing order would connect A=1, B=3, C=4, D=2

Rotary engines are wired differently - refer to the specific section.

 Double check your Spark Output setting - this is a critical !
Setting it incorrectly could result in melted coils.

 It is strongly advised that ignition coils are powered from the fuel-pump relay. This ensures that the coils can only be powered when the engine is running.

The diagram below shows the signal source for each of the ignition outputs - they all require an interface circuit - do not connect these directly!

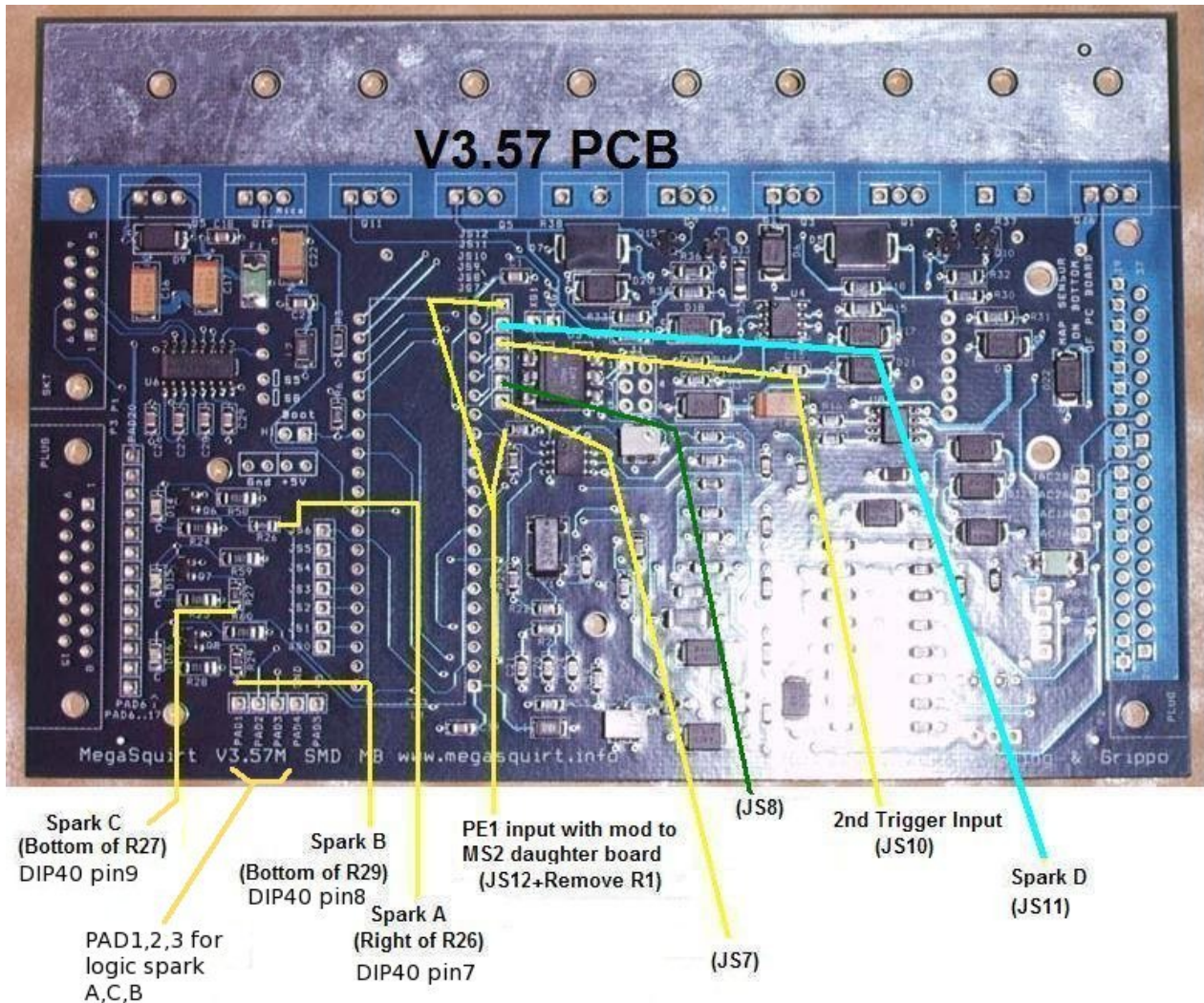

Output	Resistor	CPU pin
Spark A	Top of R26	7
Spark B	Top of R29	8
Spark C	Top of R27	9
Spark D	JS11	18
Spark E	JS4	30
Spark F	JS5	29

5.3.1 Building ignition outputs

5.3.1.1 High current output (one)

This provides a single high-current ignition output suitable for directly driving one inductive coil.

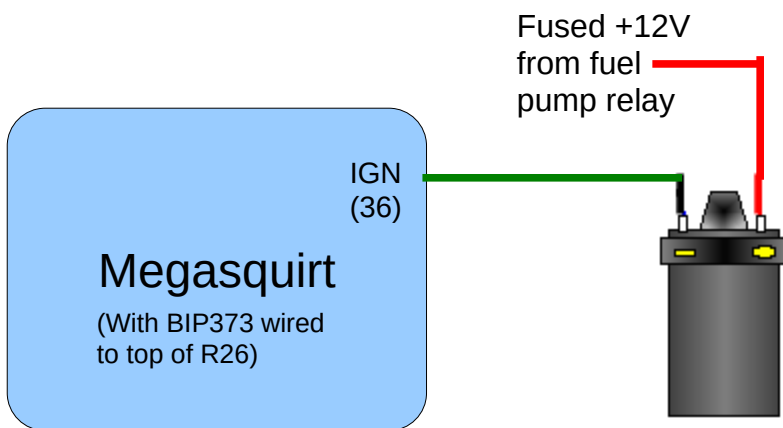

Internally, the follow is required:

- BIP373 (marked as 30115) needs to be installed in Q16 with a mica insulator.
- Connect a 330R 1/4W resistor between IGBTin and CPU pin 7 (or the top of R26)

Typical settings

Spark Output = Going High

Dwell Type = Standard Dwell

Dwell ~ 3ms for a standard coil

5.3.1.2 High current output (additional)

Additional BIP373 drivers can be installed inside the Megasquirt case. The simplest way is to buy a second heatsink bar and install it above the existing one. Extra BIP373 can be bolted on with the correct mica insulator.

The high current ignition outputs can be routed through a spare pin on the DB37 connector or through an additional connector. If using spare pins on the DB37 be sure that the board traces are thick enough. e.g. SPR1,2,3,4 have thin traces from the pads to the connector - these need a jumper wire in parallel. (A spare leg from a resistor will do the job.)

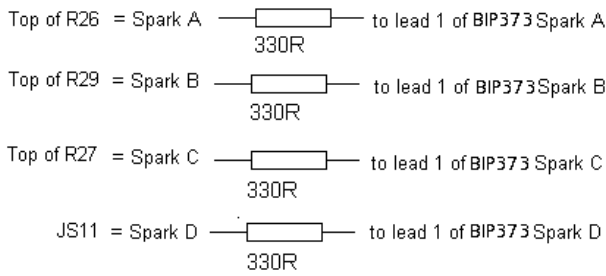

Spark A + B needed for 4cyl wasted spark
 Spark A + B + C needed for 6cyl wasted spark
 Spark A + B + C + D needed for 8cyl wasted spark

Note: The 330R base resistor is preferred, but if two VB921 are run from one spark output, you need to use 680R on each instead to avoid overloading the MS2 card

Note:
 This db15 connector is NOT the V3.57 connector, it is an additional connector for the V3.0 PCB!!!

Lead 2 of BIP373s go to the DB15 connector

- Lead2 for Spark A = pins 1+2
- Lead2 for Spark B = pins 3+4
- Lead2 for Spark C = pins 5+6
- Lead2 for Spark D = pins 7+8

Link all pin 3's of the BIP373 together like this connect to pins 9 and 10 of the DB15

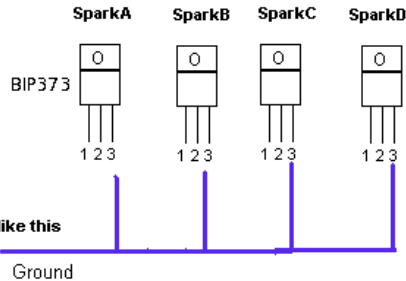

Schematic Diagram

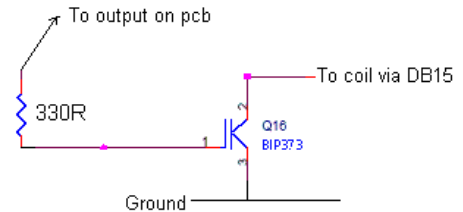

5.3.1.3 Logic spark outputs - FET driver method

This circuit is suitable for driving LS1 type coils and many other logic coils including VW COPs with a low input impedance. See also section 5.3.0.4 for a simple method.

With this wiring the Spark output must be set to "Going High".

Pros:

- Can drive most logic coils including low resistance VAG COPs.
- Coils do not receive a spurious signal pulse at power on.
- Uses standard "Going High" setting.

Cons:

- There is no prototype area on the V3.57 board, so this is more difficult to install.
- Requires additional components.

Build the following circuit(s) on prototype board.

Parts required for two channels:

TC4427AEPA

2x 15R 1/8W resistors

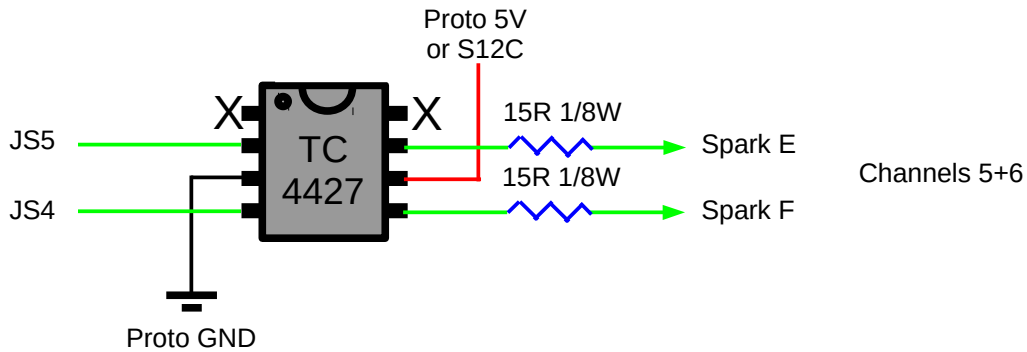
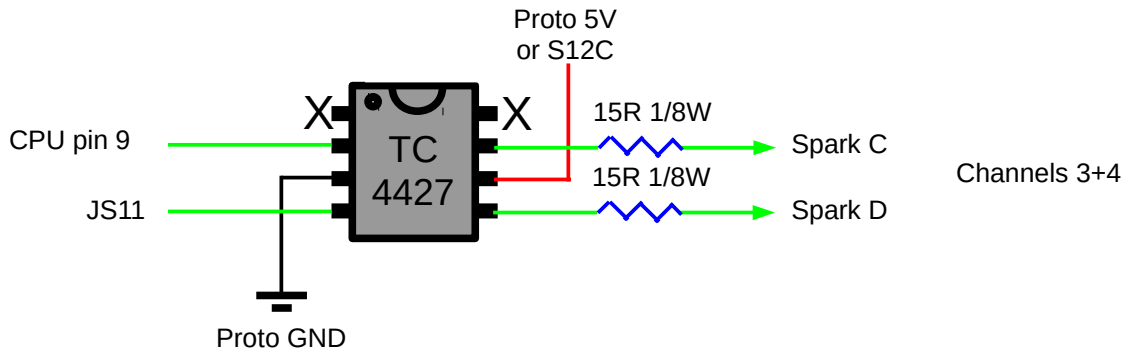
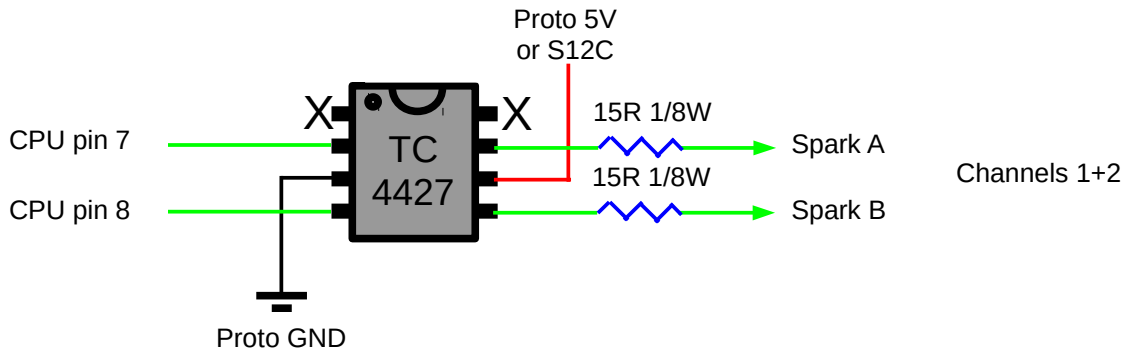

The Spark A,B,C etc. outputs need to be jumpered to the connector of your choice.

5.3.1.4 Logic spark outputs - resistor method

This section shows a simple method for wiring logic outputs. (This circuit is commonly shown in documentation prior to July 2014.)

With this wiring the Spark output must be set to "Going Low".

Pros:

- Simple to wire in.
- No additional components required for Spark A,B,C.

Cons:

- Coils receive a spurious pulse at power on.
- Cannot drive some VAG COPs.

The V3.57 has three logic outputs available already. The PAD1,2,3 connections should be jumpered to an output pin of choice (e.g. SPR3) and can drive many logic coils.

Spark output	Pin
Spark A	PAD1
Spark B	PAD3
Spark C	PAD2

If 4th, 5th or logic channels are required, **build additional transistor circuits** with the inputs JS11, JS5 or JS4 respectively and route the output from the circuits to spare output pins of your choice.

e.g. for Spark D, connect JS11 to "from MS3" and connect "spark output" to your output connector pin.

Spark output	Pin
Spark D	JS11
Spark E	JS4
Spark F	JS5

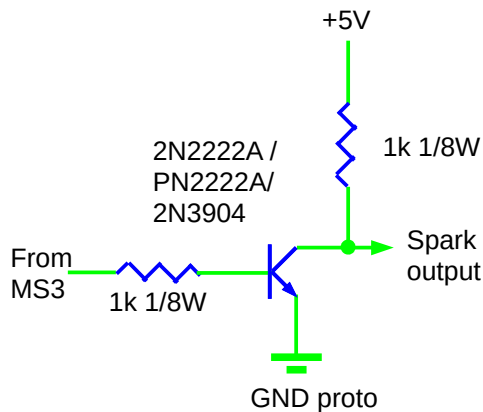

5.3.1.5 V3.57 DB15 connector

The V3.57 mainboard provides a spare DB15 connector that is ideal for additional DIY logic inputs and outputs.

Note that external connections must never be connected directly to the MS3 card. A buffer or interface circuit is always required. It is safe to connect the PAD1,2,3 connections as these are already buffered.

If using high-current spark outputs the traces to the DB15 plug will need beefing up as they are too thin for the current. A small piece of wire or leg from a resistor can be used.

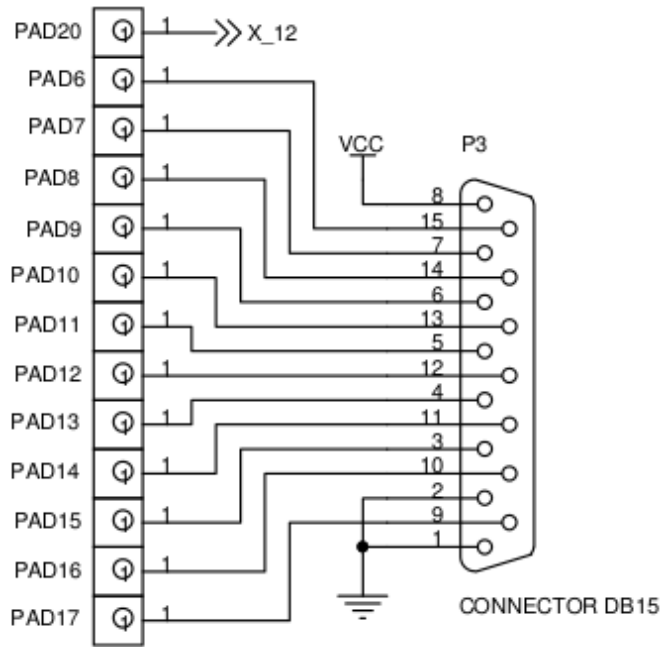

5.3.2 Logic coils

These coils can directly accept the 0-5V logic level signal from the Megasquirt. They contain an ignition driver and a coil within the package.



LS1 (left), LS2 (middle), Truck (right) coils

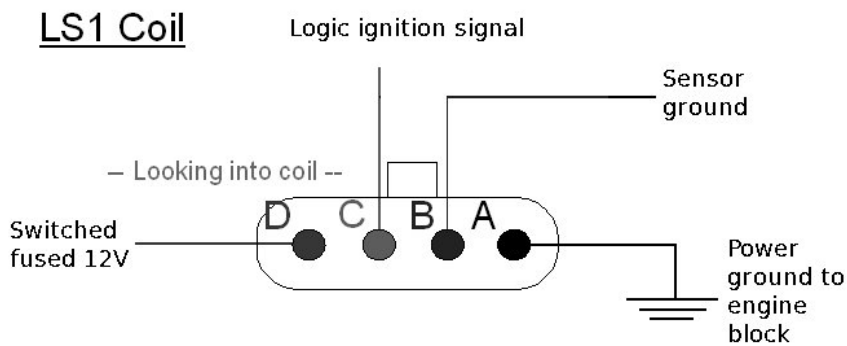

A dwell figure of 3.5ms is advised for LS1 coils.(was 4.5)

Note that some coils have a built-in over-dwell protection feature. If given too much dwell the coil will automatically spark. This can give a dangerous advanced spark. Be sure to strobe your timing at high revs to ensure this is not happening.

Set the Spark Output to Going High. Build circuit in section 5.3.1.3

LS2 Coil

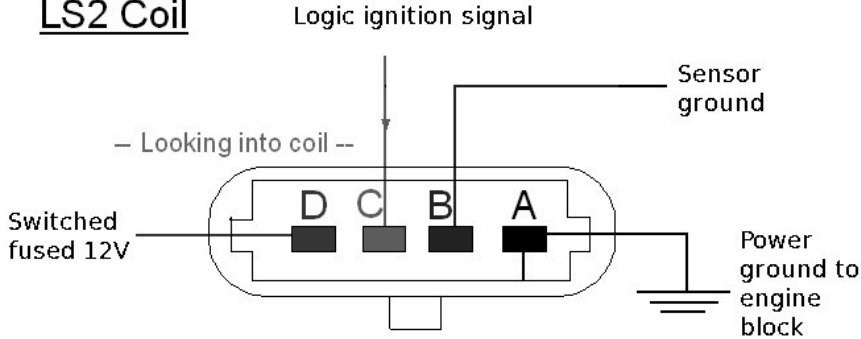

A dwell figure of 3.5ms is advised for LS2 coils. (was 4.5)

Note that some coils have a built-in over-dwell protection feature. If given too much dwell the coil will automatically spark. This can give a dangerous advanced spark. Be sure to strobe your timing at high revs to ensure this is not happening.

Set the Spark Output to Going High. Build circuit in section 5.3.1.3

D585 truck coil

	<p>Pin-out A = Power ground to engine block B = Signal ground (connect to sensor ground) C = Spark input signal D = 12V supply</p> <p>Common colors: A = black B = brown C = varies per coil D = pink</p>
--	--

A dwell figure of 3.5ms is advised for truck coils.

Note that some coils have a built-in over-dwell protection feature. If given too much dwell the coil will automatically spark. This can give a dangerous advanced spark. Be sure to strobe your timing at high revs to ensure this is not happening.

Set the Spark Output to Going High. Build circuit in section 5.3.1.3

LS coilpack multi-plug

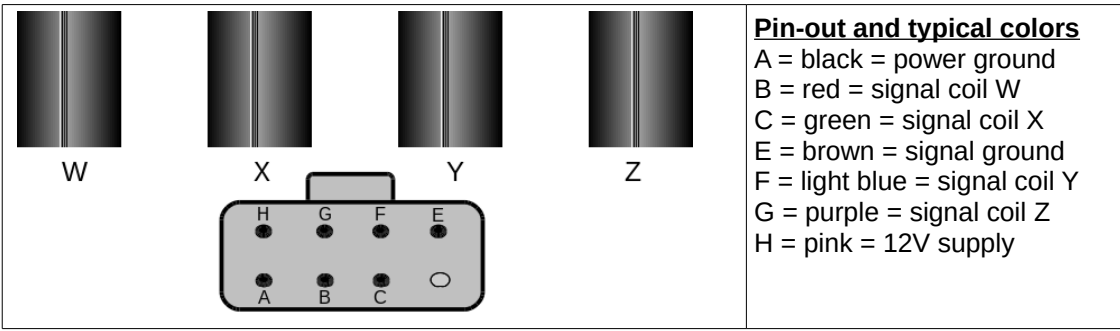

General layout for 4-cyl coil-on-plug using LS coils

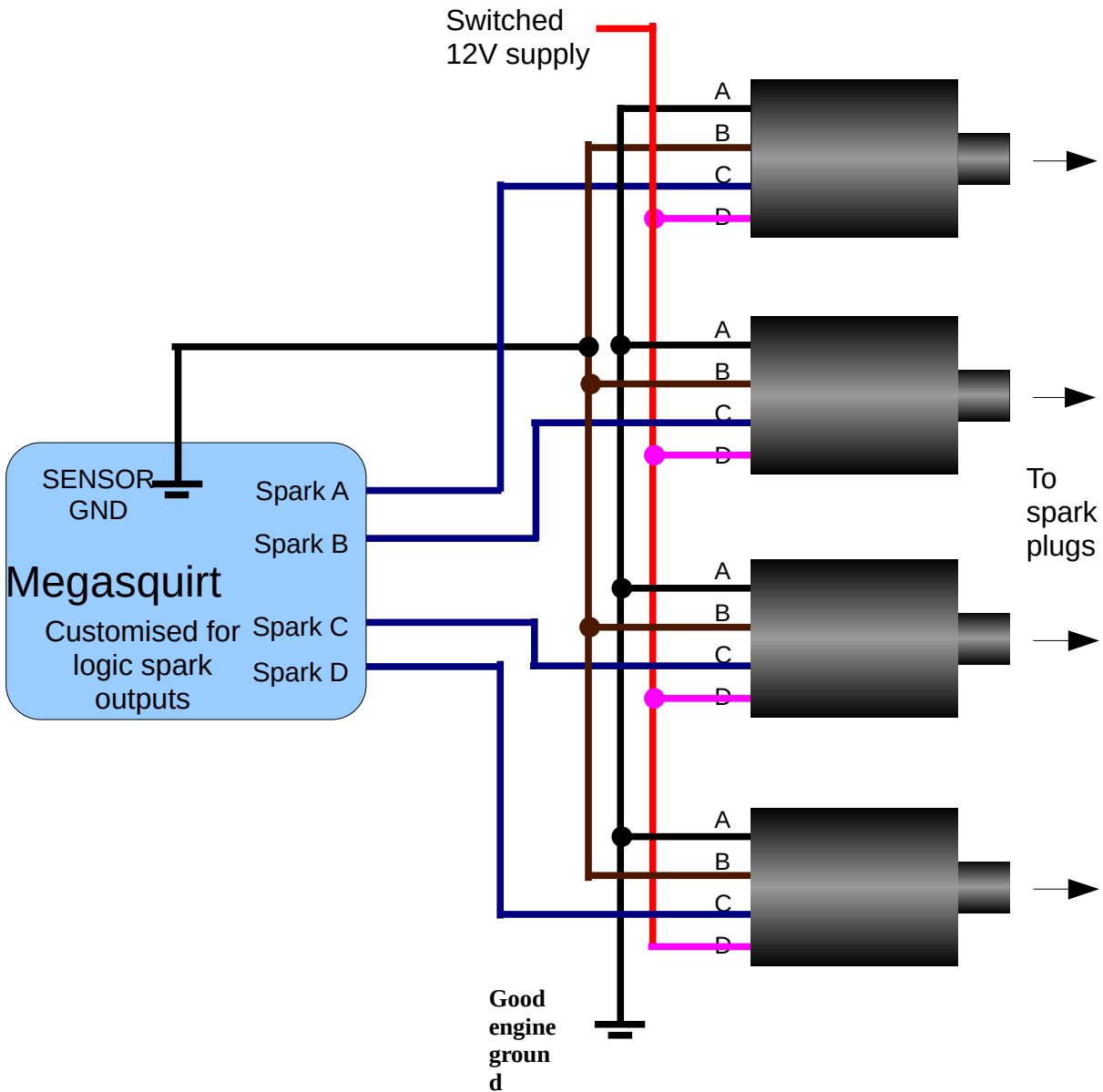

Set the Spark Output to Going High. Build circuit in section 5.3.1.3

IGN1A logic coil



- A - Ignition signal from Megasquirt
 - B - Logic ground, connect to Megasquirt sensor ground
 - C - Spark wire ground, connect to cylinder head
 - D - Power ground, connect to battery negative
 - E - 12 volt power (switched and fused)
- Set the Spark Output to Going High. Build circuit in section 5.3.1.3

This is a high energy aftermarket logic coil available from DIYAutoTune.com.

0 004- 402 001 - single logic coil



Pin-out

- 1 = Power Ground (Brown)
- 2 = Spark input signal 1 (Black/Red)
- 3 = 12V supply (Black)

Set the Spark Output to Going High. Build circuit in section 5.3.1.3

Fitted to many VAG vehicles including 2.0 litre mk3 Golfs 1993-1999. Designed to be used as a single coil with a distributor.

Intermotor 12916

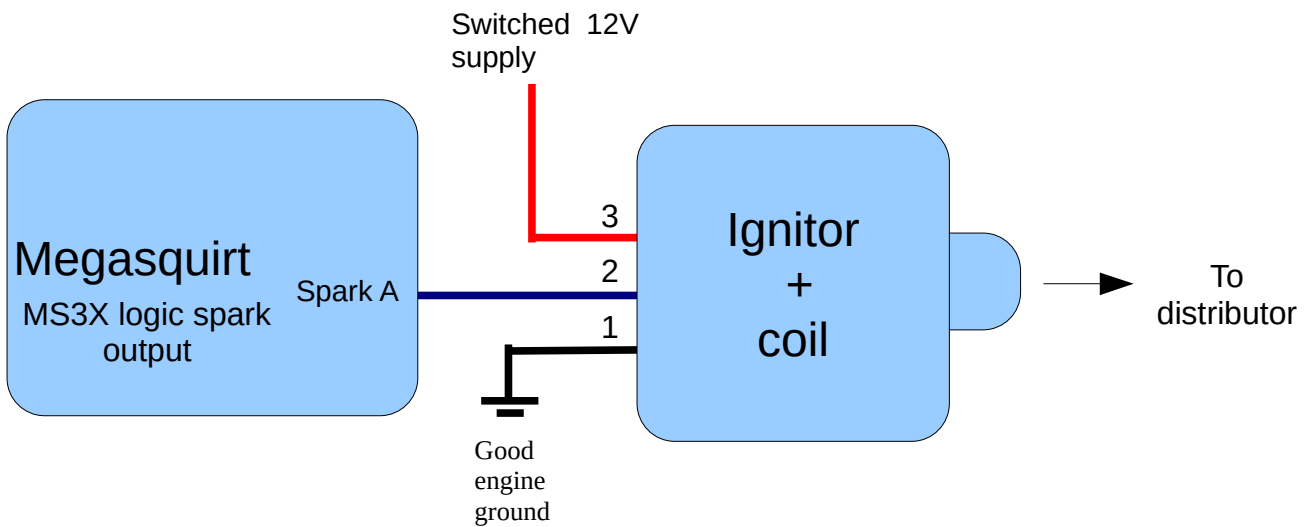

032 905 106B - 4 tower wasted spark logic coil



Pin-out

- 1 = Spark input signal 1
- 2 = 12V supply
- 3 = Spark input signal 2
- 4 = Power Ground

Set the Spark Output to Going High. Build circuit in section 5.3.1.3

The connector is 1J0 973 724

This cost effective OEM logic wasted coil has a built-in ignitor.

Fitted to many VAG vehicles including 1.6 litre mk4 Golfs.

Intermotor 12919

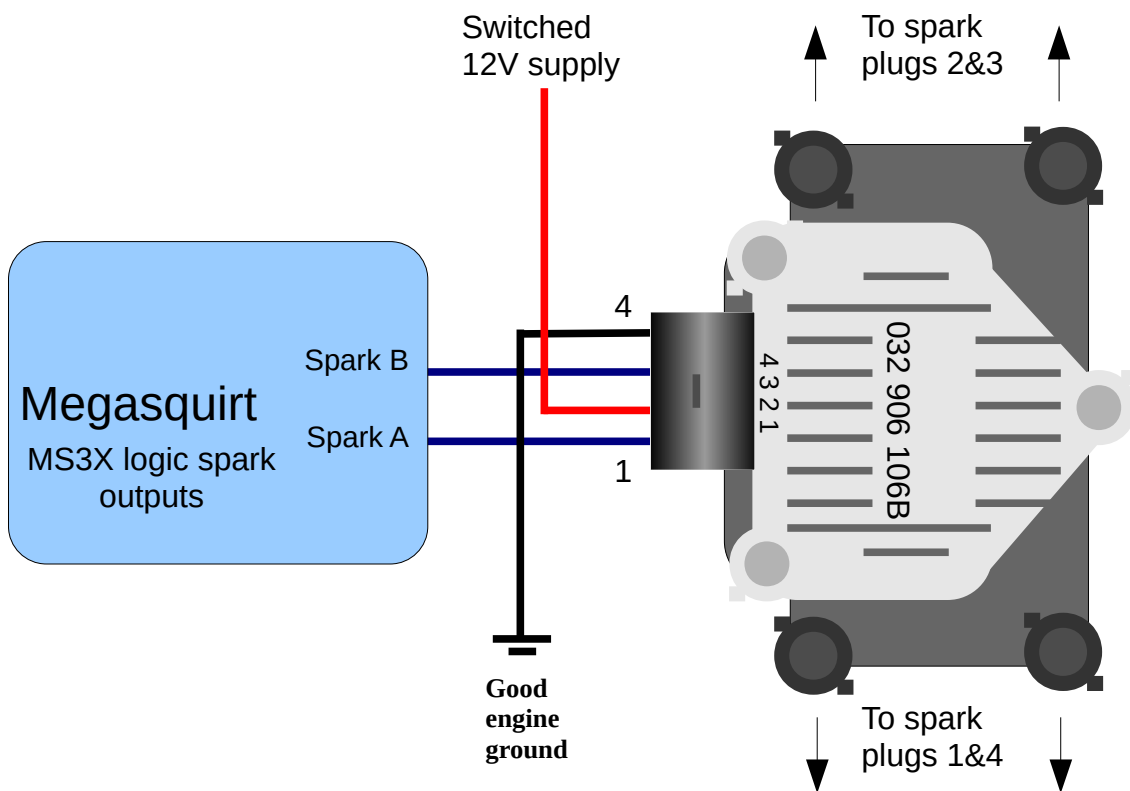

06A905097 - 4 way logic coil



4 way logic coil from VW Golf / Jetta, Skoda Octavia

Uses part numbers 0040102029, 06A905097, 06A905104, ZSE029

The connector is a polarised Bosch Kompact 6 way. 1J0973726 - 6 Way Sealed Female Connector. The contacts are 2.8 mm

Set the Spark Output to Going High. Build circuit in section 5.3.1.3

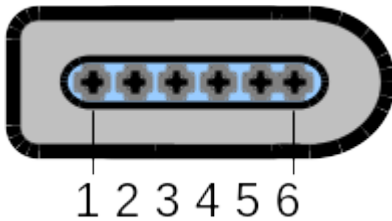

Pin-out

- 1 = Power Ground
- 2 = Spark input signal 1
- 3 = Spark input signal 2
- 4 = Spark input signal 3
- 5 = Spark input signal 4
- 6 = 12V supply

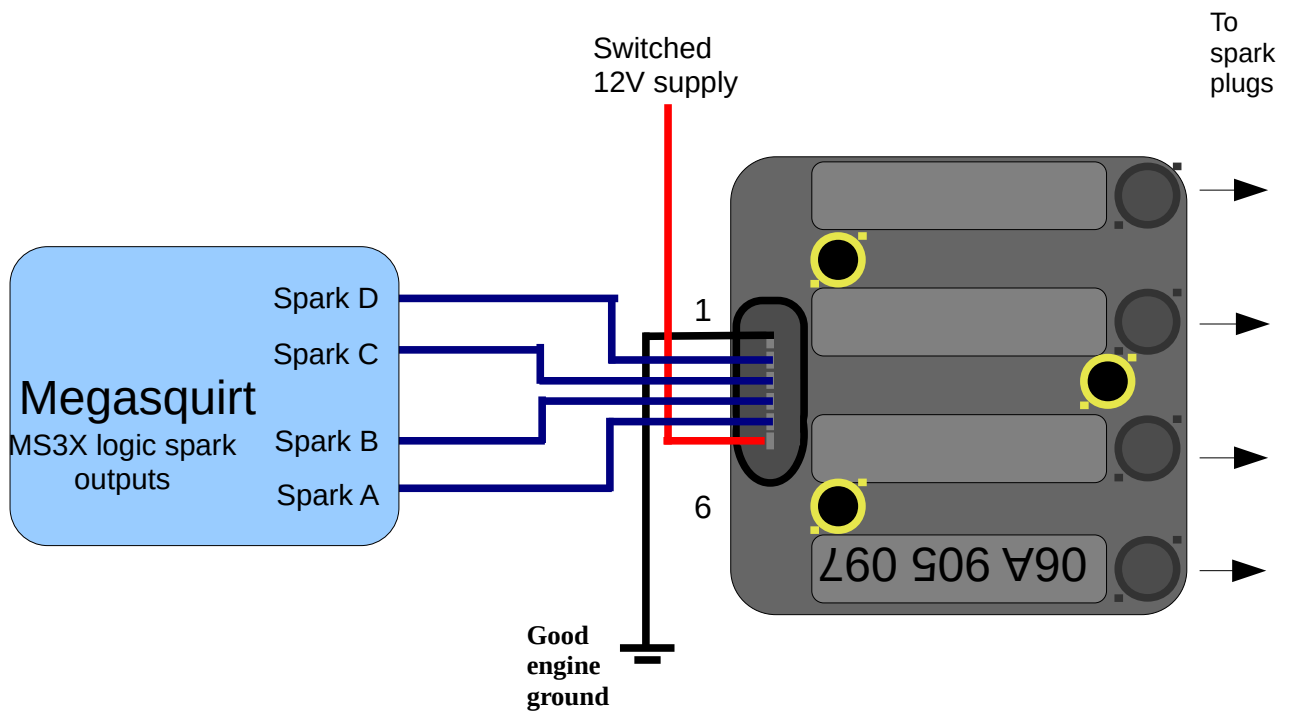

06B 905 115 - 4 wire logic COP



VAG P/N 06B 905 115 COPs: used on VW 1.8t and may other VAG cars.

Pin 1: Connects to Pin 1 on all other coils and then to +12v ignition feed (or fuel pump relay)

Pin 2: Signal ground (connect to engine block)

Pin 3: Spark Signal from Megasquirt

Pin 4: Power ground (connect to engine block)

Earlier than 2001 coils, PN - 06B 905 115, 06B 905 115 rev B and E.

These have an input resistance of ~1k and should work OK with the Megasquirt outputs.

Cranking dwell = 4.0ms Running dwell= 3.0ms

Set the Spark Output to Going High. Build circuit in section 5.3.1.3

Later than 2001 coils, PN 06B 905 115 rev L and R have a low input resistance. The MS3X logic outputs cannot drive these coils directly - see the MS3base/V3.57 manual for example circuits or use an external buffer designed for these coils.

Aside from these specific examples, there are many generic 3, 4, 5 wire COPs that can be used with the Megasquirt.

Before using an "unknown" coil it is necessary to check the resistance to ground on the input.

Using a multimeter set to resistance, check between the Spark Signal Input and Signal Ground.

If you have a reading of say ~1k then the Megasquirt MS3X outputs can be used directly.

Logic level 3 wire

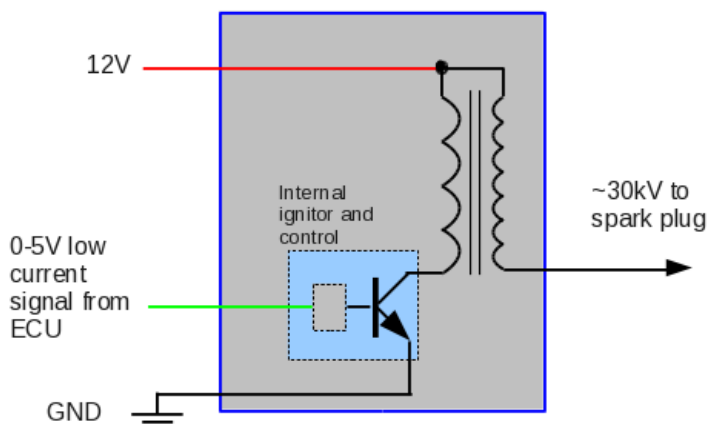

3-wire COPs are ambiguous, many are high-current (needing an ignitor), some may be logic level with a built in driver. Perform a resistance check on the signal input to confirm. High current will have an input resistance to 12V of a few ohms only.

Logic level 4 wire

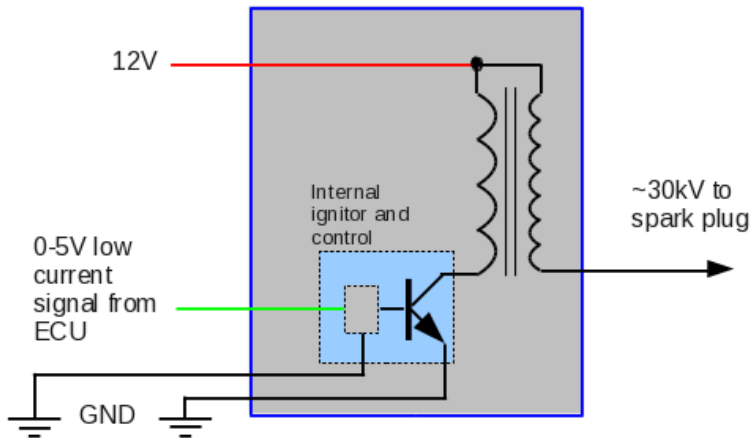

COPs with 4 or 5 wires have a built in amplifier (ignitor) so they require that you build the circuit in section 5.3.1.3 and set the Spark Output to Going High.

5.3.3 Amplifiers (ignitor, power transistor, ignition module)

An ignition amplifier module takes a 5V logic signal from the Megasquirt and drives a high-current ignition coil. This can be advantageous to keep ignition noise outside of the Megasquirt, or your engine may already have one.

There are many different modules available on the market with 1, 2, 4 ignition channels.



Bosch style 1, 2, 4 channel ignitors and Quadspark 4 channel ignitor.

Bosch 0 227 100 124

Cross references Intermotor 15015.

This single channel module can be used to drive a single high-current coil. Dwell is controlled by the Megasquirt.

Set the Spark Output to Going High. Build circuit in section 5.3.1.3

Pin-out

- 1 = Coil negative output
- 2 = Power Ground
- 3 = Input screen (if used)
- 4 = 12V supply
- 5 = Spark input signal

6 = NC
(7 = NC)

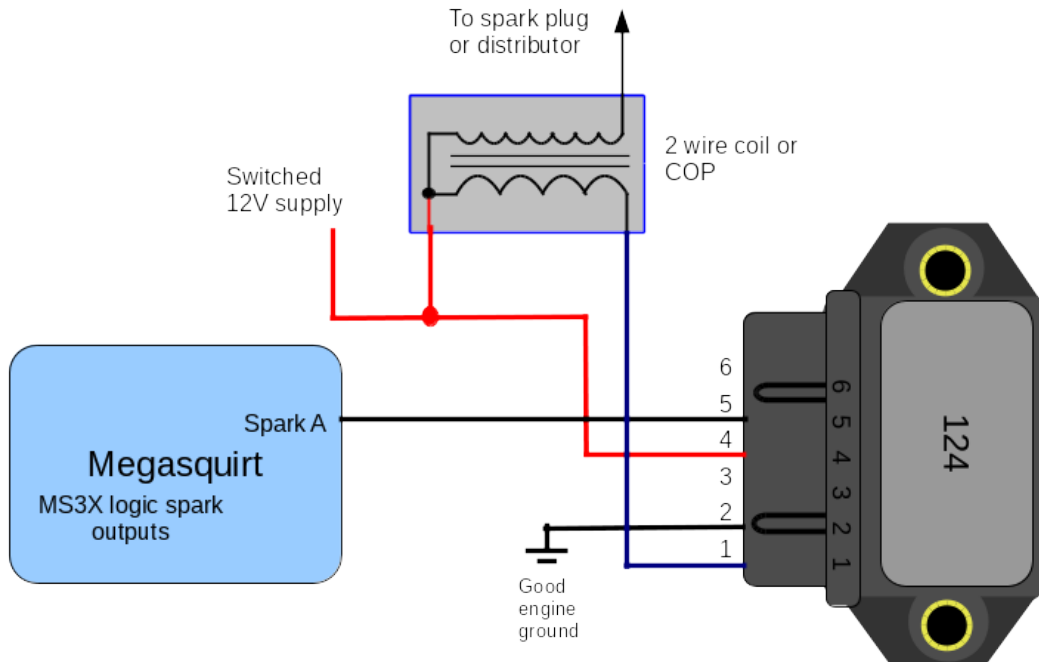

Bosch 0 2227 100 137

This is very similar to the 124 but the spark input signal is on pin 6.

Bosch 0 227 100 200

Cross references Intermotor 15867.

This dual channel module can be used to drive a high-current wasted spark coil-pack for full spark control on a four-cylinder engine, or a pair of COPs on a two-cylinder engine. Dwell is controlled by the Megasquirt.

Set the Spark Output to Going High. Build circuit in section 5.3.1.3

Pin-out

- 1 = Coil negative output 1
- 2 = Spark input signal 1
- 3 = NC
- 4 = Power Ground
- 5 = NC
- 6 = Coil negative output 2
- 7 = Spark input signal 2

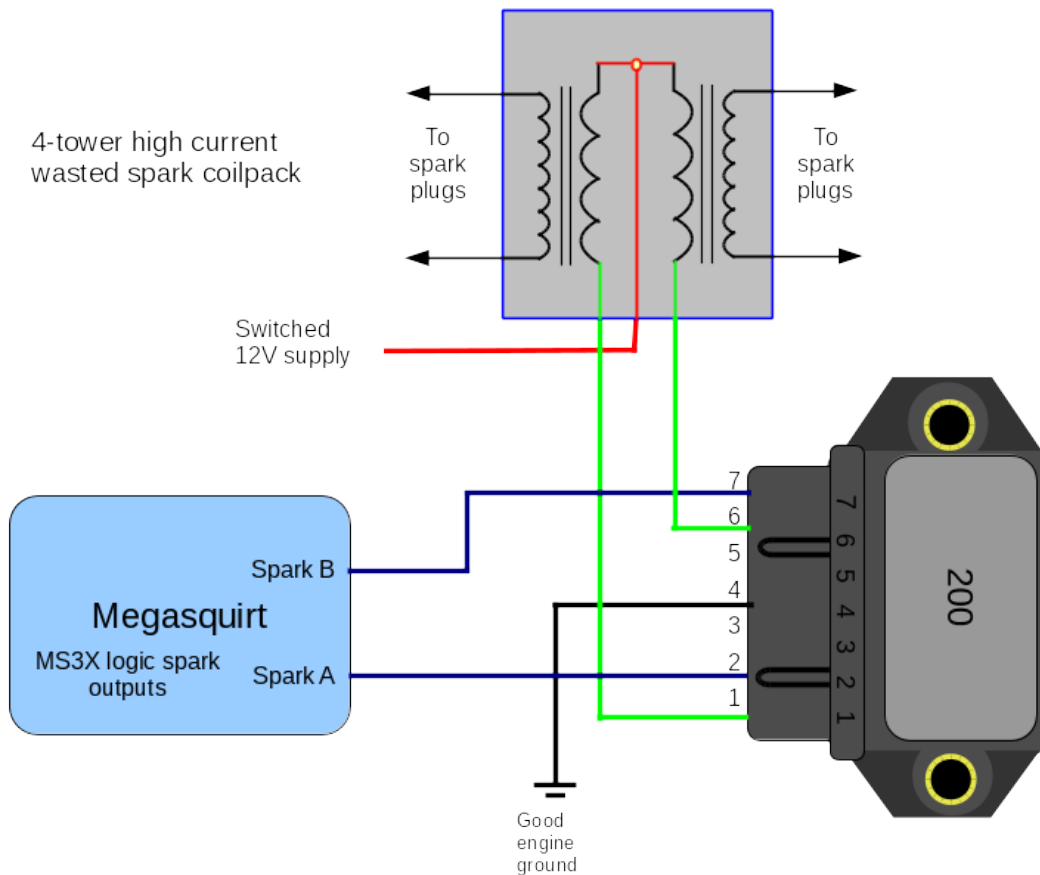

Bosch 0 227 100 211

Cross references Intermotor 15857. Typically used on VW Golf 1.8t yr 2000.

This four channel module is typically used to drive four COPs on a four-cylinder engine, it could also be used to drive a pair of high-current wasted spark coil-packs for full spark control on an eight cylinder engine. Dwell is controlled by the Megasquirt.

Set the Spark Output to Going High. Build circuit in section 5.3.1.3

Pin-out (5 pin)

- 1 = Spark input signal 1
- 2 = Spark input signal 2
- 3 = Power Ground
- 4 = Spark input signal 3
- 5 = Spark input signal 4

Pin-out (4 pin)

- 1 = Coil negative output 4
- 2 = Coil negative output 3
- 3 = Coil negative output 2
- 4 = Coil negative output 1

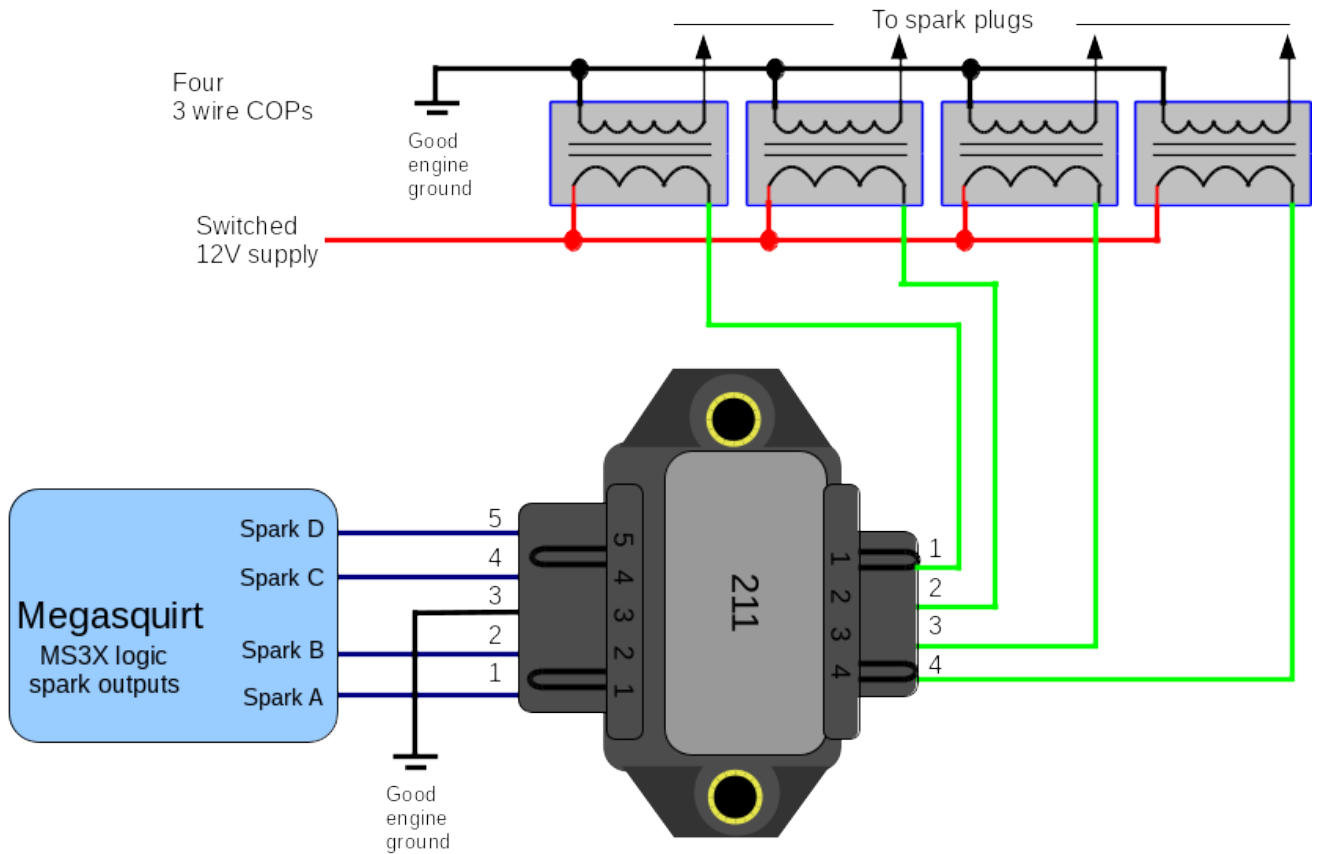

Quadspark



This aftermarket four channel module operates similarly to the Bosch 211, but is typically more cost effective.

Pin-out	Thickness	Function
Yellow	20 gauge	Spark Input A (from Megasquirt)
White	16 gauge	Spark Output A (to coil negative)
Orange	20 gauge	Spark Input B (from Megasquirt)
Pink	16 gauge	Spark Output B (to coil negative)
Dark green	20 gauge	Spark Input C (from Megasquirt)
Light Green	16 gauge	Spark Output C (to coil negative)
Blue	20 gauge	Spark Input D (from Megasquirt)
Violet	16 gauge	Spark Output D (to coil negative)
Black	4 x 14 gauge	Ground (to engine block or cylinder head)

Recommended - build circuit in section 5.3.1.3. Set the Spark Output to Going High.

The wiring in section 5.3.1.4 is not recommended.

As an alternative, install 330R resistors in the prototype area. Use a jumper wire to connect one end of the resistor to the CPU spark signal and a second jumper wire to the chosen DB37 connector pin. Set the Spark Output to Going High.

Output	Resistor in	Resistor out
Spark A	Top of R26	IGN
Spark B	Top of R29	your choice
Spark C	Top of R27	your choice
Spark D	JS11	your choice
Spark E	JS4	your choice
Spark F	JS5	your choice

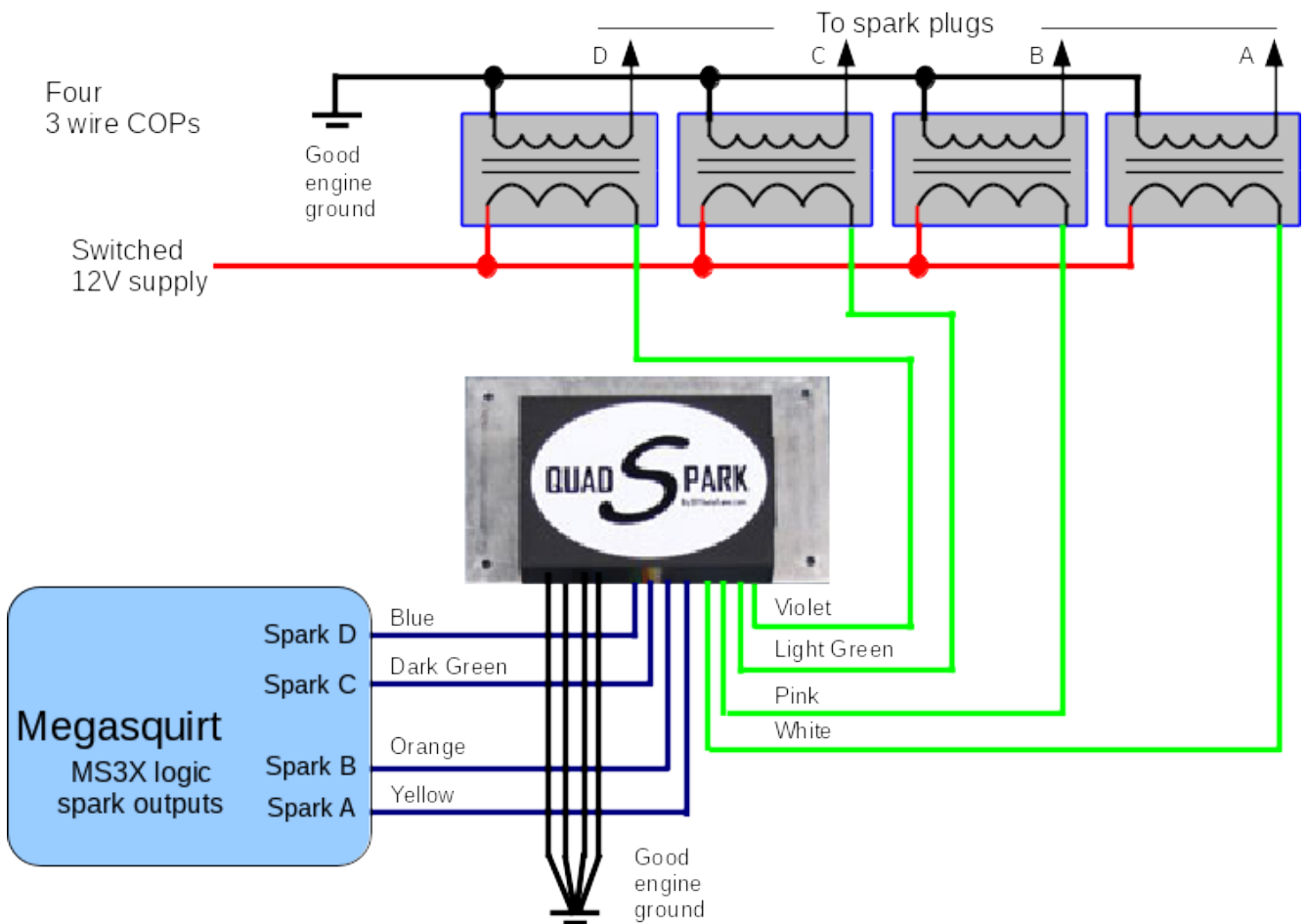

The diagram shows connection to COPs, but the module can also be used to drive high current coilpacks (Ford, Chrysler etc.)

5.3.4 High current coils

This type of coil requires a high current driver as per section 5.3.1.1 or an amplifier as per section 5.3.3



Shown are conventional single coil, GM wasted spark coil, Ford wasted spark coil-pack, Renault 2-wire COP. All of these coils are high current coils and require an ignition amplifier module (ignitor) to connect to the Megasquirt.

3-wire COPs are ambiguous, many are high-current (needing an ignitor), some may be logic level with a built in driver. Perform a resistance check on the signal input to confirm. On a high current coil two pins will have a resistance between them of approximately 0.5-1.0 ohms.

High current 2 wire

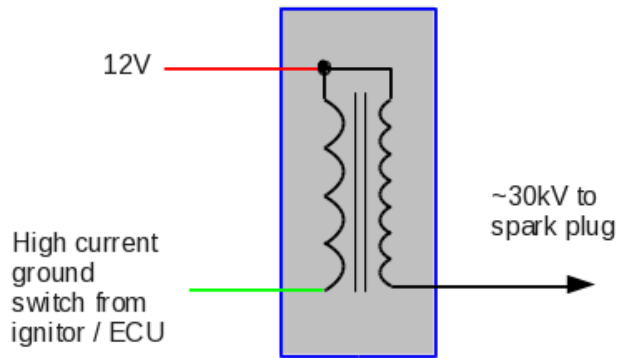

Conventional coils and "dumb" 2-wire COPs.

The connections are :

- switched/fused 12V supply
- output from ignitor.
The resistance measured between the inputs will be a few ohms only.

Requires an ignitor or customization for high current outputs.

High current 2 wire wasted spark

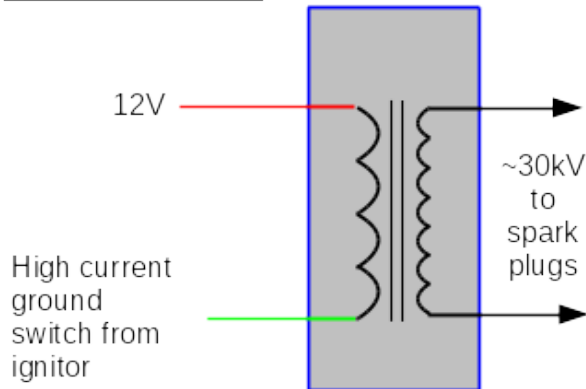

2 wire wasted spark coils - like the GM coil.

The connections are :

- switched/fused 12V supply
- output from ignitor.
The resistance measured between the inputs will be a few ohms only.

Requires an ignitor or customization for high current outputs.

4-tower high current wasted spark coilpack

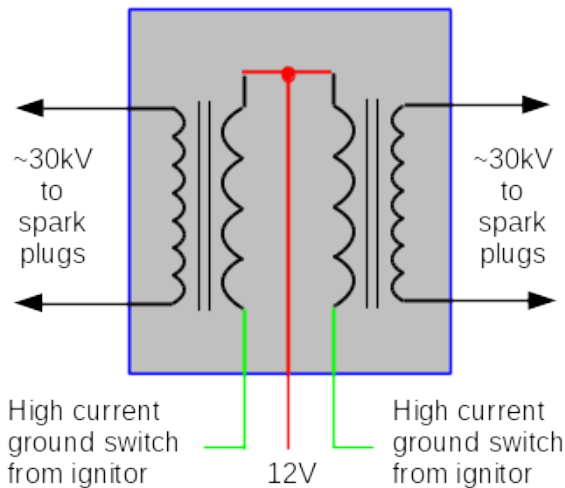

4-tower wasted spark coil-pack such as Ford (EDIS style) Neon, VW and others.

The connections are :

- switched/fused 12V supply
- output from ignitor (left and right)
The resistance measured between 12V and the primary wires will be a few ohms only.

Requires an ignitor or customization for high current outputs.

5.3.5 CDI modules (e.g. MSD, Crane etc.)

Typical CDI units provide a "white wire" trigger input that can be connected to the Megasquirt for ignition control. Follow the manufacturers installation instructions for the other wiring. Ensure that no other trigger inputs are connected (e.g. green, violet.)

The following Ignition settings are required:

Set the Spark Output to "Going High"

Number of coils to "Single Coil"

Dwell to "Standard dwell"

Spark A Output pin as "LED spark"

Q16 should be removed if fitted, 'IGN' is the middle pin of Q16.

MSD is a well known brand and we will cover their wiring scheme here. Other manufacturers use similar wiring colors, but check the supplied diagrams.

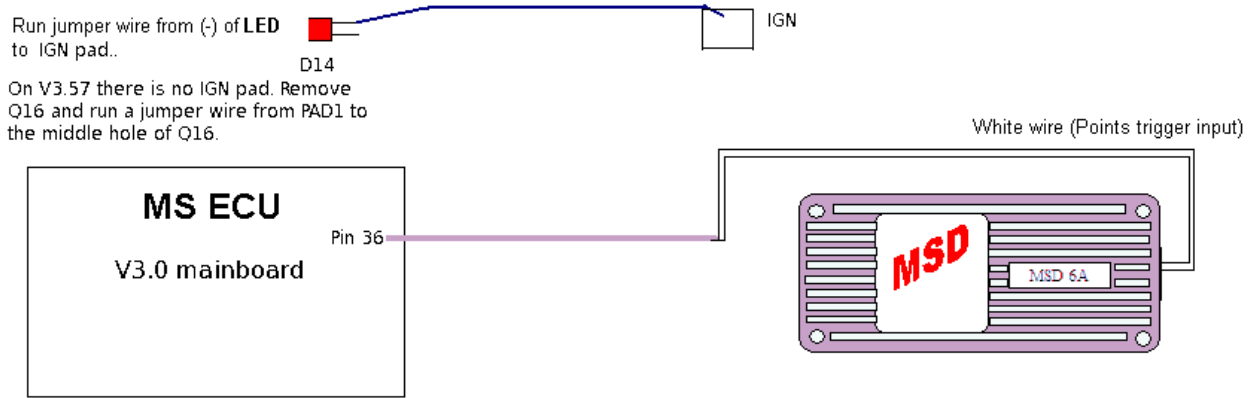

- tach signal is a yellow wire - do not connect this to Megasquirt.
- spark control signal is a white wire - connect this to the Megasquirt.
- ground is a heavy black wire
- permanent 12V power is a heavy red wire
- switched 12 volts is a thin red wire
- the coil positive (+) wire is orange
- the coil negative (-) wire is thin black
- the unused VR signal wires are green and violet.

With the MSD ignition box, we use the white 'points' input wire. Do not connect anything to the green and violet wires. The MSD box is only being used to fire the coil. The Megasquirt must receive its tach input from a crank or distributor pick-up.

5.3.6 Mazda Rotary ignition wiring

Early Mazda rotary engines used a distributor and conventional coils, these are not covered here.

Later engines used EFI and distributorless ignition with a number of specific multiple coil setups. In the tuning software, ensure that the engine stroke is set to "Rotary."

There are three main modes of the Megasquirt rotary ignition support

- FC mode - uses a wasted spark coilpack for leading plugs and individual trailing coils.
External ignitors are used. One for the leading coil and a combination ignitor for the trailing coils.
- FD mode - uses a wasted spark coilpack for leading plugs and individual trailing coils
External ignitors are used. One for the leading coil and one each for the trailing coils.
- RX8 mode - uses one logic coil per plug (four in total)

Mode ->	FC	FD	RX8
Number of coils	Wasted Spark	Wasted Spark	Coil on Plug
Output mode	FC	FD	FD
Spark A	Leading (IGt-L)	Leading	Front Leading
Spark B	Trailing Select (IGs-T)	Front Trailing	Front Trailing
Spark C	Trailing Trigger (IGt-T)	Rear Trailing	Rear Trailing
Spark D	(not used)	(not used)	Rear Leading

Set the Spark Output to Going High. Build circuit in section 5.3.1.3.

The leading coil feeds the upper spark plugs, and trailing the lower plugs. The front (crank pulley end) rotor is considered rotor 1.

Be aware that the output naming in "Output Test Mode Inj/Spk" is slightly different - coil A,B are the leading coils, coil C,D are the trailing coils. Note that this only applies to test mode, physical coil wiring must follow the above table.

Be sure to use the output test mode to confirm coil wiring before attempting a first start.

RX8 logic coils

Pin A = logic signal in

Pin B = power ground

Pin C = 12V supply

5.3.7 Toyota DLI ignition wiring

Some Toyotas use a system named "DLI" that connects between the ECU and the wasted spark coils. This uses a multiplexed signaling system. In the software settings ensure that "Toyota DLI" is selected.

Set the Spark Output to Going High. Build circuit in section 5.3.1.3.

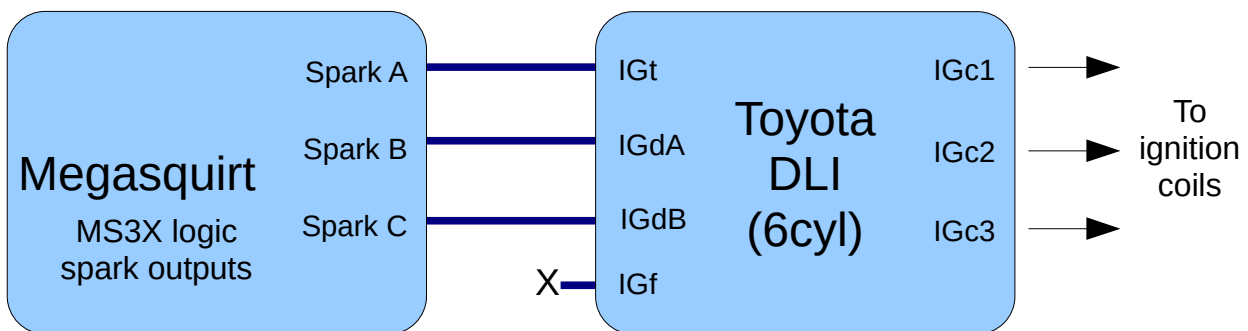

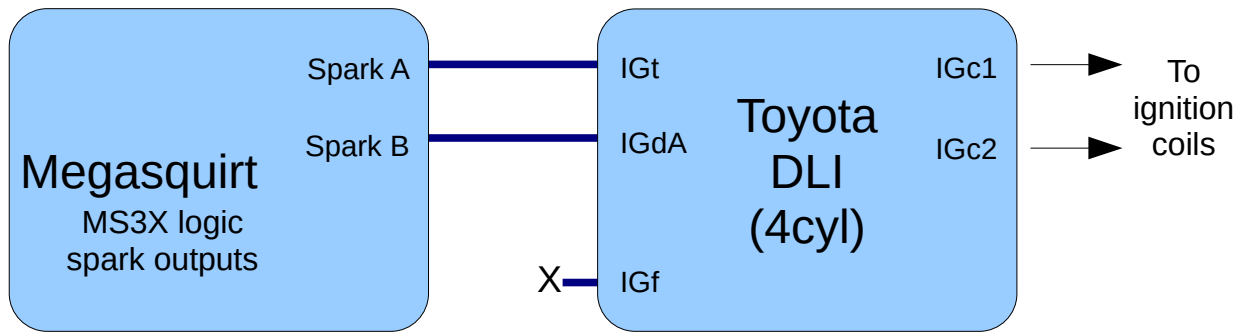

6: Ignition system - specific operating modes

The Megasquirt range supports many different tach input and output schemes including many OEM specific configurations.

For installations on engines without a supported tach input, a 36-1 trigger wheel on the crankshaft is the suggested setup.

Here are all of the 'spark modes' supported by the Megasquirt-3 product range and whether they support wasted spark (W/S) and COP/seq (coil-on-plug or sequential fuel) or not on a 4-stroke engine. 2-stroke engines only need a missing tooth wheel on the crankshaft for sequential fuel and spark.

Note that even if your trigger input could support COP/sequential, your ECU may not have enough outputs.

Spark Mode	Cam input needed ?	W/S ?	COP /seq ?	Applications
Fuel only	N	N	N	Various for fuel only (no spark control)
EDIS	N	Y	N	Early to mid 1990s Fords 4,6,8cyl
Basic trigger (distributor)	N	N	N	Widespread - HEI7, GMDIS, TFI, distributor
Trigger Return	N	N	N	Typically 1980s VW hall distributors
Toothed wheel "Missing tooth wheel" on crank "Missing tooth wheel" on cam "Missing tooth wheel" on crank + single tooth on cam "Dual wheel" non missing on crank + single tooth on cam (36-1, 60-2, 4-1, 24/1, 24/2, 6-1 etc.)	Varies	Varies	Varies	Ford, Bosch ECUs, very widespread. e.g. Ford, BMW, Vauxhall/Opel, many Japanese vehicles using Nippondenso CAS, GM LS2 This is the most common selection covering thousands of installs. See detail pages for all variations
420A/Neon	N	Y	If cam used	420A Neons
36-2+2	N	Y	If cam used	"Next Generation" Crank Chryslers including Jeep.
36-2-2-2	N	Y	If cam used	Some Subaru and Mazda RX8 with stock trigger wheel phasing.
Subaru 6/7	Y	Y	Y	Subarus flat fours
Miata 99-05	Y	Y	Y	1999-2005 Miata with 4 tooth crank trigger and 1,2 cam trigger.
6G72	Y	Y	Y	Mitsubishi 3000GT/Galant
IAW Weber*	Y	Y	Y	Fiat / Cosworth engines with 4 tooth crank trigger and uneven distributor trigger.
CAS 4/1*	Y	Y	Y	Mitsubishi 4G91
4G63	Y	Y	Y	Mitsubishi, Mazda Miata (MX5)
Twin trigger*	(Y)	Y	N	Bike engine with one reluctor and two trigger coils. Typically 4 cylinder wasted-spark.
Chrysler 2.2/2.5*	N	Y	Y	Distributor pickup. YMMV

Spark Mode	Cam input needed ?	W/S ?	COP /seq ?	Applications
Renix 44-2-2	N	N	If cam used	Renault 4cyl, also V6 with 66-2-2-2
Suzuki Swift*	N	N	N	Distributor trigger wheel
Suzuki Vitara 2.0*	N	Y	N	Suzuki Vitara 2.0
Daihatsu 3cyl*	N	N	N	3+1 cam trigger
Daihatsu 4cyl*	N	N	N	4+1 cam trigger
VTR1000*	N	Y	N	12-3 on crank
Rover#1*	N	?	If cam used	Rover K Series 36-1-1
Rover#2*	N	?	If cam used	Rover K Series 36-1-1-1-1
Rover#3*	N	?	If cam used	Rover K Series 36-2-2
GM7X*	N	Y	If cam used	Direct from sensor bypassing GMDIS modules.
QR25DE*	Y	Y	Y	Nissan
Honda RC51*	Y	Y	Y	Also other versiants
Fiat 1.8 16V*	Y	Y	Y	
Optispark	Y	Y	Y	GM LT1 V8 engines
Nissan SR20	Y	Y	Y	Stock high-res trigger disc
Nissan RB25	Y	Y	Y	Stock high-res trigger disc
LS1	N	Y	If cam used	GM LS1, LM7 etc. with 24X crank
YZF1000*	N	Y	N	
Honda Acura	N	Y	If cam used	
VQ35DE*	Y	Y	Y	
Jeep 2000*	Y	Y	Y	
Jeep 2002*	Y	Y	Y	
Zetec VCT	Y	Y	Y	Ford Zetec with 4+1 cam pattern
Flywheel tri-tach*	Y	Y	Y	Audi engines with flywheel tooth sensor
2JZ VVTi*	Y	Y	Y	
Honda TSX/D17	Y	Y	Y	
Mazda6 2.3 VVT*	Y	Y	Y	

Spark Mode	Cam input needed ?	W/S ?	COP /seq ?	Applications
Viper V10	Y	Y	Y	2nd Gen Viper V10
Viper V10 Gen1	Y	Y	Y	1st Gen Viper V10
Honda K24A2	Y	Y	Y	
HD 32-2*	N	N	Y	Harley 45deg V-twin. Can use MAP sensor for phase detection or use a cam sensor.
Miata 36-2*	N	Y	If cam used	Flyin' Miata custom 36-2 wheel fitted to 99-05 engine.
Daihatsu 12+1	(N)	Y	Y	Daihatsu EF-SE engine 3 cyl

* indicates a configuration that has received less usage in the field and may be less well proven. Proceed with caution or discuss with your supplier before using.



Running excessive timing under load will almost always cause severe engine damage such as broken pistons.

It is essential that timing is confirmed with a timing-light on EVERY install.

NOTE! The tach input polarities provided in section 6 are for reference only and subject to review.

6.1 Coil negative for fuel only

For fuel-only installs it is possible to obtain a tach in trigger from the negative terminal of a single coil. Note that this won't work well on a wasted spark setup and must never be connected to a CDI type coil with a high primary voltage.

Coil negative input CANNOT be used for installs using the Megasquirt to control ignition.

Coil negative (not CDI)

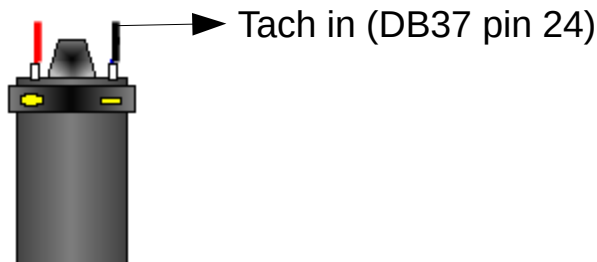

Typical Settings

Spark mode = "Fuel only"

Set mainboard for Optoisolator input as per section 5.2.1

6.2 Distributor pickup

The distributor is the traditional method of timing spark and distributing the high-tension spark voltage to individual spark plugs. Typically this used a set of breaker points, a condenser and a single ignition coil. Most distributors feature mechanical and vacuum advance systems to match spark timing somewhere close to optimal for different operating conditions. Later systems were "breakerless" and replaced the high-maintenance points with VR, hall or optical sensors. When combined with OEM fuel injection systems, the distributor may be "locked" in that there is no advance mechanism - the timing is controlled by the computer. Some OEM systems retain a distributor only for the high-tension spark distribution and use a trigger-wheel arrangement for tach input.

The first step in an install is to identify what kind of system is already fitted to your engine. Usually this is relatively straight forward to establish.

Note that Ford TFI, GMHEI7, GMHEI8 are special cases using a locked distributor and are covered in their own subsections.

6.2.1 Traditional vac/mech distributor

For distributor triggering you need one pulse per spark event. e.g. a normal distributor on a typical 4 stroke, 4 cylinder engine will have four lobes/teeth/vanes/slots in the distributor.

This applies to points, optical, VR, hall.



See section 5.2 for wiring details on the tach input.

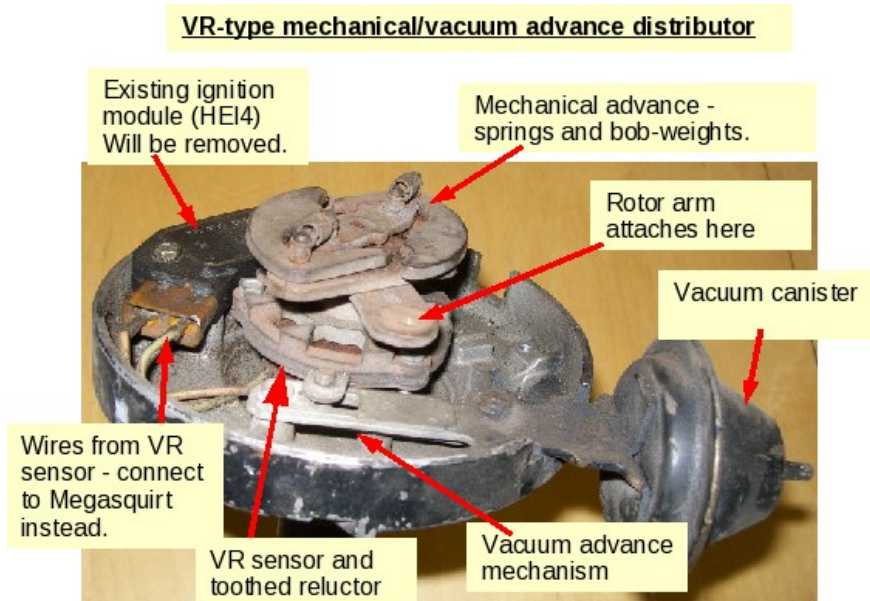

Shown above is a "large cap" General Motors HEI4 distributor, typical on mid 1970s V8s.

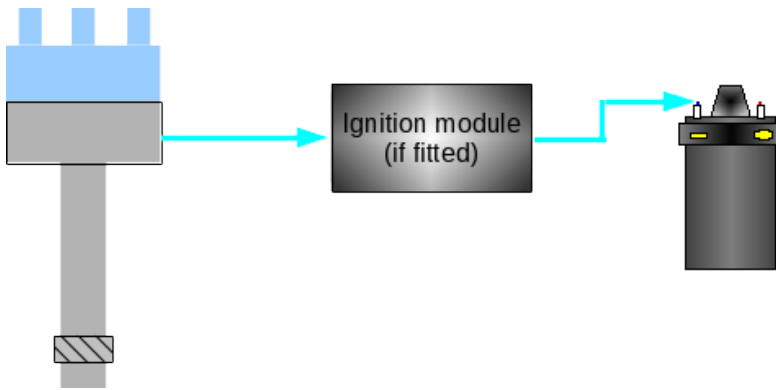

Typical original arrangement

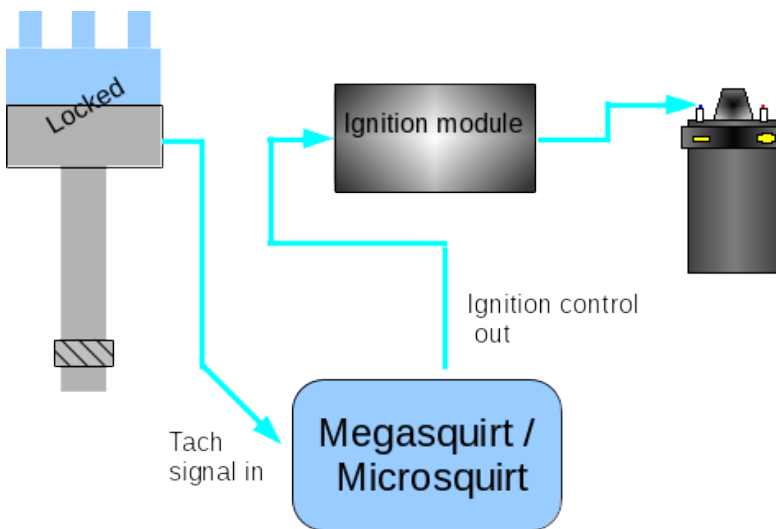

Typical arrangement with ECU ignition timing control and locked distributor

6.2.1.1 Input phasing

A typical distributor includes advance mechanisms which were originally used to control the timing. These are not used when using computer control and must be locked out to give a "locked" distributor.



Correctly modifying an old distributor to give a reliable tach input may well be more difficult than adding a crank trigger wheel and will never be as accurate. You are advised to consider installing a crank trigger wheel (e.g. 36-1) and sensor instead.

Early distributors such as points, HEI4, Duraspark etc, all have advance mechanisms built in. The HEI4 distributor shown above illustrates these mechanisms and is typical of pre-computer distributors. Similar distributors can be converted to computer control-

Remove ignition module (if present)

Connect pickup sensor (VR, hall, opto, points) to ECU.

Remove and weld up mechanical advance mechanism.

Remove vacuum canister.

Use remnants of vacuum advance mechanism to achieve correct input:output phasing.

You may be able to set the rotor output phasing FIRST and then rotate the baseplate to achieve the correct

input phasing.

Later engines may feature a distributor in conjunction with computer controlled timing - usually these distributor are "locked" from the factory and should already have good input and output phasing. (e.g. Ford TFI, GM HEI7/8, Bosch hall effect.) Align as per the factory manuals and determine how it is phased before you modify anything!

The crank angle at which the tach input triggers is of importance and needs to be configured in the Megasquirt. For best spark control there are some optimal and some disallowed crank angles.

A typical engine will have an operating advance range of say 10-50 BTDC timing (depending on engine type.) The trigger must not happen during this range of angles.

It can be really helpful to install timing tape on your crank pulley or temporarily mark on a range of angles.

For best accuracy at high revs or during transients, aim for the trigger to align at 60-90 BTDC. This also allows a full range of timing (including ATDC timing should you need it for boosted conditions.) This range of trigger angle is preferred for new installs.

For slightly better starting, but not quite such good running accuracy, aim for a trigger ~10BTDC or your desired cranking advance. This is the typical trigger angle for TFI and HEI7/8. You cannot retard timing later than the trigger angle. e.g. 9BTDC and lower are not possible with a 10 BTDC trigger angle.

The VR sensor input presents a simple pulse as the reluctor passes the sensor, this gives a timing position easily identified by eye. Use "Basic Trigger"

Rotate the engine to 60 BTDC (or 10 BTDC if chosen) and then align the distributor so the reluctor aligns with the center of the sensor.

VR type distributor pickup

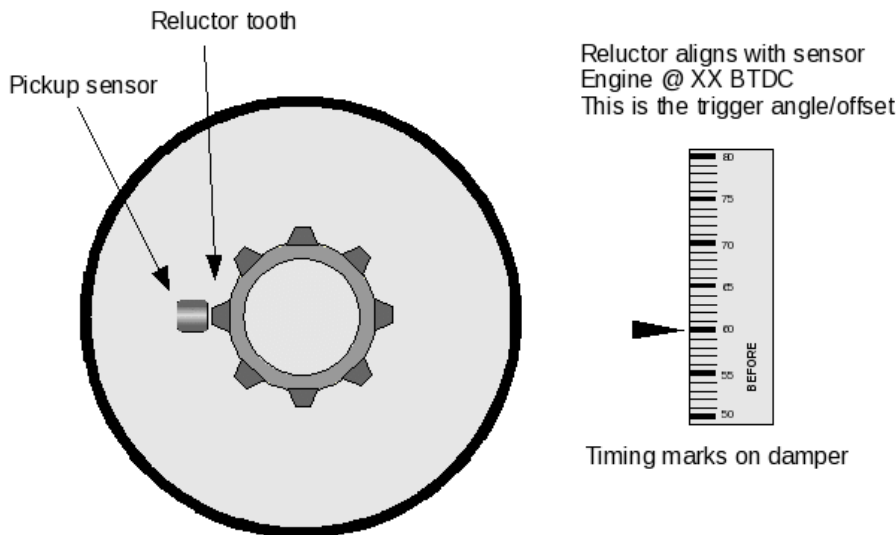

Be aware of the allowable values for "trigger angle". Do not use angles in the disallowed range or you will have unreliable or unexpected operation.

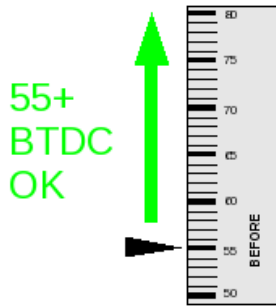

Timing marks on damper

Allowed high angles

Timing allowed in normal range (up to 5 degrees less than trigger angle.) Retarded ATDC timing possible.



Timing marks on damper

Disallowed angles.

Do not use a trigger angle between 16 and 54 degrees.

Timing will not work correctly.

Distributor must be moved or re-phased.

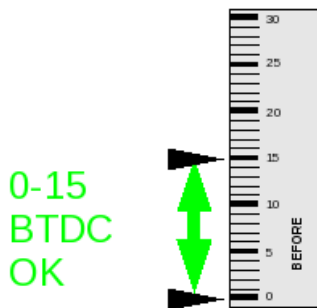

Timing marks on damper

Allowed low angles

Timing allowed in normal range (greater than trigger angle.) Retarded ATDC timing not possible.

Once the tach input is setup it is important to confirm the output phasing is correct.

6.2.2 Rotor / Output phasing - all distributor installs



Rotor phasing is CRITICAL.

Without it you will get cross firing and the engine will run extremely badly.

Rotate your engine to ~25 BTDC.

The rotor arm MUST point towards a tower on the distributor.

Distributor rotor phasing

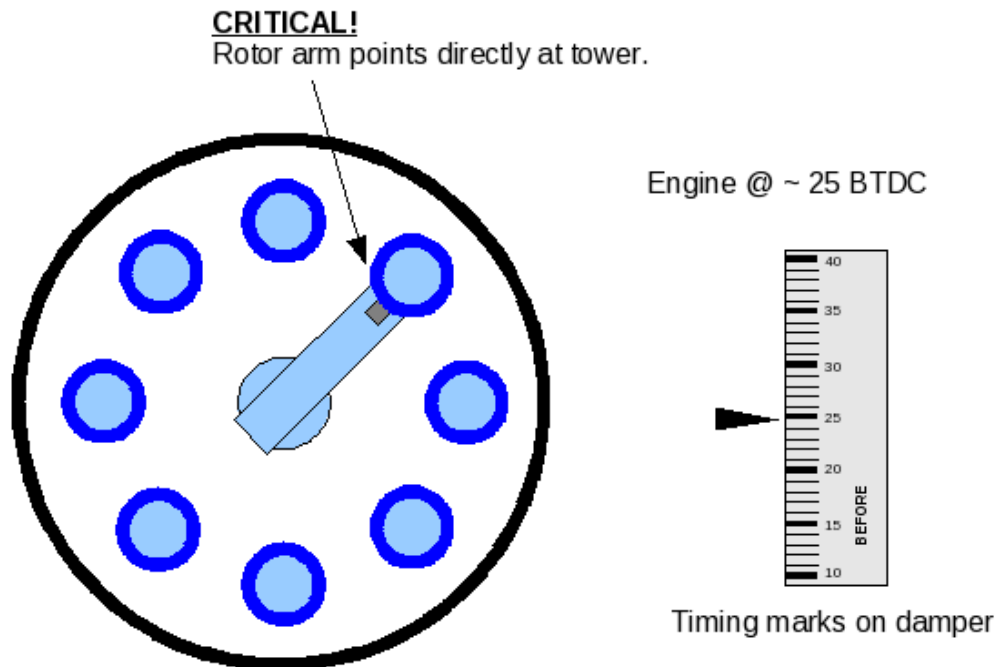

When using the distributor for the tach input as well, beware of just rotating the distributor - that would change the input phasing that you already set - you may need to make a physical modification to rotate the rotor arm. (e.g. weld up the locating slot and cut a new one.) If you moved the distributor, go back and re-set the input phasing.

This potential conflict between input and output phasing is why a crank trigger is strongly recommended.

If you are crank triggering and the distributor is only used for the spark distribution then you can simply rotate the dizzy to achieve the required rotor phasing. In this case it is not necessary to 'lock' the distributor, you can unhook the vacuum canister and leave the mechanical advance operational.

6.2.3 Distributor with hall/optical 'trigger return'

The purpose of the "Trigger Return" mode is to have accurate cranking timing as well as accurate running timing. It achieves this by using the signal from both edges of a vane/slot. One edge is used for the timing calculations during running and will typically pass the sensor at 55BTDC or more. The other edge is used for cranking timing and must pass the sensor at the desired cranking advance angle e.g. 10BTDC

This scheme was commonly used by VW during the 1980s with a locked hall-effect distributor.



'Trigger return' may only be used if the slots/shutters/vanes in the distributor are evenly spaced and equal sized.

Do not try to use 'trigger return' with many Nissan optical pickups or with signature-PIP TFI as these have uneven slots/vanes.



See section 5.2 for wiring details on the tach input.

Configuring trigger return requires knowing the crank angle that each vane edge passes the sensor. You can check this visually or by wiring up the system and using a multimeter to measure the output from the sensor.

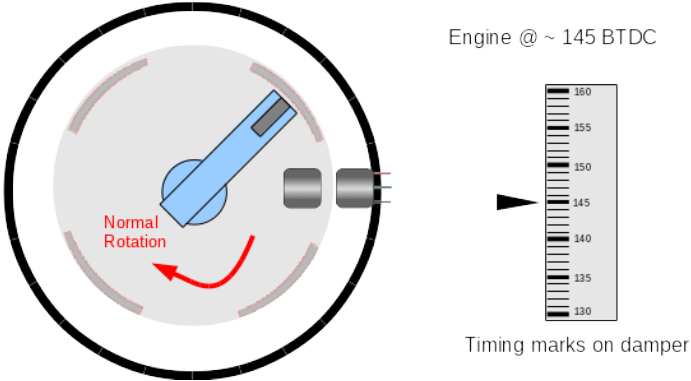
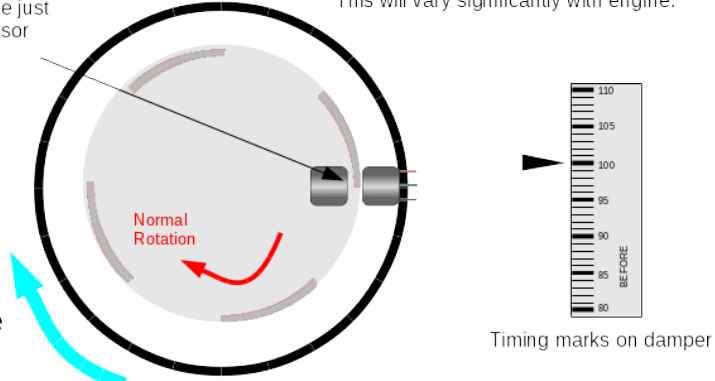
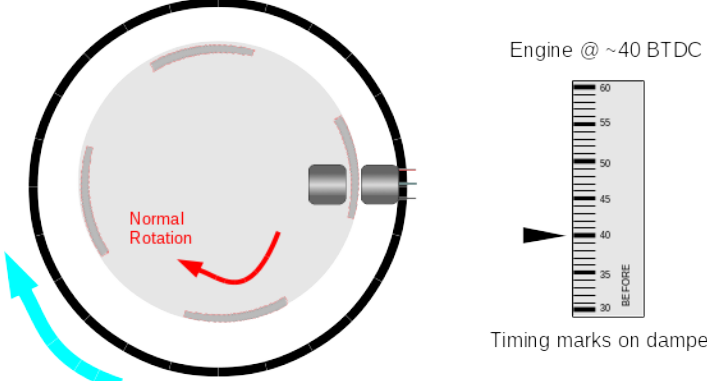
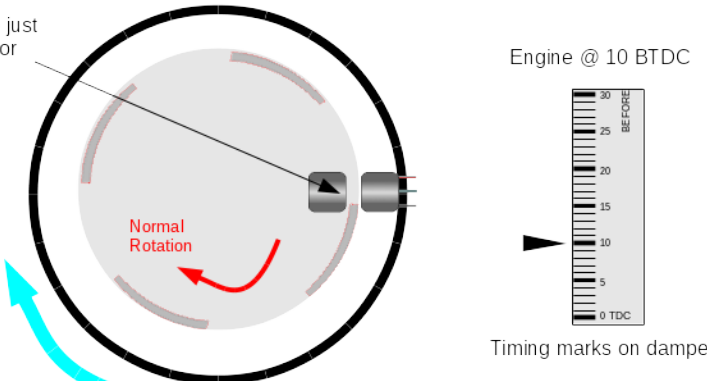
<p>A. Hall/opto distributor showing inactive trigger.</p>	 <p>Engine @ ~ 145 BTDC</p> <p>Timing marks on damper</p>
<p>B. Engine rotated forwards until edge at sensor. The crank angle here is the "Trigger Angle"</p>	 <p>Leading edge just blocking sensor</p> <p>Normal Rotation</p> <p>Turn engine forwards</p> <p>Timing marks on damper</p> <p>Note! These examples are drawn with - a leading edge of 100 BTDC - a trailing edge of 10 BTDC. This will vary significantly with engine.</p>
<p>C. Engine turned forwards some more.</p>	 <p>Normal Rotation</p> <p>Turn engine forwards</p> <p>Engine @ ~40 BTDC</p> <p>Timing marks on damper</p>
<p>D. Engine turned forwards some more.</p> <p>This is the Return angle and needs to match your setting for cranking advance. This needs to be ~10BTDC.</p> <p>Rotate your distributor if needed, then repeat steps B,C,D.</p>	 <p>Trailing edge just clear of sensor</p> <p>Normal Rotation</p> <p>Turn engine forwards</p> <p>Engine @ 10 BTDC</p> <p>Timing marks on damper</p>

The output phasing on an OEM trigger-return type distributor installed in the normal position should not require adjustment.

Trigger-return can also be used with a latching hall sensor and pairs of magnets on a crank trigger. One pole (e.g. N) triggers and latches the sensor and the other pole (e.g. S) un-latches the sensor. This could be of particular use on single cylinder engines to gain accurate cranking and running timing. In this case no distributor is used and a single coil is connected directly to the spark plug.

6.2.4 Distributor with basic crank trigger

Installing a "flying magnet" crank trigger gives more accurate ignition control than using a distributor based pickup as it eliminates timing chain and cam-gear slop. It also eliminates the hassle of re-phasing the distributor.

For best timing accuracy, it is recommended that the flying magnet passes the pickup sensor when the engine is around 60BTDC.



See section 5.2 for wiring details on the tach input.

Typical Settings

Spark mode = "Basic Trigger"

Trigger angle/offset = 60 BTDC (adjust as required)

Ignition capture = Set according to whichever edge gives the most stable signal. (If timing advances with RPM, try flipping it.)

Spark output = depends

Spark A output pin = depends

Dwell type = depends

Dwell duty = depends

6.2.5 Distributor with crank trigger wheel



This is the preferred method to use with a distributor.

Using a trigger wheel (e.g. 36-1) on the crank is the most best way to obtain accurate ignition control. The ECU uses every tooth on the wheel to determine engine position. It eliminates timing chain and cam-gear slop. It also eliminates the hassle of re-phasing the distributor.

The distributor and single coil can be retained, but you have the option of a future upgrade path to wasted-spark or perhaps coil-on-plug ignition.

The setup and configuration of the crank trigger wheel is covered in the Toothed wheel section 6.9.

6.3 Ford TFI

Ford's TFI module was used throughout the 1980s and into the 1990s on many millions of vehicles in two main mounting positions - 'distributor mount' and 'remote mount'. There are also two electrical versions: "Push Start" and "Computer Controlled Dwell". Checking the wiring on pin4 is likely best. The wiring of the modules is largely the same, just the distributor mount connects directly to a 3 wire hall sensor in the distributor. In most installations you do not need to concern yourself with that as only the 'PIP' and 'SPOUT' connections are of interest. The other connections should be left stock.

Push-Start (PS) vs. Computer Controlled Dwell (CCD)

The module described mainly here is the 'PS' type that uses a 12V start signal, it is claimed to be gray in color. 50% dwell duty should be used.

The 'CCD' type is claimed to be black in color. and pin 4 runs as a diagnostic signal to the original ECU. These modules need standard dwell control e.g. 3ms instead of a fixed duty. Other wiring should be the same.

Base Timing and phasing

"Base Timing" on the distributor (with computer control 'SPOUT' disconnected) is around 10BTDC. This is the number you should use as your initial Trigger Offset. As these distributors were designed for ECU control, the rotor arm phasing should already be correct.

Signature PIP

Note that there is a TFI variant with "Signature PIP" that in the original install allows for cylinder identification and sequential fuel. Spark trim and multiple spark outputs are not supported.

These distributors should be configured as "Basic Trigger".

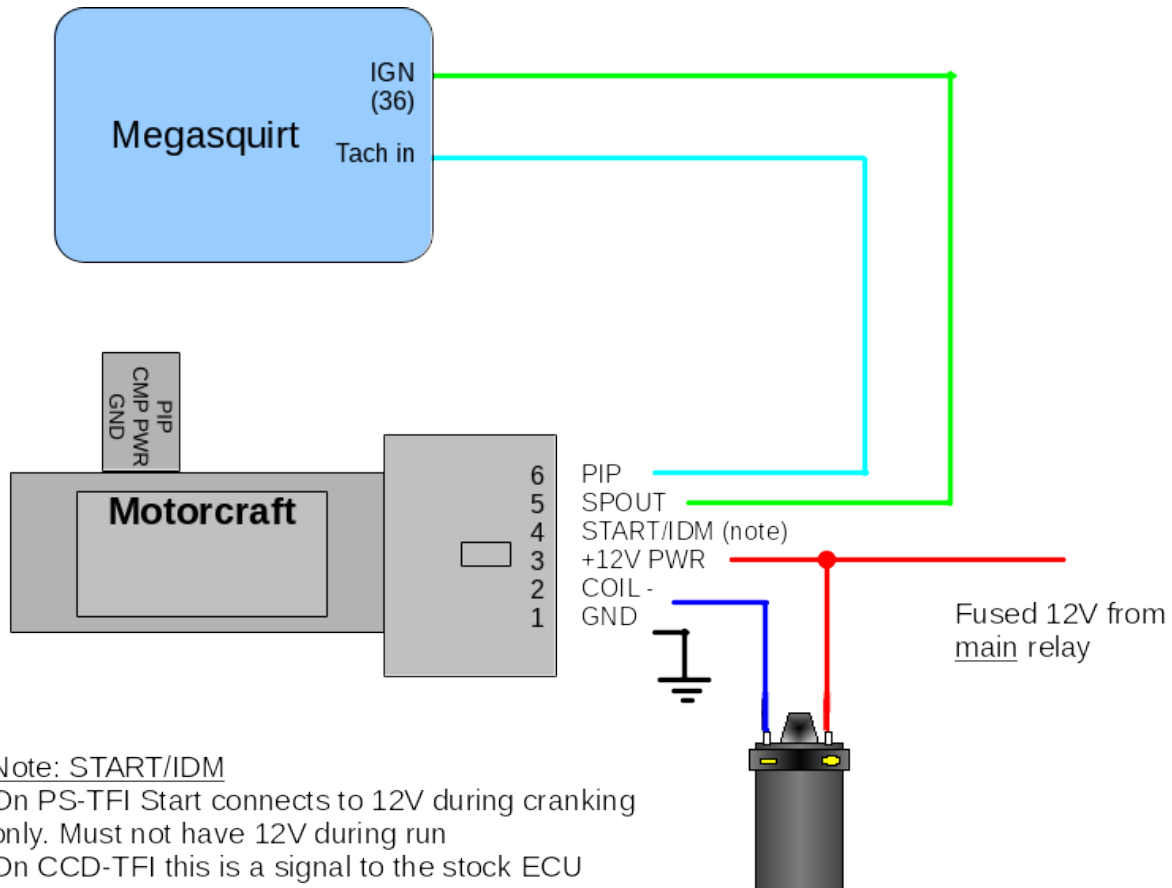

Set the mainboard as per section 5.2.4

Make the following modifications:

- a) Solder two wires to a 330R resistor and heatshrink.
- b) Solder one of the wires to CPU pin 7 on the underside of the board.
- c) Solder the other wire to IGBTin.
- d) Ensure Q16 is fitted
- e) Solder two wires to a 1k resistor and heatshrink.
- f) Solder one of the wires to S12 (near the DB37 connector.)
- g) Solder the other wire to the middle pin of Q16.

Typical Settings

Spark mode = "Basic Trigger"

Trigger angle/offset = 10 BTDC as a starting point, fine tune with a timing light.

Ignition capture = "Falling edge"

Spark output = "Going High"

Spark A output pin = "LEDs spark"

Dwell type = "Fixed duty"

Dwell duty = "50%"

6.4 GM HEI7

The original "High Energy Ignition" (HEI) distributors used the 4 pin module from the early 1970s is fine in the breakerless distributor as designed, but is not suitable for computer timing control. The later 7 and 8 pin modules and corresponding distributors are designed for computer control and should be an easy swap onto earlier engines - not only are those modules intended for computer control, but their distributors are already locked-out so no modifications are required. HEI7/8 uses three control wires to/from the Megasquirt.

The 'Ref' signal from the module to the Megasquirt gives rpm and engine position information.

The 'Est' signal from Megasquirt to the module controls the advance when running.

The 'Bypass' signal from Megasquirt to the module allows the module to beneficially control its own advance during cranking. Once the engine has been running for more than 5 seconds, the Megasquirt takes control of timing.

P = Positive from VR sensor

N = Negative from VR sensor

E = Electronic spark timing (EST) from Megasquirt IGN

R = Reference (REF) to Megasquirt Tach in

B = Bypass from Megasquirt bypass output (SPR3 shown)

Set the mainboard as per section 5.2.4

Make the following modifications:

- a) Ensure that Q16 is not fitted.
- b) Run a jumper wire from PAD1 to the middle pin of Q16.
- c) Run a jumper wire from PAD3 to SPR3. (This is the bypass output.)

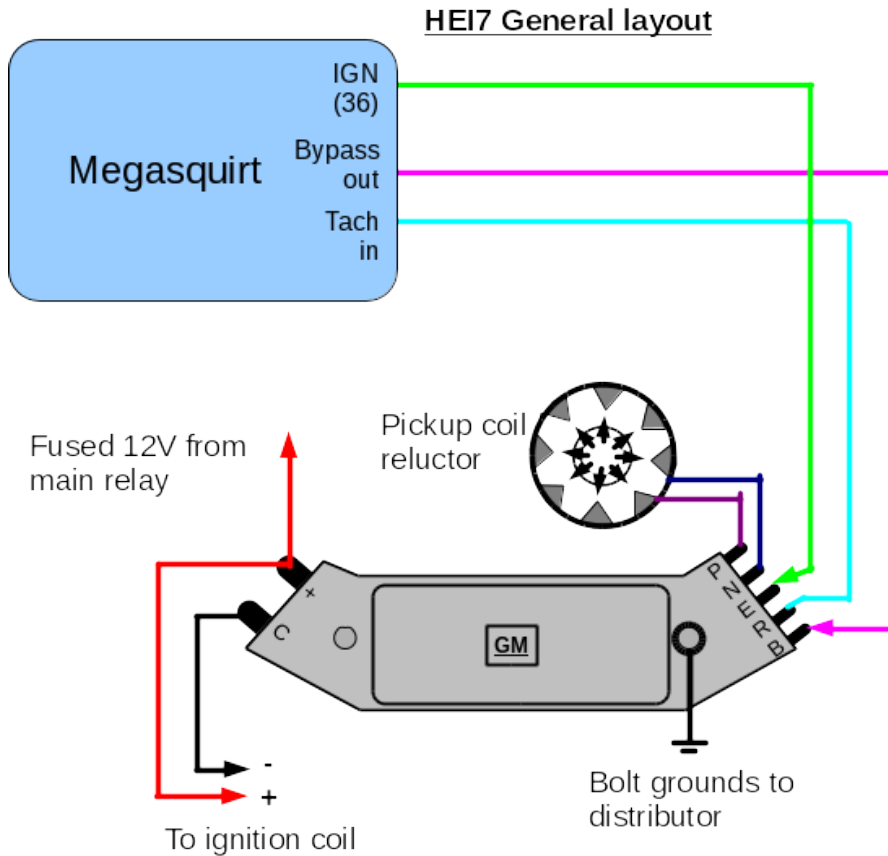

Typical Settings

- Spark mode = "Basic Trigger"
- Ignition capture = "Rising Edge"
- Spark output = "Going Low"
- Spark A output pin = "LEDs spark"
- Dwell type = "Standard Dwell"
- Nominal Dwell = "3.0"
- GM/HEI options = "GM bypass"

6.5 GM HEI8

This works the same as HEI7, but the module is packaged differently.

The same board configuration is required as for HEI7 in section 6.4

- P = Positive from VR sensor
- N = Negative from VR sensor
- G = Ground to Megasquirt Sensor ground
- B = Bypass from Megasquirt bypass output (SPR3 shown)
- R = Reference (REF) to Megasquirt Tach in
- E = Electronic spark timing (EST) from Megasquirt IGN

HEI8 General layout

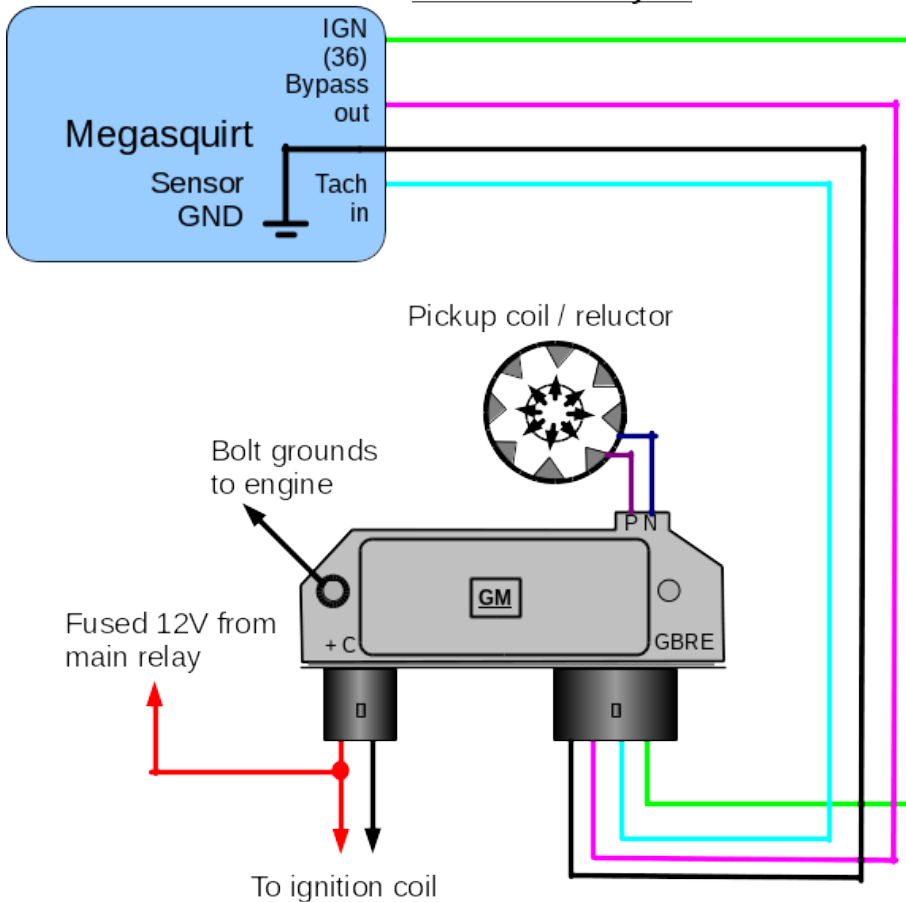

Typical Settings

- Spark mode = "Basic Trigger"
- Ignition capture = "Rising Edge"
- Spark output = "Going Low"
- Spark A output pin = "LEDs spark"
- Dwell type = "Standard Dwell"
- Nominal Dwell = "3.0"
- GM/HEI options = "GM bypass"

6.6 Dual Sync Distributor

A dual-sync distributor is an aftermarket locked distributor that provides a clean trigger signal for an ECU. The signal can be used for sequential fuel and spark.

Setting the rotor arm phasing is important as shown in section 6.2.2.

It is possible to use both signals from the dual-sync distributor and control a distributorless ignition system (wasted spark or wasted-COP.) Use the "Dual wheel" option in the Trigger Wheel system. Set the rotor arm phasing, then determine the tooth#1 angle from the Trigger Wheel page.

Alternative: It is possible to ignore the "reference" signal from the distributor and configure as a regular distributor using "Basic Trigger." This will allow batch fire fuel only.

6.7 Ford EDIS



Ford's Electronic Distributorless Ignition System (EDIS) is an ignition system that does not require a cam position signal. It requires a variable reluctor (VR) sensor and a 36-1 tooth crank wheel (36-1 means '36 teeth minus one', and refers to 36 evenly spaced teeth, one of which has been removed), it will not work with other pattern wheels or hall sensors.

EDIS is a particularly easy way to install programmable ignition control on an older engine with a distributor. The EDIS modules are very reliable and the system works well. The EDIS module itself handles all the decoding of the toothed wheel and sends one pulse per cylinder to the ECU.

It is strongly advised to use Ford VR sensors and Ford coilpacks with the EDIS modules. They were designed to work together and do.

Note! If your engine already has a different supported trigger wheel setup, consider utilizing that before retrofitting EDIS.

6.7.1 System components

The EDIS system is made up of:

- EDIS module,
- crank wheel,
- crank variable reluctor (VR) sensor and
- one or more coil pack(s).

See appendix B for a junk-yard hunters guide to finding EDIS.

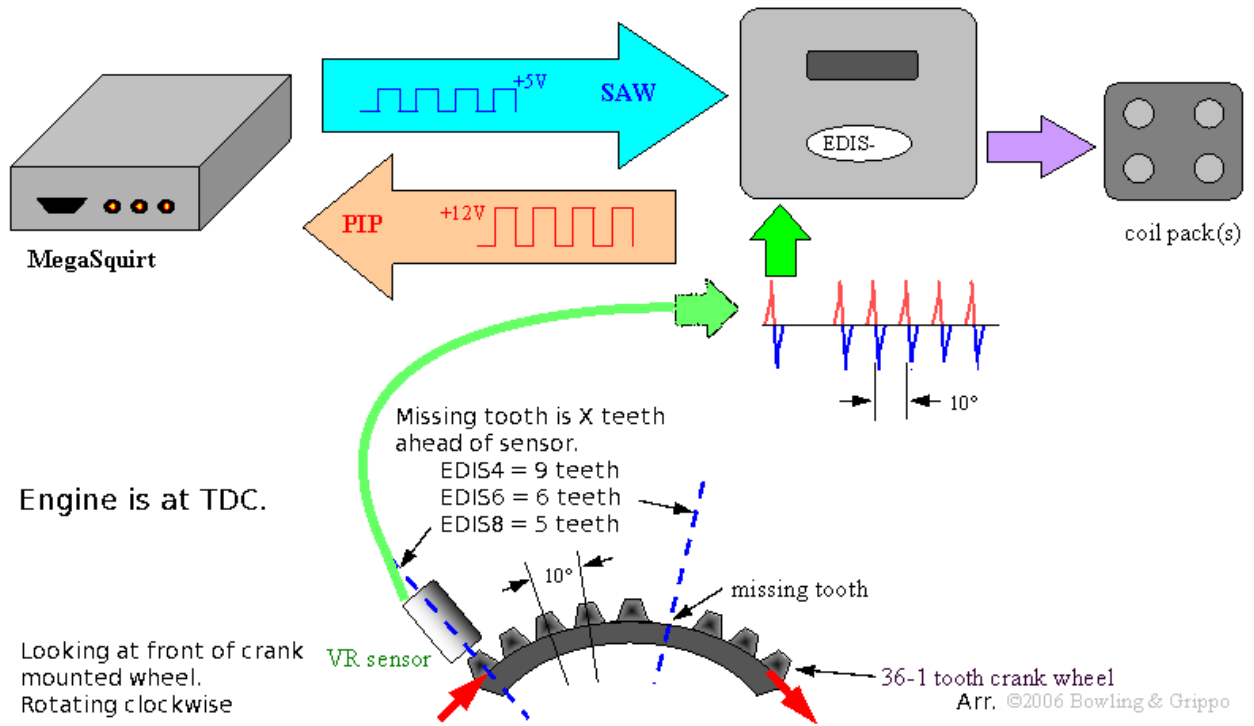

6.7.2 ECU wiring

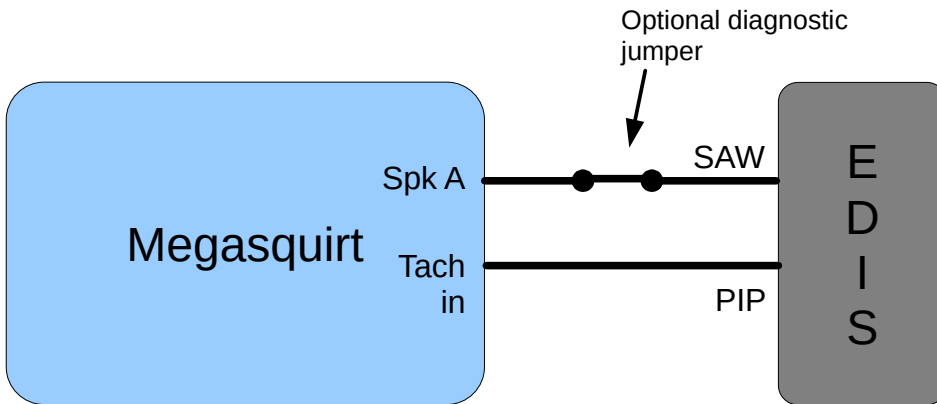

Set the mainboard as per section 5.2.4.

The following internal modifications are required:

- a) Ensure that Q16 is not fitted.
- b) Run a jumper wire from JS10 to the middle pin of Q16

Typical Settings

Spark mode = "EDIS"

Ignition capture = "Rising Edge"

Spark output = "Going High"

Spark A output pin = "JS10"

6.7.3 Module wiring

The EDIS system comes in three varieties : EDIS4, EDIS6, EDIS8 which are suited to even-fire 4, 6, 8 cylinder engines. The specific wiring of the module varies slightly between the variants.

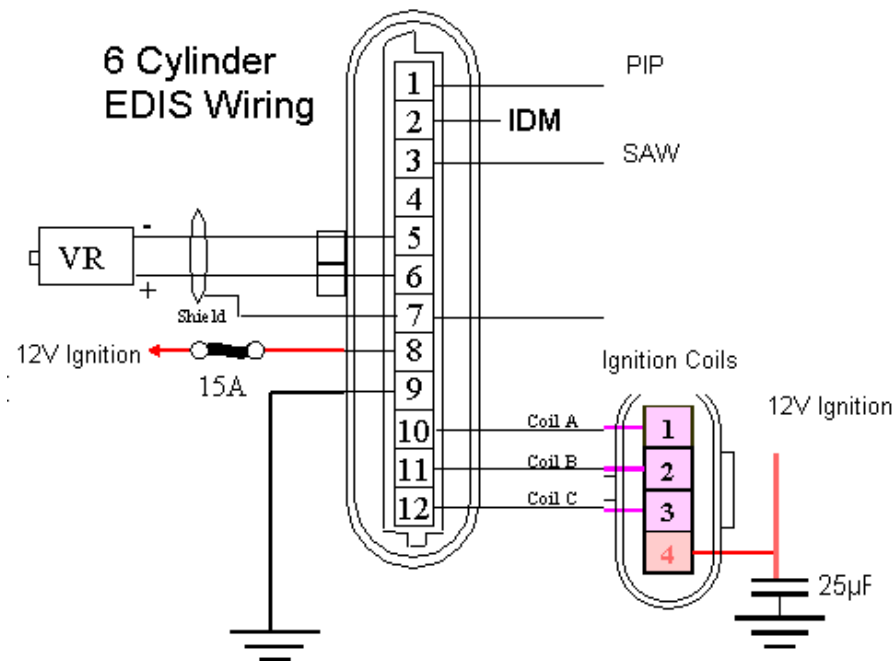
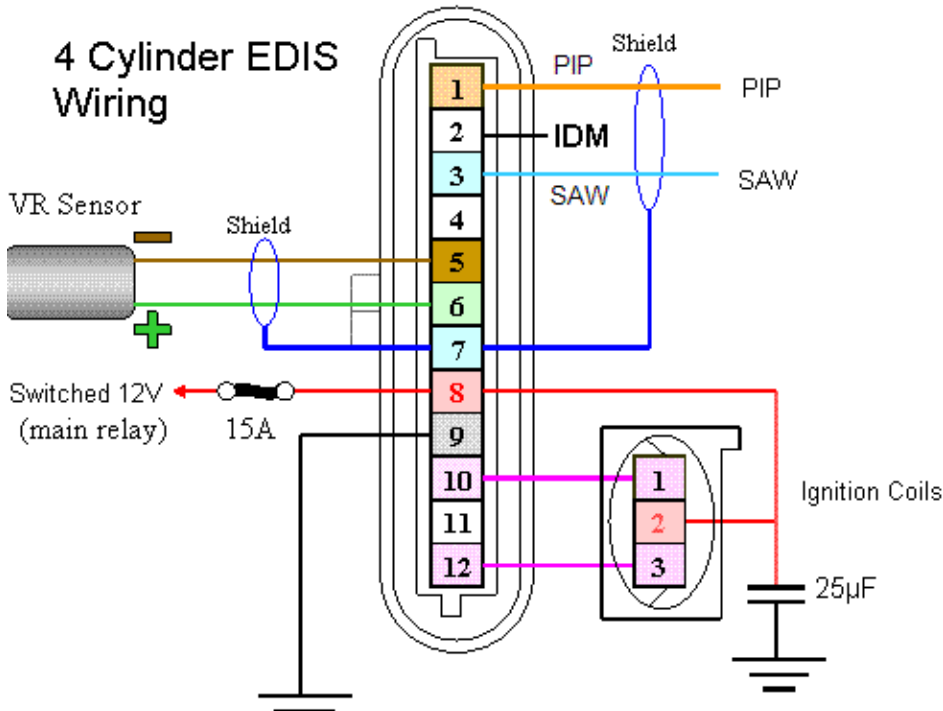

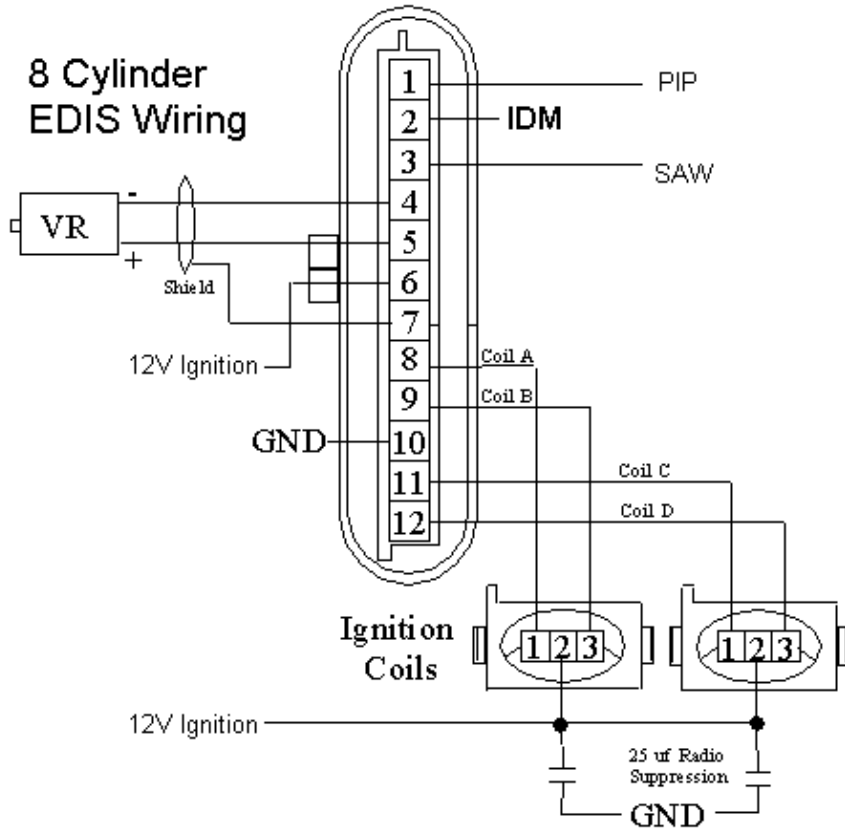

6.7.4 36-1 trigger wheel and VR sensor

The relationship of the VR sensor and the missing tooth is critical. The EDIS module expects and requires a specific phasing.

On engines originally equipped with EDIS this will already be set. Later Ford engines also maintain the same phasing even though the EDIS function is now built into the ECU.

Note that while the relationship of the VR sensor and the missing tooth is critical, the actual placement of the VR sensor on your engine is not. i.e. the VR sensor could be at 12 o'clock, 3 o'clock, 6 o'clock, 9 o'clock - it really does not matter - so long as the wheel is phased to match.

See the diagrams below EDIS4, EDIS6, EDIS8. The main diagrams show clockwise engine rotation as that is the most common, there is an anti-clockwise example afterwards.

For each module type there are two phasing diagrams shown.

Both methods achieve the same result.

- method a - engine is set to TDC and teeth counted
- method b - engine is set to angle X BTDC and missing tooth aligned with sensor

Use method 'a' if you can. Alternatively, some installers may find method b easier to understand.

6.7.4.1 EDIS4 - Clockwise rotation (normal) - method a

Set your engine at TDC, then put the missing tooth 9 teeth earlier (more clockwise) than the sensor. This will put the center of a tooth central to the sensor.

EDIS4 - 9 teeth offset

With engine at TDC, the VR sensor aligns with the 9th tooth

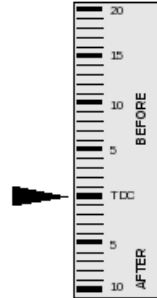
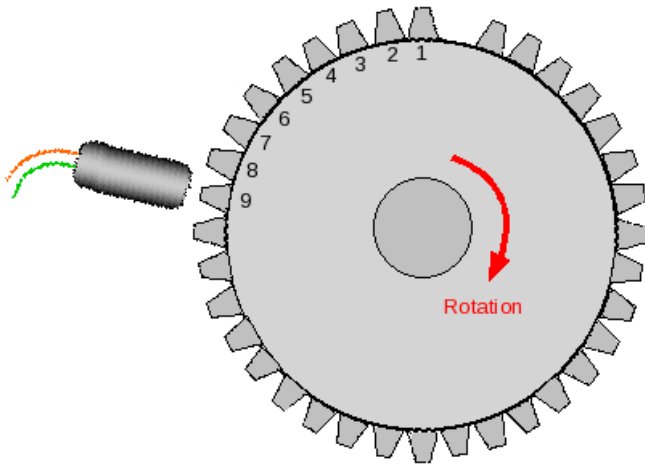

Timing marks on damper

Clockwise rotation

6.7.4.2 EDIS4 - Clockwise rotation (normal) - method b

Turn your engine to 90 BTDC. Mount the VR sensor wherever is convenient and mount trigger disc so that the center of the sensor aligns with the center of the missing tooth.

EDIS4

This shows another view of the **same** sensor to missing-tooth alignment. When the missing tooth is lined up with the sensor the engine is at 90 BTDC

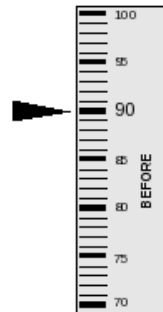
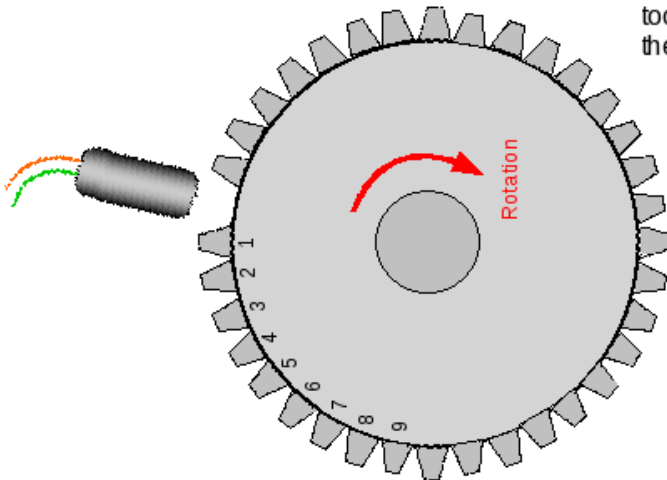

Timing marks on damper

Clockwise rotation

6.7.4.3 EDIS6 - Clockwise rotation (normal) - method a

Set your engine at TDC, then put the missing tooth 6 teeth earlier (more clockwise) than the sensor. This will put the center of a tooth central to the sensor.

EDIS6 - 6 teeth offset

With engine at TDC, the VR sensor aligns with the 6th tooth

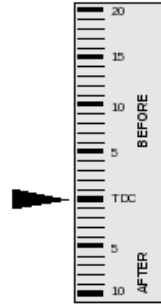
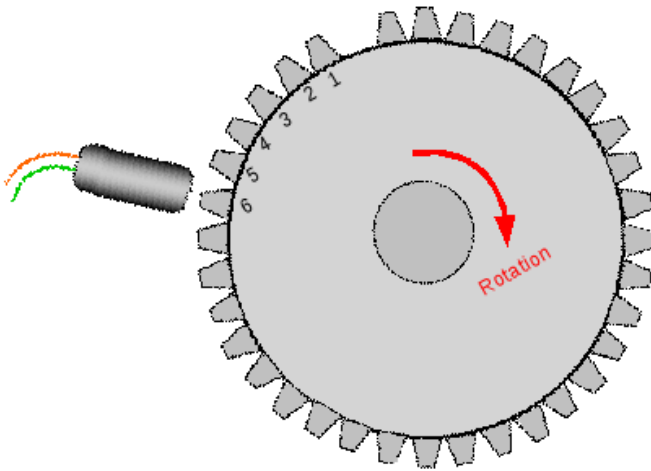

Timing marks on damper

Clockwise rotation

6.7.4.4 EDIS6 - Clockwise rotation (normal) - method b

A different way of looking at the SAME phasing.

Turn your engine to 60 BTDC. Mount the VR sensor wherever is convenient and mount trigger disc so that the center of the sensor aligns with the center of the missing tooth.

EDIS6

This shows another view of the **same** sensor to missing-tooth alignment. When the missing tooth is lined up with the sensor the engine is at 60 BTDC

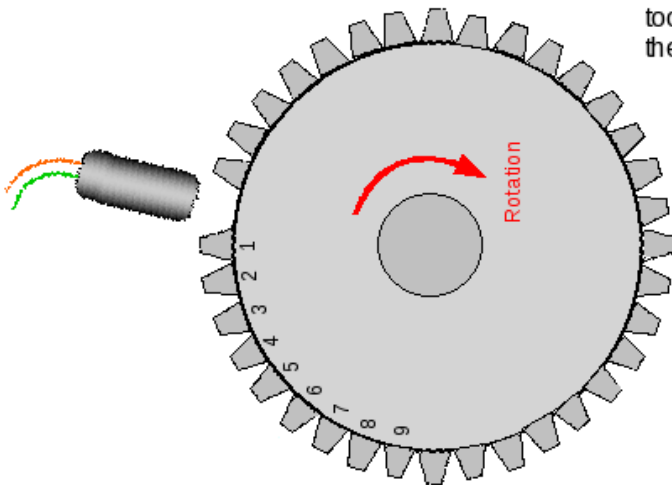

Timing marks on damper

Clockwise rotation

6.7.4.5 EDIS8 - Clockwise rotation (normal) - method a

Set your engine at TDC, then put the missing tooth 5 teeth earlier (more clockwise) than the sensor. This will put the center of a tooth central to the sensor.

EDIS8 - 5 teeth offset

With engine at TDC, the VR sensor aligns with the 5th tooth

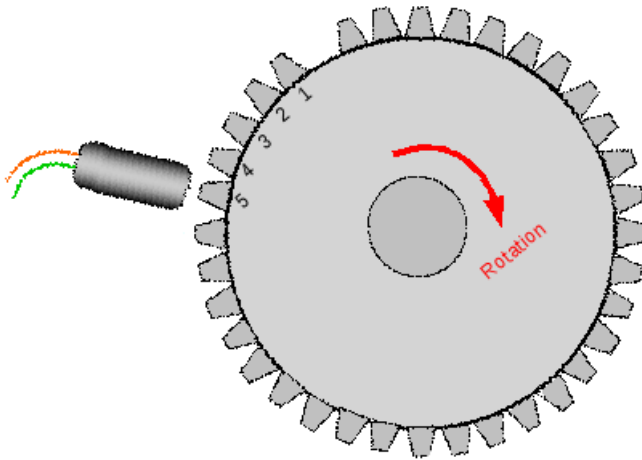

Timing marks on damper

Clockwise rotation

6.7.4.6 EDIS8 - Clockwise rotation (normal) - method b

Turn your engine to 50 BTDC. Mount the VR sensor wherever is convenient and mount trigger disc so that the center of the sensor aligns with the center of the missing tooth.

EDIS8

This shows another view of the **same** sensor to missing-tooth alignment. When the missing tooth is lined up with the sensor the engine is at 50 BTDC

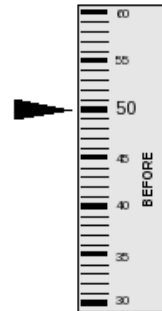
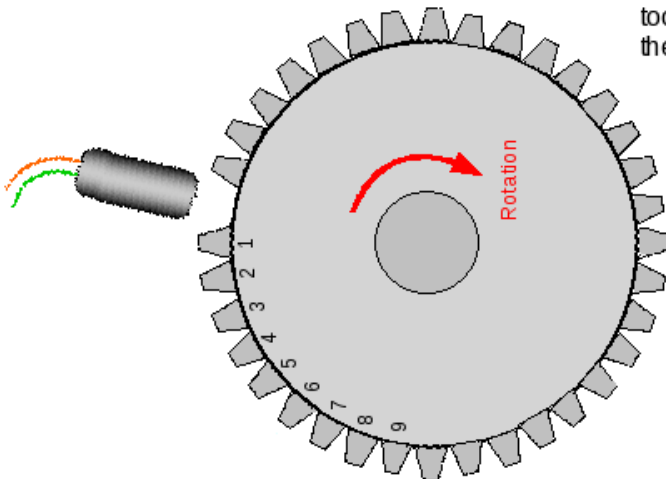

Timing marks on damper

Clockwise rotation

6.7.4.7 EDIS4 anti-clockwise

Anti-clockwise rotation.

The same applies, but directions are reversed.

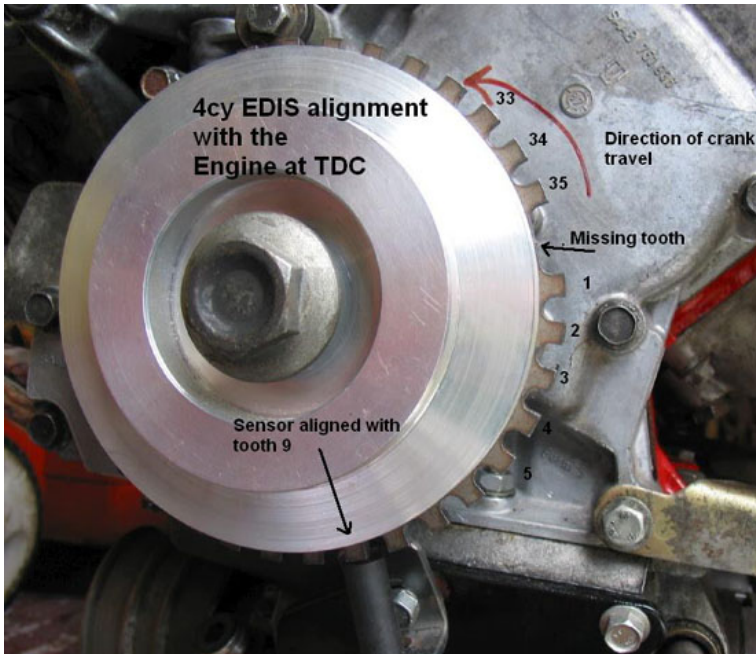

6.7.5 Checking the timing

As with all installs, it is important to confirm the timing is correct. To test this it is best to first run the EDIS in limp home mode. This can be achieved by disconnecting the SAW plug/socket or switching off/unplugging the ECU. Fit your strobe onto no.1 plug lead as normal (you may need to try the other tower of the pair).

A dumb strobe is advised, or use a strobe that is compatible with wasted-spark or 2-stroke.

Ensure EDIS still has power and crank your engine, check that the timing is exactly 10deg. If not, adjust your sensor until it is. It is safe to idle the engine with the SAW lead disconnected, timing should be rock solid at 10BTDC. Don't forget to reconnect the plug when done!

Now that you have confirmed that the EDIS is correctly running at 10BTDC base timing, you need to check that ECU is correctly commanding timing on the EDIS.

Start the engine and then on the Ignition settings menu on your tuning computer, select "Fixed Timing" and enter 15 BTDC, check that you strobe 15 BTDC on the crank.

When done, return the setting to "Use table" and Burn.

6.8 GM DIS (for reference only)

As far as the ECU is concerned, GMDIS works similarly to HEI7. Even though the module is controlling wasted spark ignition, the ECU does not receive any cylinder identification or phase information.

The same internal modifications are required as for HEI7 in section 6.4

This wiring need confirming.

P = Positive from VR sensor

N = Negative from VR sensor

G = Ground to Megasquirt Sensor ground

B = Bypass from Megasquirt SPR3

R = Reference (REF) to Megasquirt Tach in.

E = Electronic spark timing (EST) from Megasquirt IGN (36)

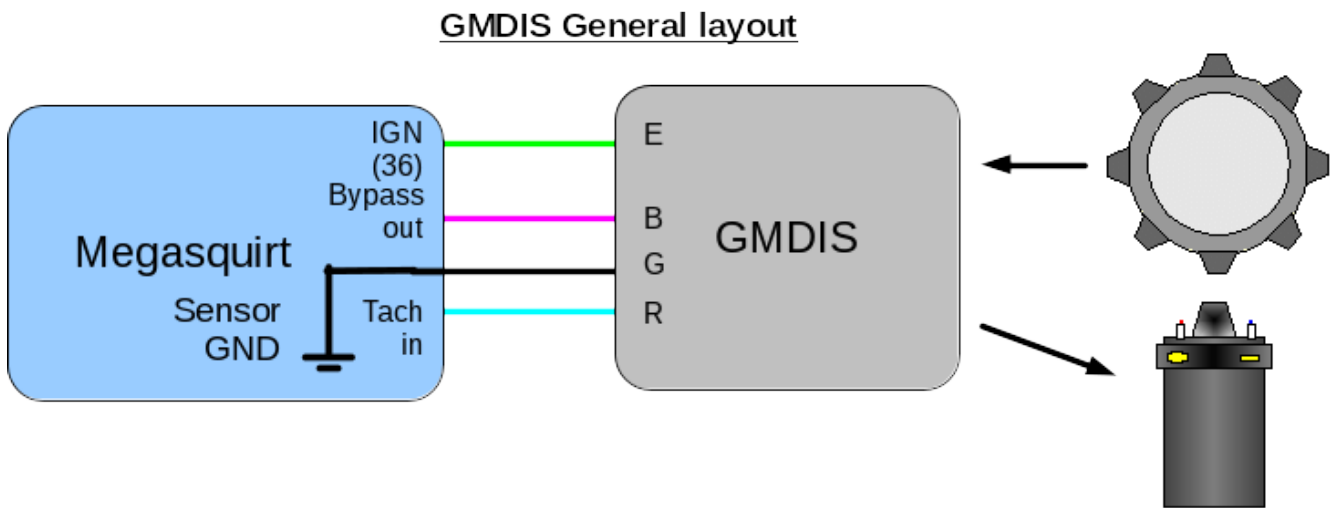

These settings need confirming.

Ignition capture = "Falling" (check!)

Spark output = "Going High" (check!)

Spark A output pin = "LED spark"

Dwell type = "Standard Dwell"

Nominal Dwell = "3.0"

GM/HEI options = "GM bypass"

6.9 Toothed Wheel

The Toothed Wheel mode is designed to support most combinations of regular missing tooth wheels with or without a cam signal. It is the most commonly used "spark mode" for tach input.

Various spark outputs (single coil, wasted spark, coil-on-plug) are supported by Toothed Wheel, the table in section 6.9.1 shows possible options. See section 5.3 for ignitor, coil and wiring examples.

Other irregular OEM specific wheel patterns (e.g. 420A, 4G63, LS1) have their own spark modes which are covered in later sections.

6.9.1 Wheel combinations

The table below lists all of the valid combinations for trigger wheel. However some of the modes will rarely be used. The most common are:

36-1 on crank - many Fords

36-1 on crank plus single tooth cam sensor - same

60-2 on crank - many vehicles with Bosch ECU, BMW, VW, Audi, Volvo, Vauxhall, Opel, Peugeot etc.

60-2 on crank plus single tooth cam sensor - same

24 tooth on cam - many Japanese originated vehicles use the Nippondenso 24 tooth CAS with differing numbers of 2nd trigger teeth and sensors.

Note - this table is for four-stroke piston engines. Two stroke or rotaries only need 360 degrees of information for full sequential and COP.

Commonly used modes have detailed sections on how to set them up. Unusual modes are not documented in detail at this time.

Physical wheels		Supports							Settings		
Main wheel	Secondary wheel	Single coil	Wasted spark	Wasted-COP	COP	Batch/bank fire	Semi-seq	Seq.	Trigger wheel arrangement	Main wheel speed	2nd trig every rotation of
Missing tooth on crank	None	Y	Y	Y	N	Y	Y	N	Single wheel with missing tooth	Crank	n/a
Missing tooth on cam	None	Y	Y	Y	Y	Y	Y	Y	Single wheel with missing tooth	Cam	n/a
Missing tooth on crank	Single tooth on cam	Y	Y	Y	Y	Y	Y	Y	Dual wheel with missing tooth	Crank	n/a
Missing tooth on crank	LS2 4X, VW 2 wide/narrow or half-moon on cam	Y	Y	Y	Y	Y	Y	Y	Dual wheel with missing tooth	Crank	n/a
Non-missing tooth on crank	Single tooth on crank	Y	Y	Y	N	Y	Y	N	Dual wheel	Crank	Crank
Non-missing tooth on crank	Single tooth on cam	Y	Y	Y	Y	Y	Y	Y	Dual wheel	Crank	Cam
Non-missing tooth on crank	Cam wheel with tooth per cylinder	Y	N	N	N	Y	N	N	Dual wheel	Crank	Every Cylinder
Non-missing tooth on cam	Single tooth on cam	Y	Y	Y	Y	Y	Y	Y	Dual wheel	Cam	Cam
Non-missing tooth on cam	Single tooth on crank or two opposite teeth on cam	Y	Y	Y	N	Y	Y	N	Dual wheel	Cam	Crank
Non-missing tooth on cam	Cam wheel with tooth per cylinder	Y	N	N	N	Y	N	N	Dual wheel	Cam	Every Cylinder

For initial setup and determining tooth#1 angle on uncommon setups having timing marks or tape on your crank pulley/damper covering the full 360 degrees will be greatly helpful. Speed shops sell timing tape for a variety of damper diameters. If your engine has no timing marks you do need to add them. Just guessing at timing is a great way to damage an engine.



It is essential that ignition timing is confirmed with a timing-light on EVERY install.

Running excessive timing under load will almost always cause severe engine damage. Ignore this warning at your peril !

6.9.2 Terminology notes

Missing tooth - This is a regular wheel with a group of "missing" teeth e.g. 12-1, 36-1, 36-2, 60-2

on crank - the wheel is rotating at crank speed, normally directly attached to the crank pulley or flywheel

on cam - the wheel is rotating at camshaft or distributor speed

Single coil - a single coil and distributor

Wasted spark - double ended coils (or a pair of coils) that fire twice per cycle

Wasted-COP - a single coil per cylinder, but firing twice per cycle

COP - a single coil per cylinder that fires once per cycle

Batch/bank fire - groups of injector fired at once, not timed to a specific cylinder event

Semi-sequential - injectors fired twice per cycle timed to cylinder events

Sequential - each injector fires once per engine cycle timed to a specific cylinder event

6.9.3 Wheel naming

There does not appear to be universal agreement on the way to name wheels, however in the Megasquirt world, they will be named like the following examples.

36-1. This means a single wheel with place for 36 teeth and a single tooth omitted. i.e. 35 teeth at 10 (360/36) degree spacing.

36-2. This means a single wheel with place for 36 teeth and a two adjacent tooth omitted. i.e. 34 teeth at 10 (360/36) degree spacing.

36-1-1. This means a single wheel with place for 36 teeth and a two non-adjacent single tooth omitted. This type of wheel is not supported by "toothed wheel" - it is supported as Rover#1

36-2-2-2. This means a single wheel with place for 36 teeth and a three sets of double missing teeth. This type of wheel is not supported by "toothed wheel" - it is supported as 36-2-2-2 with the specific OEM pattern built into the decoder.

24/1. This means 24 teeth (non-missing) on one wheel and a single tooth on a second wheel.

36-1/1. This means a one 36-1 wheel and a single tooth on a second wheel.

3+1. This means one wheel with 3 equally spaced teeth and an additional tooth to indicate sync. (Supported somewhat as Daihatsu 3cyl)

Spark Mode - set to "Toothed Wheel"

Trigger Angle/Offset - always zero

Angle between main and return - n/a

Oddfire small angle - for oddfire engines this specifies the smallest of the crank angles between ignition events

GM HEI/DIS options - n/a

420A/NGC alternate cam - n/a

Use cam signal if available - n/a

Oddfire phasing - usually "Alternate" but for Vmax use "Paired"

Skip pulses - number of input pulses at startup that are ignored before decoding begins. Safe to leave at 3.

Ignition Input Capture - see ignition page

Spark output - see ignition page

Number of coils - see ignition page

Spark hardware in use - see ignition page

Cam input - see ignition page

Trigger wheel arrangement - see table above for correct settings

Trigger wheel teeth - the number of effective teeth, counting the missing teeth as if they existed. i.e. a 36-1 wheel has 35 physical teeth, but enter 36.

Missing Teeth - the number of missing teeth. Common are 1 for 36-1, or 2 for 60-2 or 36-2

Tooth #1 angle - definition depends on whether main wheel is missing or non-missing type. See sections below.

Main wheel speed - Does the main wheel rotate at crankshaft speed or camshaft (distributor) speed.

Second trigger active on - Like ignition input capture above, specifies which voltage level is considered "active"

Level for phase 1 - only applies in "Poll level" mode. See Dual+Missing section.

and every rotation of - how often are second trigger input pulses received. See Dual Wheel section

All of the settings on the right hand side of the page are general and will be covered in the Ignition manual.

There are two main categories of install - Retrofit and Existing.

6.9.4 Retrofit install

If you have an engine that did not originally come equipped with a trigger wheel (e.g. a distributor based, pre-EFI engine) then you have to mount a wheel and sensor and set the phasing correctly.



Suggestion for a typical car engine

Install a 36-1 wheel on the crank for accurate wasted spark ignition and batch-fire fuel.

For installs requiring COP or sequential fuel, install a 36-1 wheel on the crank and a 50/50 cam tooth with gear-tooth hall sensor.

60-2 works great on most engines too.

For very high revving engines (such as motorcycle engines) due to the number of teeth per second, 36-1, 24-1 or 12-1 are preferred. (Megasquirt-3 can reliably support higher revs and more teeth than Megasquirt-2.)

While the code can cope with any sensor/tooth phasing, during cranking the rpms vary up and down greatly as the engine rotates. It is desirable to place the missing tooth such that it passes the sensor when the engine speed is somewhat stable or it may be impossible for the ECU to "see" the missing tooth. The OEMs have found that certain tooth#1 angles work well and it is worth following their lead.

It is **suggested** to align your wheel and sensor to arrive at the following tooth #1 angles.

4 cylinders ~90-120 deg

6 cylinders ~50 deg

8 cylinders ~40 deg

Take a look at Appendix B pages for places to source used trigger wheels, sensors and coilpacks. Note that you do NOT need the EDIS module, so later ('internal-EDIS') cars are useful donors too.

Mounting the wheel is quite critical in that it MUST be mounted so it rotates without moving up, down, left or right as the sensor needs to see all of the teeth with a gap of 0.75 - 1.0mm.

The tooth size needs to be matched to the sensor. Make sure that the sensor is designed to operate with the tooth size on your wheel. If using an OEM part, then stick to the sizes that they used.

Very long single teeth, as used on some bike flywheels are not readily supported - consider retrofitting a toothed wheel instead.

Having mounted the wheel and sensor, you can proceed for an existing install.

6.9.5 Existing install

In this case where you are fitting Megasquirt to an engine already fitted with a trigger wheel, your main task is to wire up the sensor(s), determine the tooth #1 angle and wire up your coil(s). It should not normally be necessary to modify the trigger wheels.

6.9.6 Missing tooth crank wheel

This is a very common configuration for wasted spark with the most typical wheels being 36-1 (Ford) and 60-2 (Bosch.) Note that the missing teeth are in a single group - if your wheel has multiple groups then you need a special wheel decoder. Many custom decoders already exist e.g. 36-2-2-2 and the one matching your wheel must be used instead of this generic "toothed wheel" mode.

The software benefits from a reasonable number of teeth (hence 36 or 60) for best ignition timing accuracy. Low tooth count wheels such as 4-1 are not advised.

6.9.6.1 What is Tooth #1

With the engine rotating in the normal direction...

Tooth #1 is the first tooth to pass the sensor after the missing tooth gap.

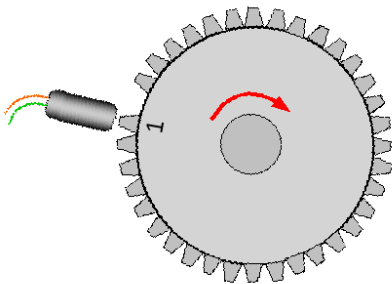

We use the term "tooth#1" as it is consistent across wheels with one, two, three or four missing teeth in the group.

Once the software knows the tooth#1 angle it automatically calculates other needed information internally.

The following table shows examples, in this case the tooth#1 angle happens to be 80 degrees.

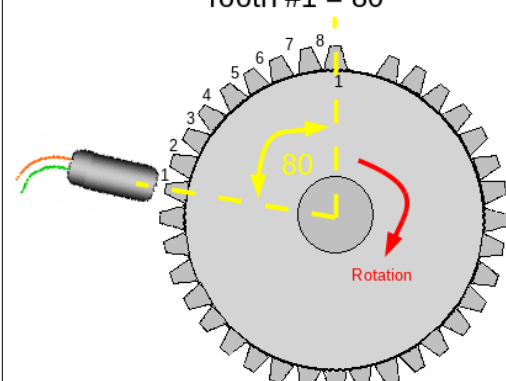
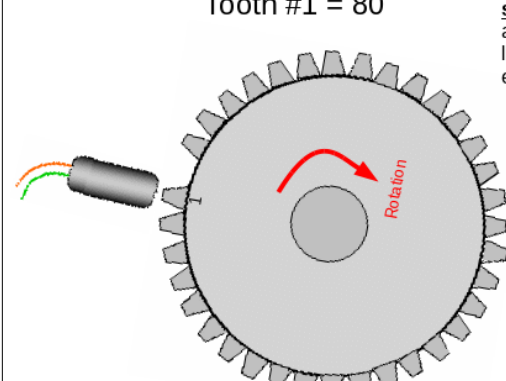
<p>Clockwise rotation (normal) - method a</p> <p>Set your engine at TDC, then count the number of GAPS to tooth#1 in the direction of rotation (clockwise here) and multiply by the angular size of the tooth. e.g. 8 teeth * 10 deg/tooth = 80 deg</p> <p>36-1 wheels are 10 deg per tooth 60-2 wheels are 6 deg per tooth 24-2 wheels are 15 deg per tooth</p>	<p style="text-align: center;">Tooth #1 = 80</p>  <p style="text-align: center;">Clockwise rotation</p> <p style="text-align: right;">With engine at TDC, the VR sensor aligns with the tooth that is 80 degrees earlier than Tooth#1. Count the gaps.</p> <p style="text-align: right;">Timing marks on damper</p>
<p>Clockwise rotation (normal) - method b</p> <p>A different way of looking at the SAME phasing.</p> <p>Turn your engine so that tooth #1 aligns with the sensor.</p> <p>Read off the tooth#1 angle from timing marks/tape on the crank pulley.</p>	<p style="text-align: center;">Tooth #1 = 80</p>  <p style="text-align: center;">Clockwise rotation</p> <p style="text-align: right;">This shows another view of the <u>same</u> sensor to missing-tooth alignment. When tooth #1 is lined up with the sensor the engine is at 80 BTDC.</p> <p style="text-align: right;">Timing marks on damper</p>

Typical settings:

- Spark mode = Toothed wheel
- Trigger angle/offset = 0 (not used in toothed wheel mode)
- Trigger wheel arrangement = Single wheel with missing tooth
- Trigger wheel teeth = number of teeth including missing teeth (e.g. 36, 60 etc.)
- Missing teeth = number of missing teeth (e.g. 1, 2)
- Tooth #1 angle = tooth #1 angle as determined above
- Main wheel speed = Crank wheel

Common combinations:

- Ford 4 cyl = 36-1, 80deg tooth #1
- Ford 6 cyl = 36-1, 50deg tooth #1
- Ford 8 cyl = 36-1, 40deg tooth #1
- Bosch 4 cyl (Peugeot, Vauxhall) = 60-2, 114 deg tooth #1

6.9.7 Missing tooth cam wheel

This arrangement is not commonly used by OEMs but does support full sequential with a single wheel and sensor. Cam triggering is less accurate than crank triggering due to timing belt or chain stretch.

The software benefits from a reasonable number of teeth (hence 36 or 60) for best ignition timing accuracy. Low tooth count wheels such as 8-1 are not advised.

The previous section on missing tooth crank wheel generally applies when the wheel is mounted to the cam, but remember that one rotation of the cam is 720 crank degrees. The settings are in crank degrees. So a tooth#1 that is 8 gaps earlier than the sensor on a 36-1 wheel would give a 160deg tooth#1 angle ($8 * 10 * 2$ [for cam])

Typical settings:

Spark mode = Toothed wheel

Trigger angle/offset = 0 (not used in toothed wheel mode)

Trigger wheel arrangement = Single wheel with missing tooth

Trigger wheel teeth = number of teeth including missing teeth (e.g. 36, 60 etc.)

Missing teeth = number of missing teeth (e.g. 1, 2)

Tooth #1 angle = tooth #1 angle as determined above

Main wheel speed = Cam wheel

6.9.8 Missing tooth crank wheel and single tooth cam wheel

This is a very common arrangement that supports full sequential and coil on plug.

(For 50/50 half-moon or 4-window wide/narrow or other polled cam wheels see section 6.9.9)

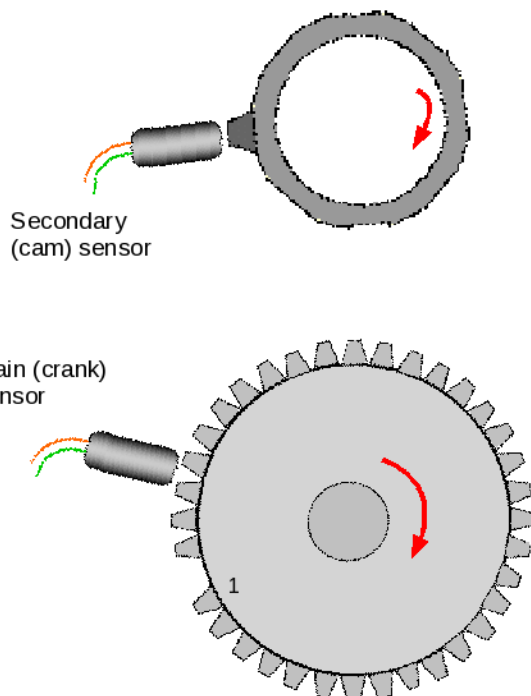

The definition of tooth#1 is the same as the basic missing tooth crank wheel and should be phased in the same

way. Ensure you also read the section above. The cam input tells the code which engine cycle/phase it is on. From the crank wheel alone the code knows when cylinder one is at TDC, but it cannot distinguish TDC compression or TDC exhaust. The cam sensor adds this information which is why it needs to be one pulse only per engine cycle.

The cam signal is a single pulse usually generated by a narrow tooth, vane or window. During setup, you will need to use the composite logger in TunerStudio to verify the phasing between the crank and cam signals is acceptable.

To confirm correct cam sensor phasing proceed as follows. (Note that some engines should not be rotated backwards, use tape or pen marks on the pulleys or sprockets to remember positions and rotate forwards only.)

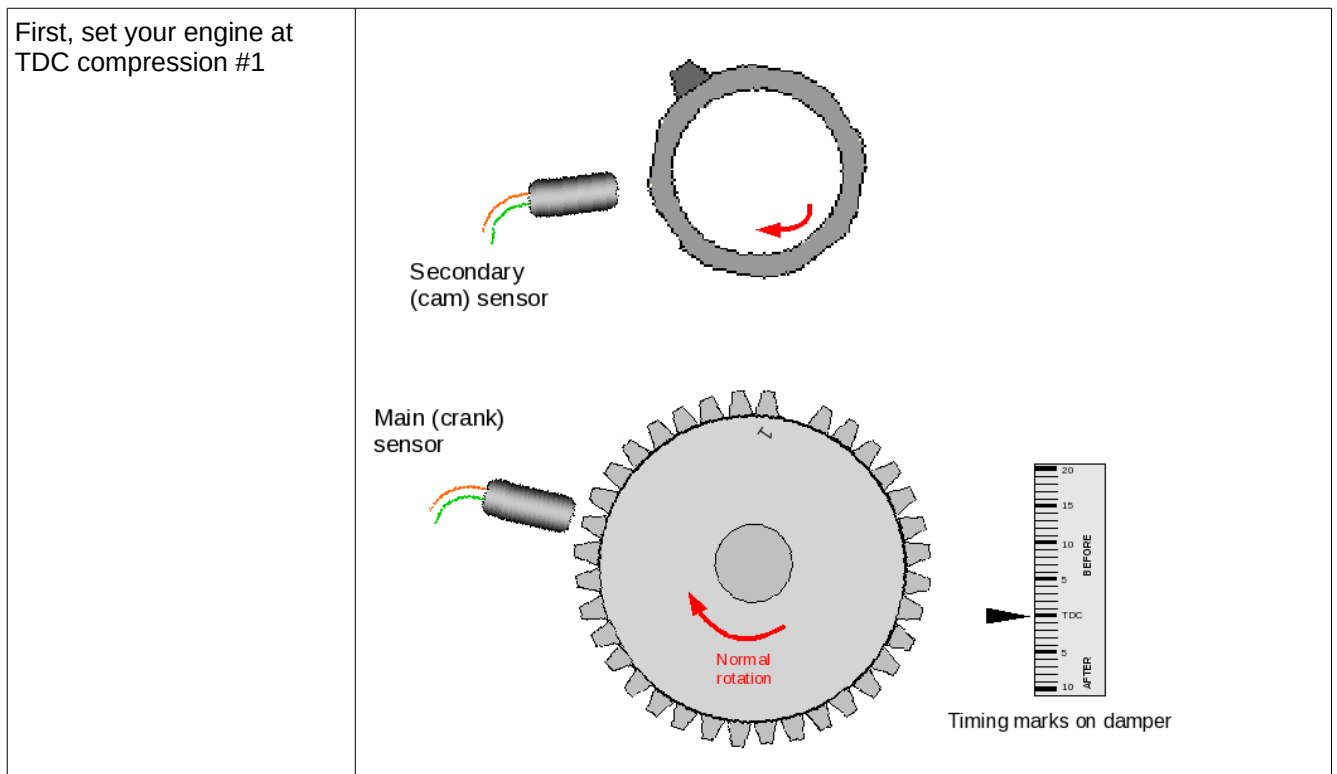

Now rotate the engine backwards to tooth#1

The angle read off the damper is the tooth#1 angle

Secondary (cam) sensor

Main (crank) sensor

Normal rotation

Turn backwards

Timing marks on damper

Now rotate the engine backwards some more - this is the best place for the cam tooth to pass the sensor.

Secondary (cam) sensor

Main (crank) sensor

Normal rotation

Turn backwards

Timing marks on damper

Typical settings:

Spark mode = Toothed wheel

Trigger angle/offset = 0 (not used in toothed wheel mode)

Trigger wheel arrangement = Dual wheel with missing tooth

Trigger wheel teeth = number of teeth including missing teeth (e.g. 36, 60 etc.)

Missing teeth = number of missing teeth (e.g. 1, 2)

Tooth #1 angle = tooth #1 angle as determined above

Main wheel speed = Crank wheel

Second trigger active on = Rising edge (confirm with composite logger)





6.9.9 Missing tooth crank wheel and polled cam wheel

This is a fairly common arrangement that supports full sequential and coil on plug. Here a missing tooth wheel is used on the crank in the common way and a hall-effect or gear-tooth sensor is used on the cam with a long tooth or window or vane. This gives you the ability to have full sequential, but the engine syncs up as fast as a regular missing tooth crank wheel.

Different OEM implementations exist - some engines use a 50/50 cam pattern, Vauxhall red-top engines use a window in the distributor rotor that spans the missing tooth region. Many newer engines with Bosch ECUs utilize a 4 tooth wide/narrow cam trigger, this is used on some VW, GM LS2, LS4 and some Mercedes. As far as the code is concerned these are equivalent because it only 'looks at' (polls) the cam just after the missing tooth to determine engine phase.

The wide/narrow type is used for VVT control on some engines and is supported by Megasquirt-3.

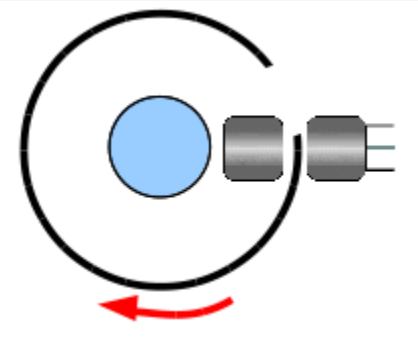
Typical polled cam triggers:

		<p>4 tooth wide/narrow type e.g. GM LS2 4X / VW / Mercedes</p>
		<p>Vane cup with single window e.g. 1 window Bosch dizzy in Vauxhall red-top.</p>

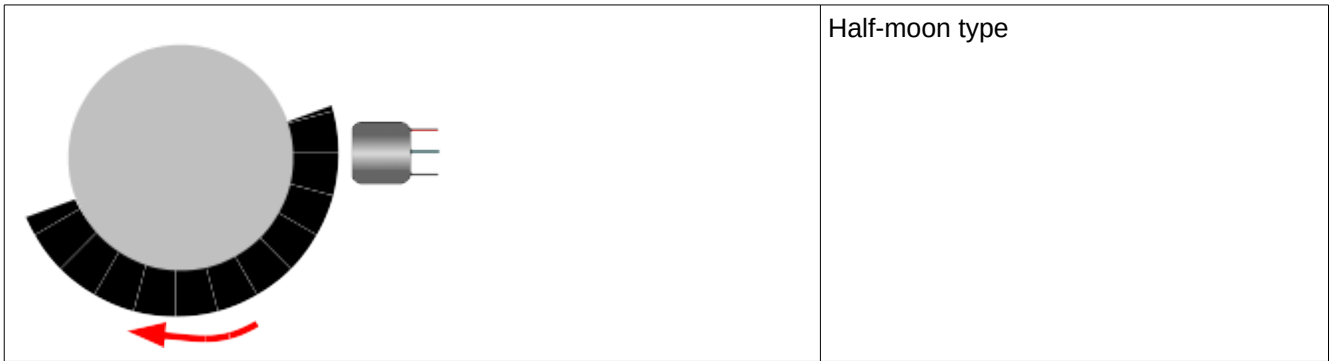

General arrangement

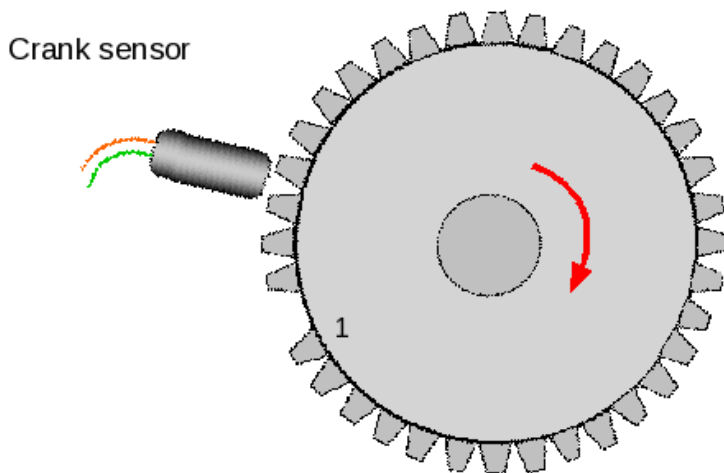
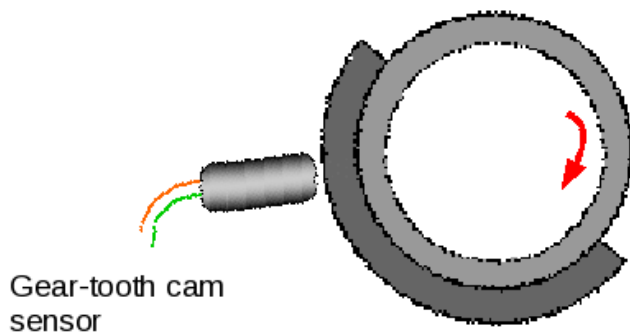

The definition of tooth#1 is the same as the basic missing tooth crank wheel and should be phased in the same way. The cam input tells the code which engine cycle/phase it is on - the 'tooth' should be normally start at least 20 crank degrees before tooth#1 and continue for another 20 crank degrees afterwards. (The level is actually polled at tooth#2.)

At close to tooth#1 the code examines the voltage level on the input to determine which phase it is on - the 'tooth' should be normally start at least 20 crank degrees before tooth#1 and continue for another 20 crank degrees afterwards. (The level is actually polled at tooth#2.)

The additional teeth on the long/short cam wheel do not matter.

To confirm correct cam sensor phasing proceed as follows.

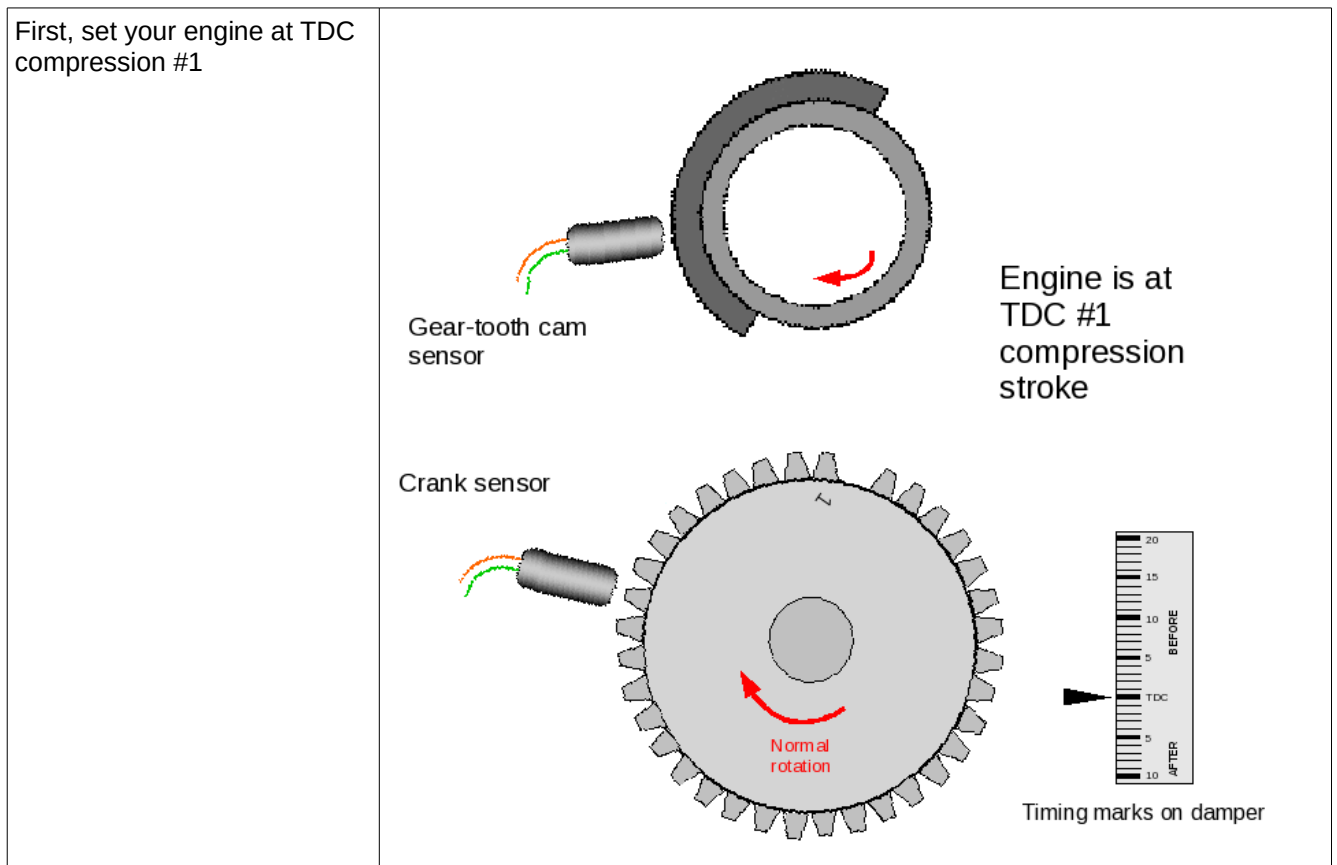

Now rotate the engine backwards to tooth#1

The cam sensor should be roughly in the middle of window/tooth/vane

With the cam sensor powered and connected to the Megasquirt measure the output voltage.

A voltage of ~0V here requires the HIGH setting and a voltage of ~5V here requires the LOW setting.
 ??? Check ???

Gear-tooth cam sensor

Crank sensor

Normal rotation

Turn backwards

Tooth #1 compression stroke

Timing marks on damper

Now rotate the engine backwards a full revolution.

The cam sensor will be opposite that previous window/tooth/vane. (If there was a window before it must be a vane now and vice-versa.)

Gear-tooth cam sensor

Crank sensor

Normal rotation

Turn backwards one complete rev

Tooth #1 exhaust stroke

Timing marks on damper

Typical settings:

Spark mode = Toothed wheel

Trigger angle/offset = 0 (not used in toothed wheel mode)

Trigger wheel arrangement = Dual wheel with missing tooth

Trigger wheel teeth = number of teeth including missing teeth (e.g. 36, 60 etc.)

Missing teeth = number of missing teeth (e.g. 1, 2)

Tooth #1 angle = tooth #1 angle as determined above

Main wheel speed = Crank wheel

Second trigger active on = Poll level

Level for phase one = as determined above

6.9.10 Nippondenso CAS

The Nippondenso CAS (crank angle sensor) comes in a number of versions which all use a 24 tooth main wheel and a second wheel with one, two, three or four teeth. There is a single sensor (called Ne) pointing at the 24 tooth wheel and one (G1) or two (G1 and G2) sensors pointing at the second wheel.

This style of CAS is very common on Toyota and Mazda engine from the 1980s and 1990s.

The number of teeth on the second wheel determines whether it can be used (without modification) for single coil distributor, wasted spark or coil-on-plug (COP) and sequential.

The version with a single tooth and two pickup sensors is intended for sequential. The two sensors are used by the OEM to allow the engine to synchronize within one engine revolution. Presently we only support using one of the 'G' sensors.



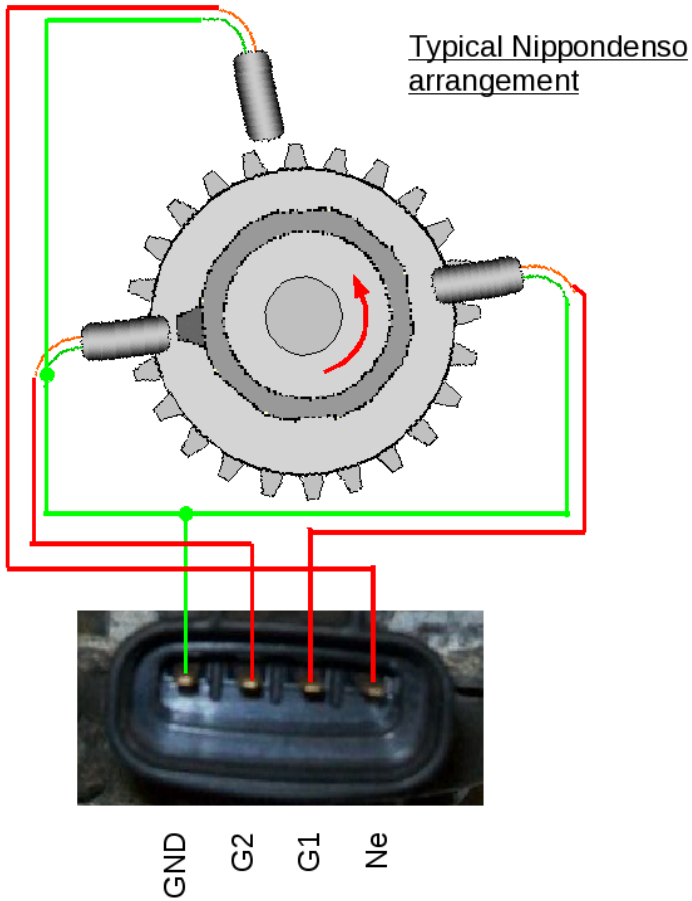

CAS connection	Megasquirt connection
NE- / GND	Pin 2 / GND
Ne	Tach in
G1 or G2	Cam input
Other G	not used

6.9.10.1 NipponDenso CAS with single G tooth

With the single tooth every 720 degrees this setup gives enough engine information for full sequential fuel and spark.

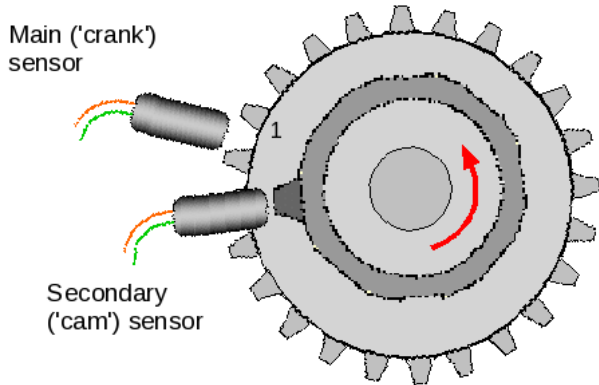

What is Tooth #1

With the engine rotating in the normal direction...

Tooth #1 is the first tooth to pass the main sensor after the single tooth has passed the second sensor.

Make sure these do not happen at the same time - in the diagram you can see that the main sensor is over a gap when the secondary sensor is aligned with its tooth.

<p>First, set your engine at TDC compression #1</p>	<p>Engine is at TDC #1 compression stroke</p> <p>Timing marks on damper</p>
---	---

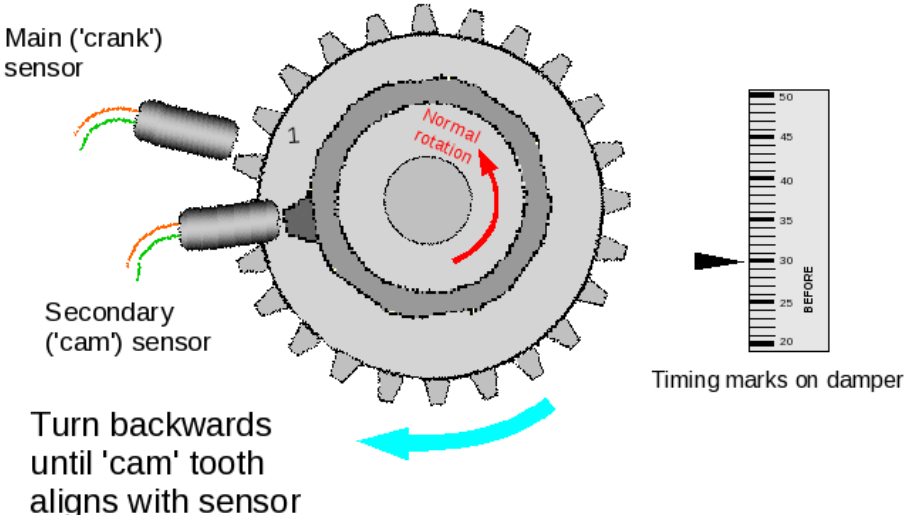
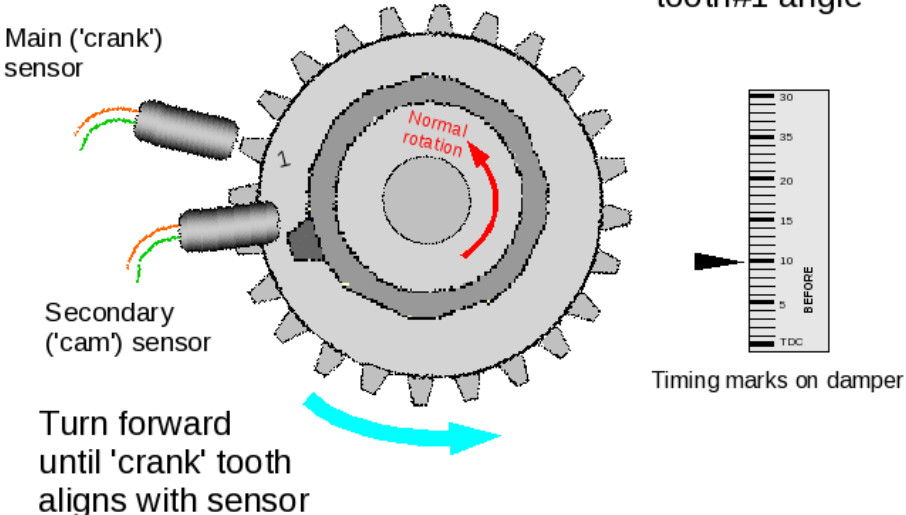
<p>Now rotate the engine backwards until the 'cam' sensor and tooth line up. If you rotated more than one turn, then add 360 to your tooth#1 angle.</p>	 <p>Turn backwards until 'cam' tooth aligns with sensor</p>
<p>Now rotate the engine forwards until the next 'crank' tooth aligns with its sensor. The crank angle now is the tooth#1 angle. (Note that angles shown in diagram are examples only)</p>	 <p>Crank angle is tooth#1 angle</p> <p>Turn forward until 'crank' tooth aligns with sensor</p>

Typical settings:

- Spark mode = Toothed wheel
- Trigger angle/offset = 0 (not used in toothed wheel mode)
- Trigger wheel arrangement = Dual wheel
- Trigger wheel teeth = number of teeth
- Tooth #1 angle = tooth #1 angle as determined above
- Main wheel speed = Cam wheel
- Second trigger active on = Rising (verify with composite logger)
- and every rotation of = Cam

6.9.10.2 NipponDenso CAS with two G teeth

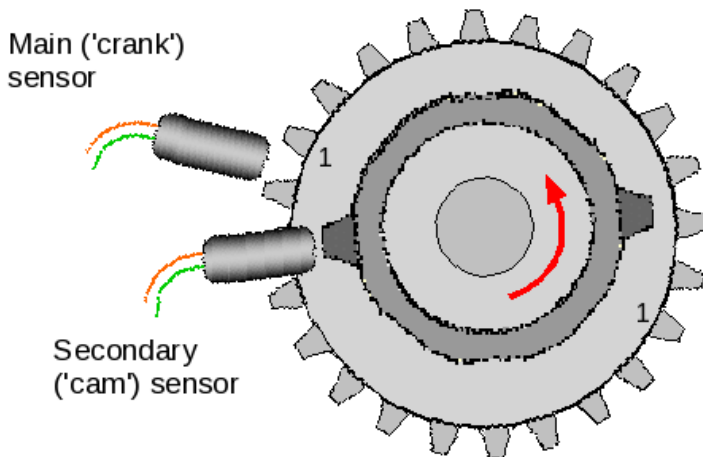

With the cam tooth every 360 degrees this setup gives enough engine information for semi-sequential fuel and wasted spark. (On a rotary such as the RX7, or a two-stroke engine, full sequential fuel and spark is possible as the engine cycle spans 360 degrees.)

What is Tooth #1

With the engine rotating in the normal direction...

Tooth #1 is the first tooth to pass the main sensor after either cam tooth has passed the second sensor.

Make sure these do not happen at the same time - in the diagram you can see that the main sensor is over a gap when the secondary sensor is aligned with its tooth.

Use the instructions in the previous single cam tooth section to determine your tooth#1 angle. It will always be between 0 and 360 degrees.

Typical settings:

Spark mode = Toothed wheel

Trigger angle/offset = 0 (not used in toothed wheel mode)

Trigger wheel arrangement = Dual wheel

Trigger wheel teeth = number of teeth

Tooth #1 angle = tooth #1 angle as determined above

Main wheel speed = Cam wheel

Second trigger active on = Rising (verify with composite logger)

and every rotation of = Crank

6.9.10.3 NipponDenso CAS with three or four G teeth

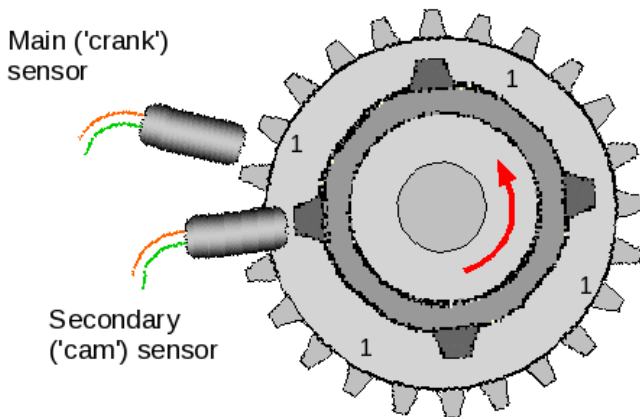

This version is used on three and four cylinder engines with one G tooth per cylinder.

There is only enough position information to run a distributor and untimed injection.

It is not strictly necessary to use both Ne and G wheels. Using both will give you the improved timing accuracy from the 'every-tooth' wheel decoder system, but for simpler installs it is possible to use the 'G' input only and configure as "Basic Trigger" instead. Timing will not be as accurate though.

What is Tooth #1

With the engine rotating in the normal direction...

Tooth #1 is the first tooth to pass the main sensor after either cam tooth has passed the second sensor.

Make sure these do not happen at the same time - in the diagram you can see that the main sensor is over a gap when the secondary sensor is aligned with its tooth.

Use the instructions in the previous single cam tooth section to determine your tooth#1 angle. It will always be between 0 and 360 degrees.

Typical settings:

Spark mode = Toothed wheel

Trigger angle/offset = 0 (not used in toothed wheel mode)

Trigger wheel arrangement = Dual wheel

Trigger wheel teeth = number of teeth

Tooth #1 angle = tooth #1 angle as determined above

Main wheel speed = Cam wheel

Second trigger active on = Rising (verify with composite logger)

and every rotation of = Every cylinder

6.9.11 Non-missing tooth crank wheel with one cam tooth

This arrangement is not commonly used by OEMs but could be used to extend a simple 'distributor' crank trigger to support sequential. It can also be useful on bike engines with very uneven cranking RPMs that struggle to detect the gap in a missing tooth wheel.

Generally Megasquirt benefits from many crank teeth to improve ignition timing accuracy. However, with this

wheel arrangement, you need to beware of trying to use too many teeth on the crank as there is a risk of the trigger inputs overlapping as the cam belt or chain stretches. If this overlap occurs, it will cause sync-loss as the cam tooth moves from being seen "before" to "after" a crank tooth or vice-versa.

12 crank teeth is the suggested maximum.

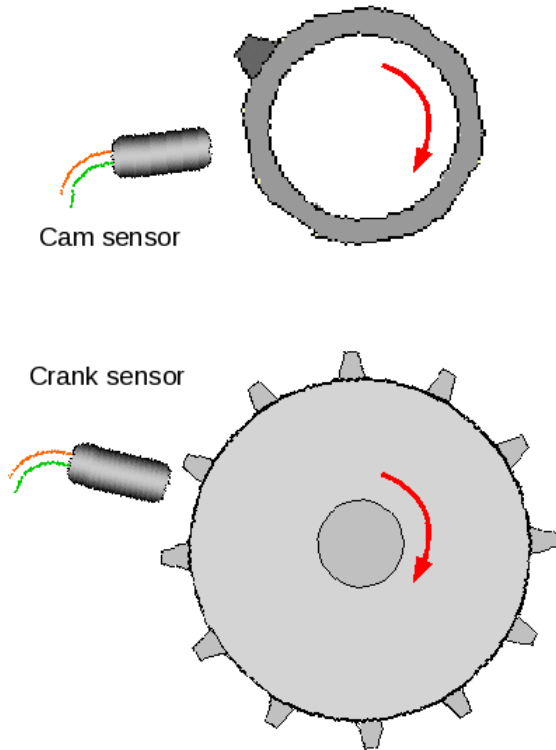

What is Tooth #1

With the engine rotating in the normal direction...

Tooth #1 is the first tooth to pass the main sensor after the cam tooth has passed the second sensor.

Make sure these do not happen at the same time - in the diagrams below you can see that the main sensor is over a gap when the secondary sensor is aligned with its tooth.

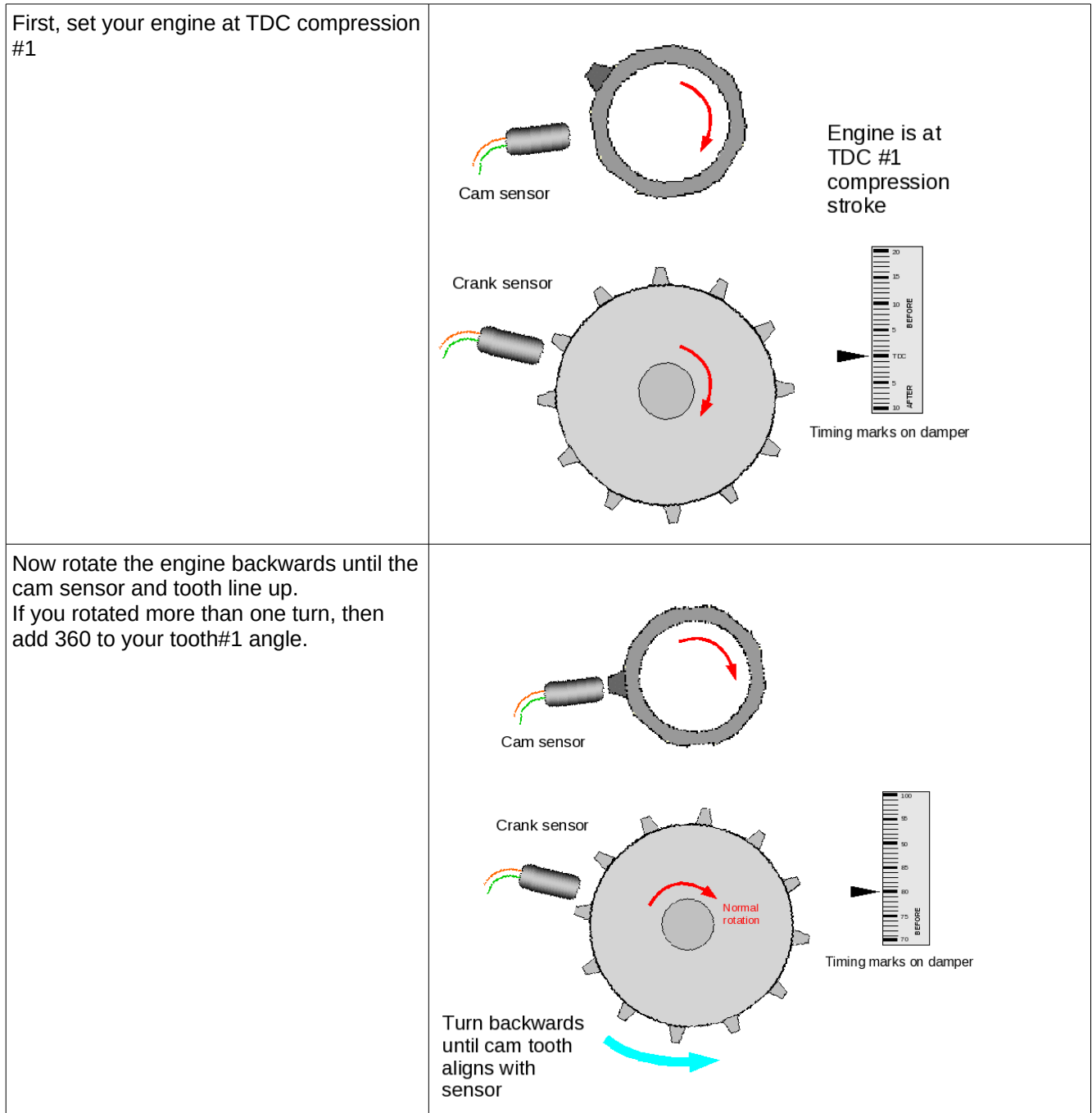

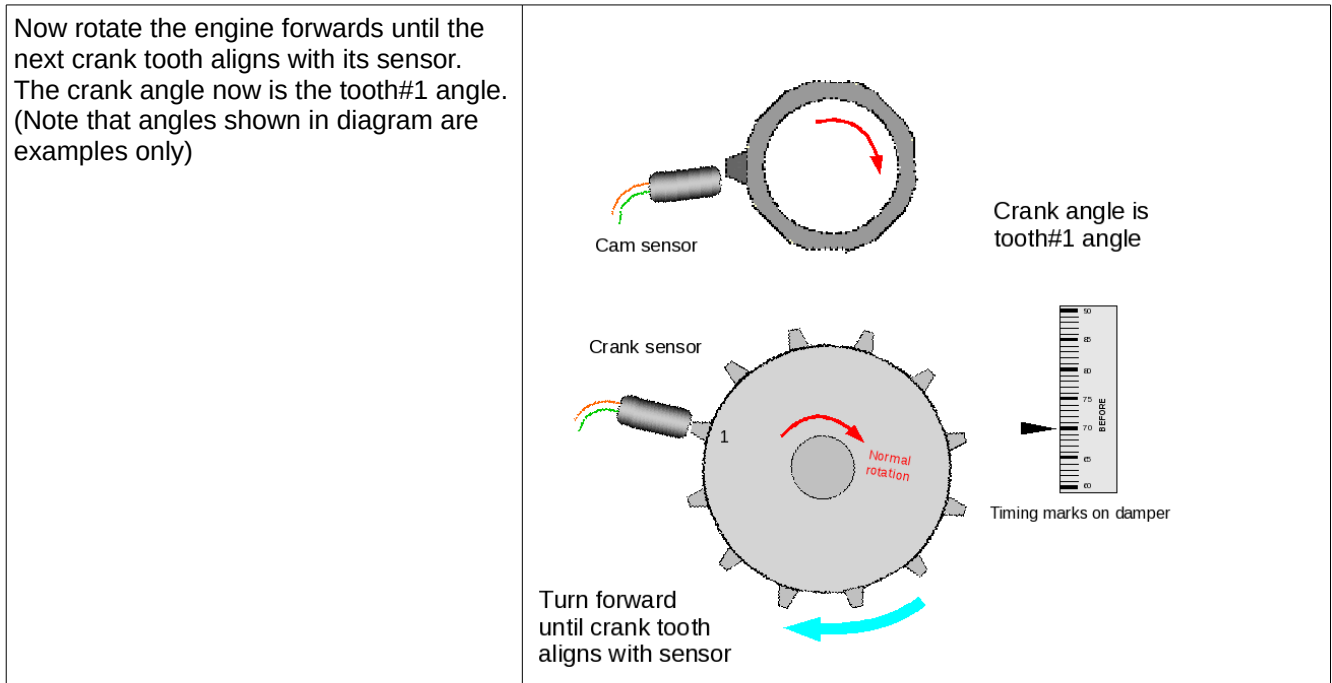

Typical settings:

- Spark mode = Toothed wheel
- Trigger angle/offset = 0 (not used in toothed wheel mode)
- Trigger wheel arrangement = Dual wheel
- Trigger wheel teeth = number of teeth
- Tooth #1 angle = tooth #1 angle as determined above
- Main wheel speed = Crank wheel
- Second trigger active on = Rising (verify with composite logger)
- and every rotation of = Cam

6.9.12 Mitsubishi CAS with aftermarket disc - single coil / wasted spark

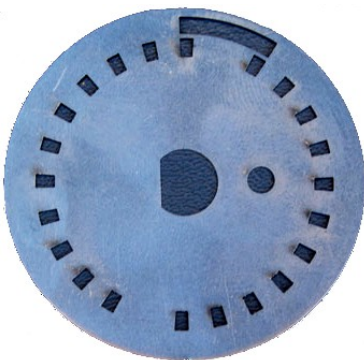

This replacement trigger disc is equivalent to a 12-1 wheel at crank speed with a single pulse on the cam.

The inner signal alone is good enough to run a single coil or distributor.

The addition of the outer single slot signal allows for coil-on-plug or sequential fuel.

Other variants exist.

For single-coil or wasted spark, only the inner track is required.

Set the mainboard as per section 5.2.3

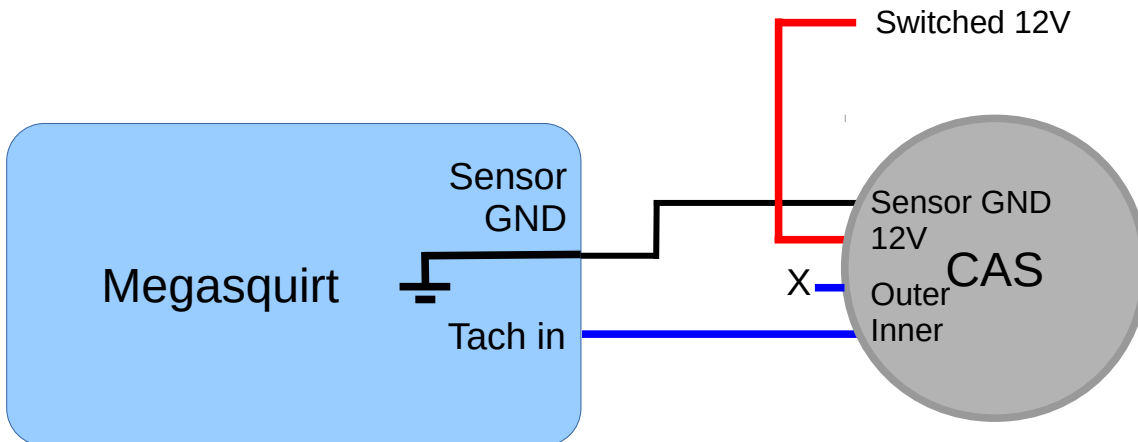

Typical settings:

- Spark mode = Toothed Wheel
- Trigger Angle/Offset = 0 (not used)
- Ignition input capture = ????
- Spark Output = Depends on coils / ignitors
- Number of coils = Wasted Spark
- Trigger wheel arrangement = Single wheel with missing tooth
- Trigger wheel teeth = 12
- Missing teeth = 1
- Tooth #1 angle = 345 (confirm with strobe)
- Wheel speed = Crank wheel

6.9.13 Mitsubishi CAS with aftermarket disc - coil-on-plug

With the same replacement as shown in 6.9.12, both sensor outputs can be wired to allow coil-on-plug. Set the mainboard as per section 5.2.3 and add a cam input as per section 5.2.14.2

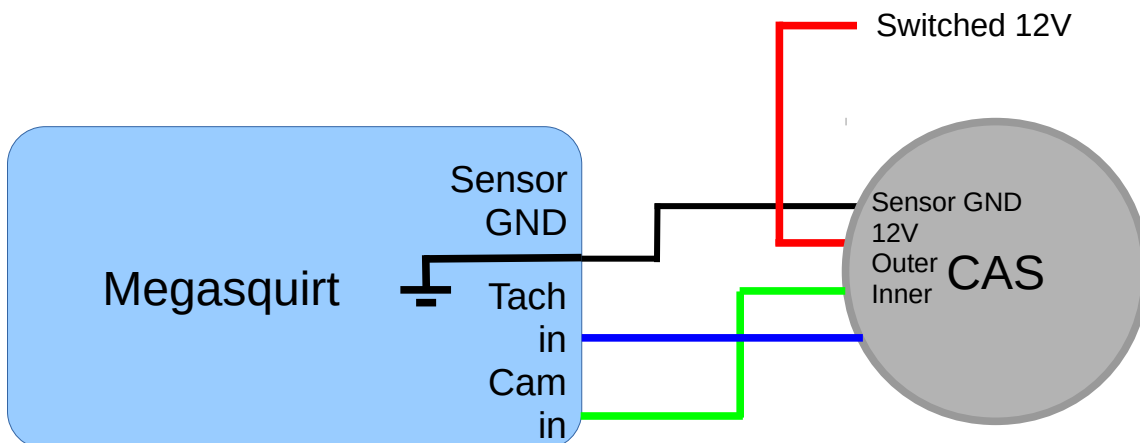

Typical settings:

Spark mode = Toothed Wheel
Trigger Angle/Offset = 0 (not used)
Ignition input capture = ????
Spark Output = Depends on coils / ignitors
Number of coils = Coil on plug
Trigger wheel arrangement = Dual wheel with missing tooth
Trigger wheel teeth = 12
Missing teeth = 1
Tooth #1 angle = 345 (confirm with strobe)
Wheel speed = Crank wheel
Second trigger active on = poll level
Level for phase 1 = ???

6.9.14 Other wheel arrangements

The examples shown here are not an exhaustive list of all the combinations that are possible, for other arrangements of crank and cam wheels you will need to apply the general principles to your install.

6.9.15 Example: Ford Zetec

The Ford Zetec is a popular four-cylinder four-stroke used on many Fords from the mid nineties onwards. As standard these engines use a 36-1 crank wheel and a VR sensor. Set the mainboard as per section 5.2.2.

A high-current coilpack is used and requires an external 2 channel ignitor.

Megasquirt-3 only needs the crank signal to run wasted-spark and batch fire fuel, this is the simplest configuration.

(Connecting and configuring the cam signal would allow sequential fuel and coil-on-plug ignition with suitable coils.)

Alternative #1: Customise the mainboard for two high current outputs.

Alternative #2: use a logic wasted spark coil pack such as the VW item (032 905 106B) shown in section: 5.3.2 instead of the stock coilpack.

Typical settings:

Spark mode = Toothed Wheel
Trigger Angle/Offset = 0 (not used)
Ignition input capture = Rising (confirm with tooth logger)
Spark Output = Going High
Number of coils = Wasted Spark
Trigger wheel arrangement = Single wheel with missing tooth
Trigger wheel teeth = 36
Missing teeth = 1
Tooth #1 angle = 90 (tweak with strobe)

Wheel speed = Crank wheel

6.10 Neon/420A

The "Neon/420A" mode supports the following vehicles when equipped with a 2.0 or 2.4 4-cylinder Chrysler engine. Also known as "1st gen Neon".

"NS" body models:

1996-2000 Chrysler Town and Country

1996-2000 Dodge Caravan/Grand Caravan

1996-2000 Plymouth Voyager/Grand Voyager

"JA" body models:

1995-02 Chrysler Cirrus

1995-02 Dodge Stratus

1996-2000 Plymouth Breeze

"JX" body models:

1996-02 Chrysler Sebring Convertible

"PL" body models:

1995-02 Dodge Neon

1995-2001 Plymouth Neon

"PT" body models:

01-02 Chrysler PT Cruiser

"FJ" body models:

1995-02 Chrysler Sebring Coupe

1995-2000 Dodge Avenger

The crank and cam signal pattern looks as follows:

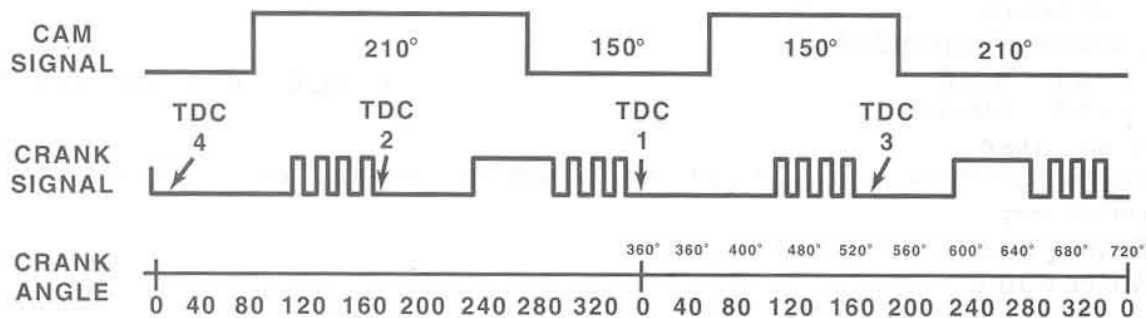

Megasquirt-3 only needs the crank signal to run wasted-spark and batch fire fuel, this is the simplest configuration.

(Connecting and configuring the cam signal would allow sequential fuel and coil-on-plug ignition with suitable coils.)

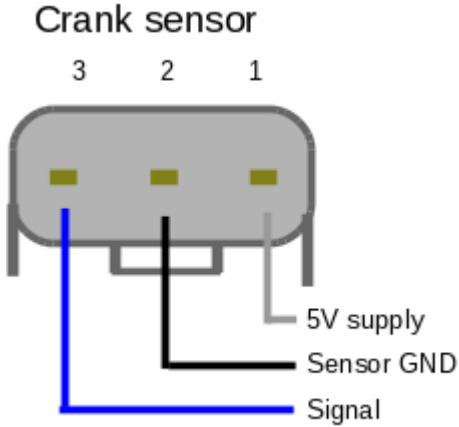

The following diagram shows the recommended wiring using an external ignitor to drive the standard 420A high-current coilpack.

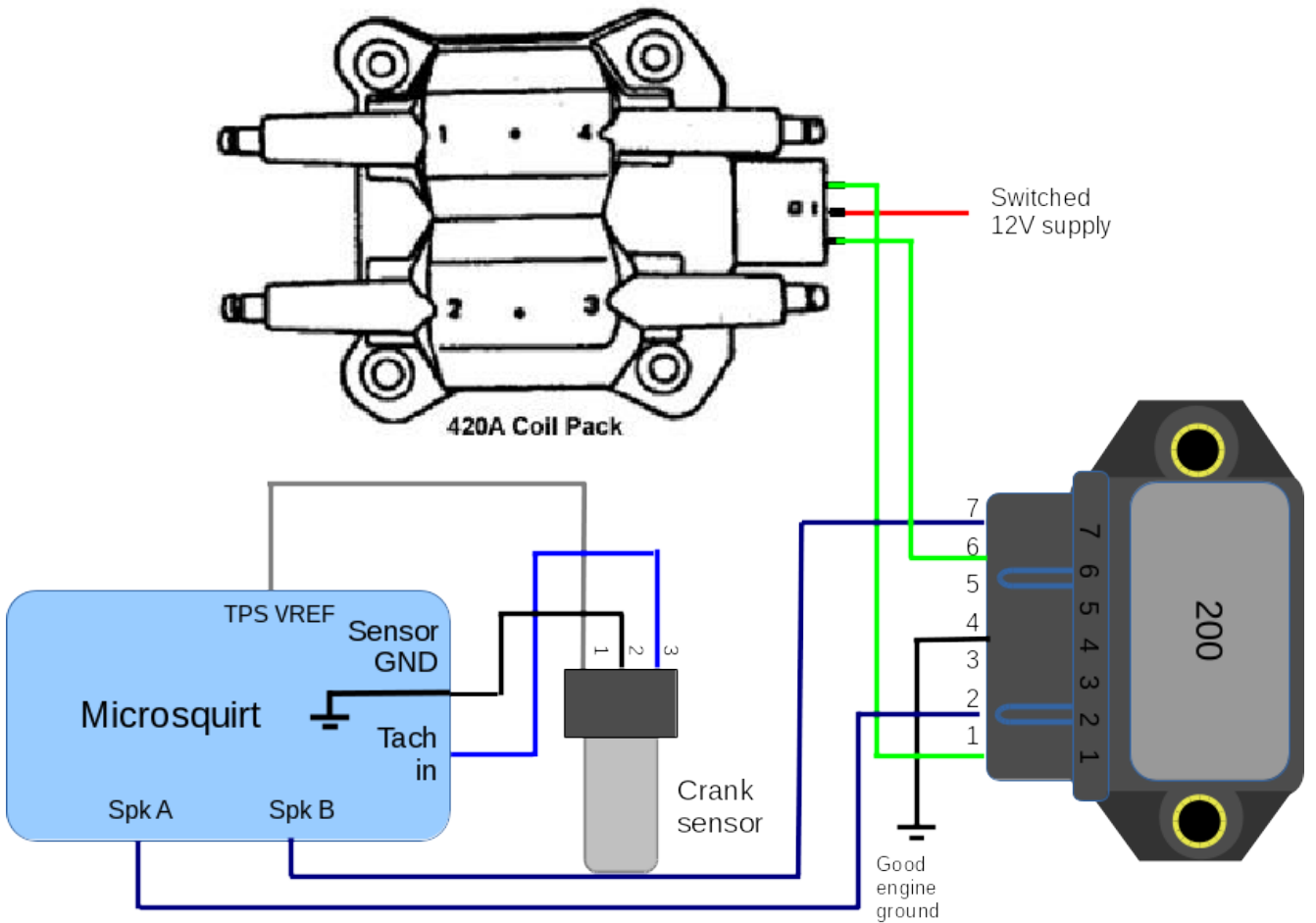

Alternative #1: Use an a different ignitor such as the Quadspark.

Alternative #1: Customise the mainboard for high current outputs.

Alternative #2: use a logic wasted spark coil pack such as the VW item (032 905 106B) shown in section: 5.3.2 instead of the stock coilpack.

Typical settings:

- Spark mode = 420A
- Trigger Angle/Offset = 0 (tweak if required)
- Ignition input capture = Rising edge
- Spark Output = Going High
- Number of coils = Wasted Spark

Injectors are wired up using the general diagrams in section 4.10.2

6.11 36-2+2 (NGC)

This ignition mode supports Chrysler's "next gen crank" pattern which was an attempt to consolidate the multitude of crank and cam patterns in use across Chrysler engines. It consists of 36 evenly space slots in a crank wheel, with a -1 (or -2) and +1 (or +2) pattern. The cam patterns vary across 4, 6, 8 cylinder variants.

NGC patterns came into use around 2002.

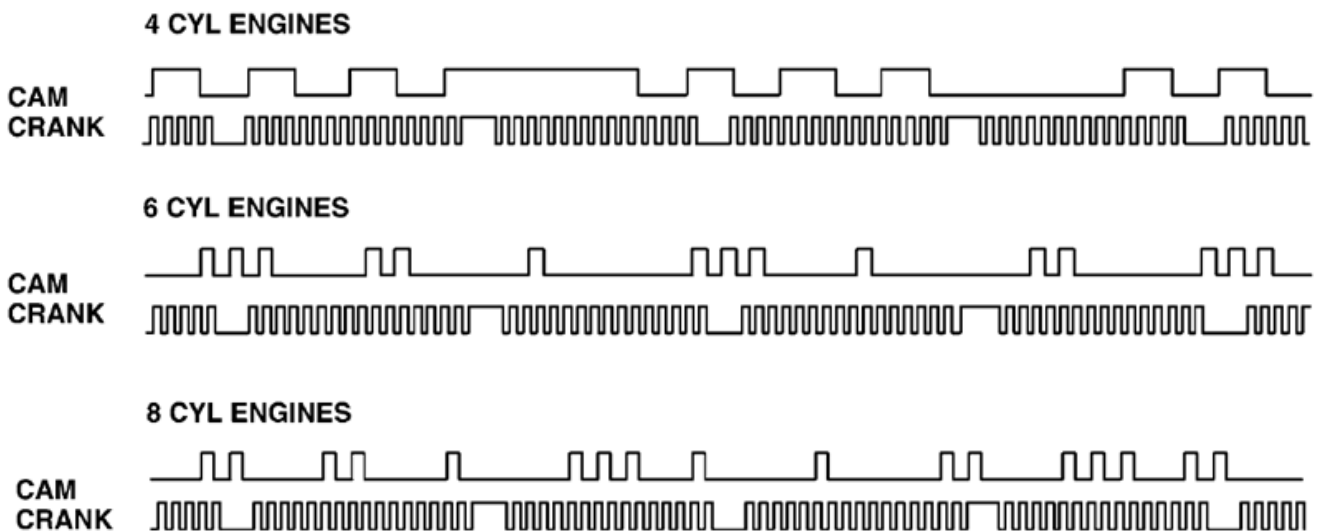

Megasquirt-3 only needs the crank signal to run wasted-spark and batch fire fuel, this is the simplest configuration. Set the mainboard as per section 5.2.3.

Four cylinder example, wired up the same as 420A in section 6.10

Typical settings:

- Spark mode = 36-2+2
- Trigger Angle/Offset = 0 (tweak if required)
- Ignition input capture = Rising Edge
- Spark Output = Going High
- Number of coils = Wasted Spark

Six and eight cylinder variants are wired up similarly, following the general ignitor and coil wiring diagrams in section 5.3.

6.12 36-2-2-2

The 36-2-2-2 mode is designed for use with 4-cyl Subarus and Mazda RX8 engines with stock trigger wheels and sensor positions. (Firmware 1.4.x supports 6-cyl Subaru also.)

As standard, these engines use VR type crank sensors.

See the generic instructions in section 5.2.

Mazda RX8 engines

RX8 engines use rotary specific coils - see section 5.3.6 for wiring.

Typical settings:

Spark mode = 36-2-2-2

Trigger Angle/Offset = 0 (tweak if required)

Ignition input capture = Falling Edge (typically)

Spark Output = Going High

Number of coils = Coil on Plug

Subaru 4cyl engines

Typically, the cam sensor is not used and "wasted spark" or "wasted COP" should be used. An external ignitor will be required to drive the high current coil.

Typical settings:

Spark mode = 36-2-2-2

Trigger Angle/Offset = 0 (tweak if required)

Ignition input capture = Falling Edge (typically)

Spark Output = Going High

Number of coils = Wasted Spark

6.13 Miata 99-05

The 99-05 Miata uses a low resolution crank trigger for primary timing and teeth on camshaft to detect phase. Both crank and cam inputs need to be connected.

See the generic instructions in section 5.2.

Most engines of this era run coil-on-plug ignition using logic coils.

See the generic instructions in section 5.3.2 for wiring four logic coils.

Improved timing accuracy can be obtained by upgrading to a regular toothed wheel on the crank shaft, such as the Flyin-Miata 36-2 wheel. (See also section 6.37)

Typical settings:

Spark mode = Miata 99-05

Trigger angle/offset = 0 (adjust with strobe)

Ignition input capture = Rising Edge (Set according to whichever edge gives the most stable signal. If timing advances with RPM, try flipping it.)

Spark output = Going High

Number of coils = Wasted Spark

6.14 Subaru 6/7

This mode is designed for the EJ series engines with the unique "6/7" trigger - there are six unevenly spaced teeth on the crank wheel and seven teeth in total on the cam sprocket for cylinder identification. Both crank and cam inputs need to be connected..

VR sensors are used which can be directly connected, although some experimentation may be required with resistor "shunts" as the signals have been troublesome for some.

See the generic instructions in section 5.2.

Some/most engines use a wasted spark coil pack. These are believed to be high current and will require an external ignitor.

Typical settings:

Spark mode = Subaru 6/7

Trigger angle/offset = 0 (adjust with strobe)

Ignition input capture = Set according to whichever edge gives the most stable signal. (If timing advances with RPM, try flipping it.)

Spark output = Going High

Number of coils = Wasted Spark

6.15 6G72

Known applications include:

- Mitsubishi 3000GT
- Mitsubishi Galant V6
- Some other Mitsubishi and Chrysler V6 models



1991-1992 6G72 use an optical CAS.

Electrically, the two signals on these CAS are connected the same as two hall sensors.

See sections 5.2.3 and 5.2.14.2 for mainboard modifications.

The outer track is considered to be the 'crank' signal and the inner track is the 'cam'.

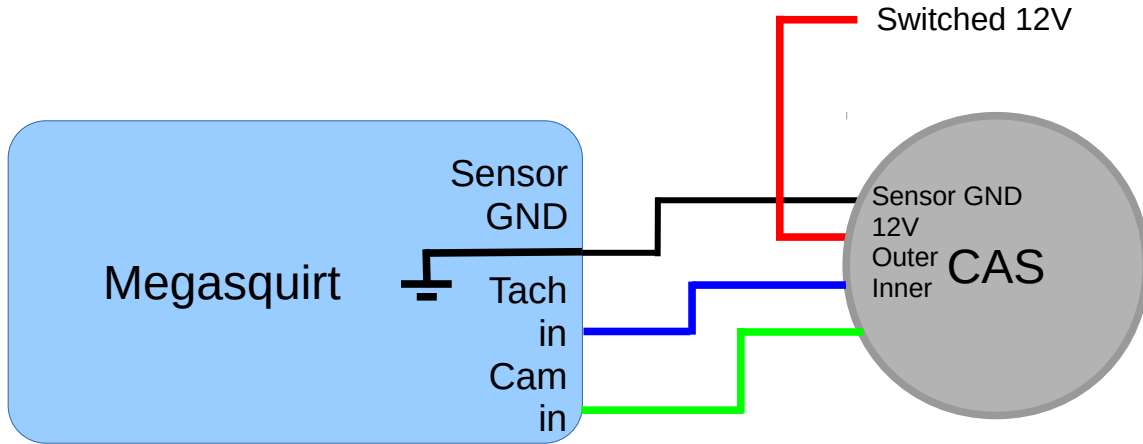

Later 6G72 use two independent sensors on crank and cam, but the signal pattern to the ECU is the same.

Connect crank sensor to Tach in

Connect cam sensor to Cam in

Typical settings:

Spark mode = 6G72

Trigger angle/offset = 0 (adjust with strobe)

Ignition input capture = Rising edge

Spark output = Going High

Number of coils = Wasted Spark

6.16 IAW Weber

Known applications include:

- Ford Sierra Cosworth
- Some Fiat and Lancia applications

This application uses a four tooth crank trigger with a VR sensor and a two tooth cam trigger with a Hall effect or VR sensor, depending on the year.

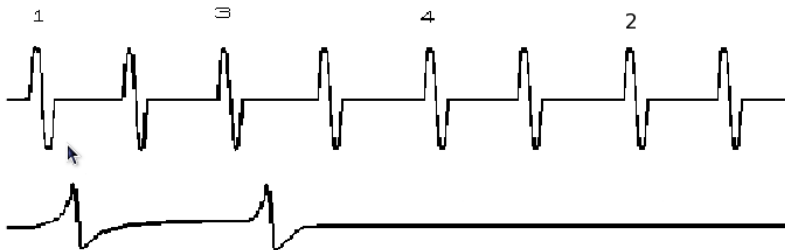

All models, see section 5.2.2 for mainboard modifications for the crank input.

Models with a VR cam sensor, see section 5.2.14.1 for mainboard modifications.

Models with a hall effect cam sensor, see section 5.2.14.2 for mainboard modifications.

Typical settings:

Spark mode = IAW Weber

Trigger angle/offset = 0 (adjust with strobe)

Ignition input capture = Falling edge

Spark output = Going High

Number of coils = Depends on application

Some applications use a single high current coil, others use coil-on-plug. External ignitors are likely required.

6.17 Mitsubishi CAS 4/1

Known applications include:

- Mitsubishi 4G91
- Mazda Protege and 323 with optical distributor

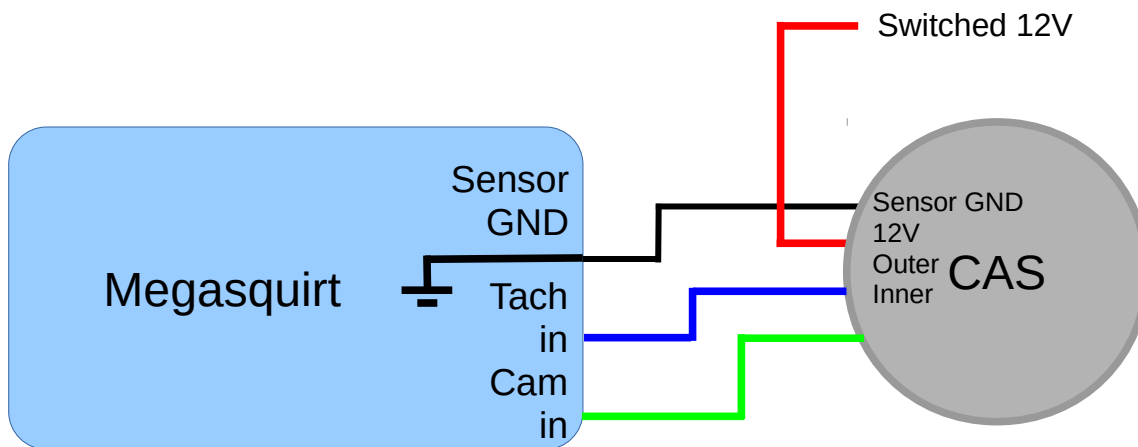

See sections 5.2.3 and 5.2.14.2 for mainboard modifications.

Typical settings:

Spark mode = CAS 4/1

Trigger angle/offset = 0 (adjust with strobe)

Ignition input capture = Falling edge

Spark output = Going High

Number of coils = Depends on application

You will need to set the "Angle between main and return" parameter to the distance between edges of the optical sensor.

Note that if you are not able to get a stable signal off both edges, you should instead use "Toothed Wheel", mode with "Dual wheel" and 4 teeth at cam speed set.

6.18 Mitsubishi 4G63 (and Miata)

Known applications include:

- Mitsubishi 4G63 with distributorless ignition, as used in Eclipse, Galant VR4, and Lancer Evolution
- 1990-1997 Mazda MX5 Miata

- 2G 4G63
- pre-1999 Miata (MX5) use a Mitsubishi optical CAS.
- Mitsubishi EVO



4G63 2G CAS

Electrically, the two signals on these CAS are connected the same as a hall sensor and require a pair of pull-up resistors in the wiring harness.

Nissan CA18DET
VG30DETT
Mitsubishi 4G63

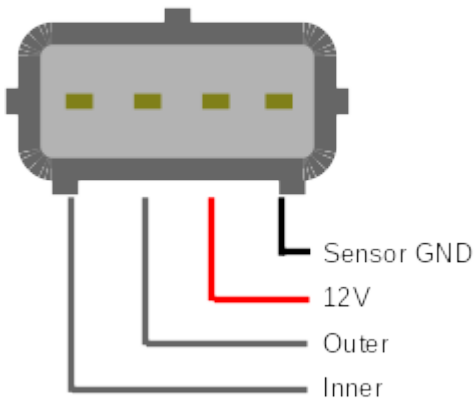

Nissan SR20DET
Mazda Miata/MX5

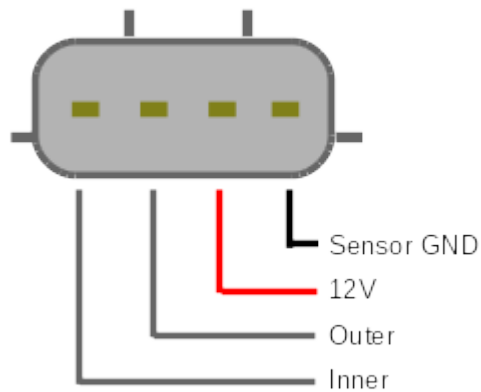

The outer track is considered to be the 'crank' signal and the inner track is the 'cam'.

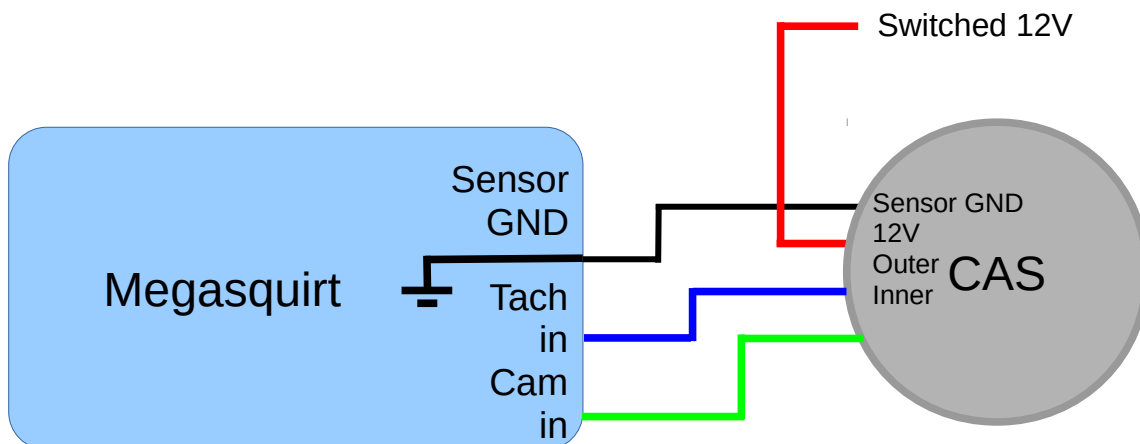

Later 4G63 use two independent hall sensors with a two tooth crank trigger and a two tooth cam trigger, but the signal pattern to the ECU is the same.

Some 4G63 applications may use slightly different CASEs. Use the composite logger in "log crank & cam" to compare the pattern.

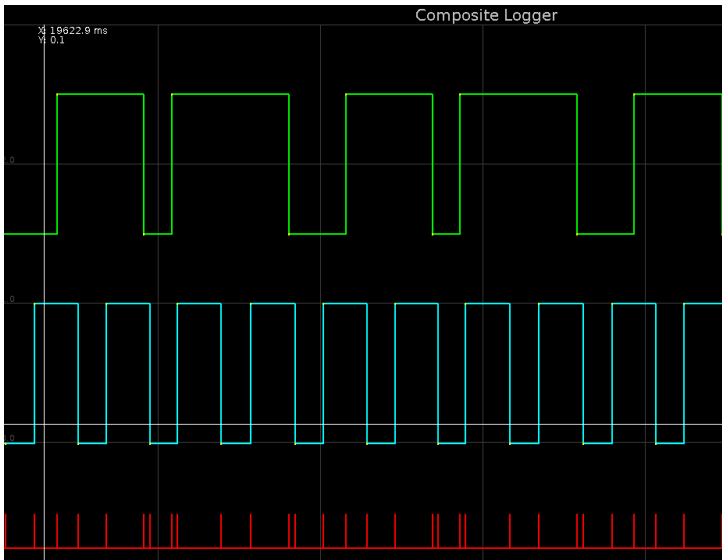

Composite log of 4G63 CAS (from Miata) recorded using "Log crank & Cam" mode.

Note on the 'crank' (turquoise) pattern the trace rises, has a long pulse, falls, has a shorter pulse. The falling pulses on the 'cam' (green) overlap with falling pulses on the 'crank'

See sections 5.2.3 and 5.2.14.2 for mainboard modifications.

Connect crank sensor to Tach in

Connect cam sensor to Cam in

Typical settings:

Spark mode = 4G63

Trigger angle/offset = 0 (adjust with strobe)

Ignition input capture = Rising edge

Spark output = Going High

Number of coils = Wasted Spark

Most Miata/MX5 of this era use a logic wasted spark coilpack which can be directly connected to the Megasquirt.

6.19 Twin trigger



The twin-trigger mode is designed primarily for 4-cylinder bike engines using a pickup similar to the photo. There is a single tooth and two pickup coils. This allows for wasted-spark ignition.

Supported combinations include:

- Crank wheel. 4 cylinder, 4 stroke engines with wasted spark ignition, non sequential fuel.
- Crank wheel. 2 cylinder, 4 stroke engines with in wasted spark ignition, non sequential fuel.
- Cam wheel. 2 cylinder, 4 stroke engines with in coil-on-plug ignition, non sequential fuel.

This mode can be used on both even fire and odd fire engines.

If possible this setup should be replaced with a regular toothed wheel (e.g. 12-1) for more accurate timing control.

Set the mainboard as per section 5.2.2 and 5.2.14.1.

Typical settings:

Spark mode = Twin trigger

Trigger angle/offset = typically around 10deg (adjust with strobe)

Ignition input capture = Set according to whichever edge gives the most stable signal. (If timing advances with RPM, try flipping it.)

Spark output = Going high

Number of coils = Wasted Spark or Coil-on-plug

6.20 Chrysler 2.2/2.5

This setup is unique to Chrysler 2.2 and 2.5 engines from the 1980s and early 1990s, equipped with multiport injection. (The TBI versions of this engine used Basic Trigger mode instead.) It uses a four tooth cam trigger with a “window” in the middle of one tooth and two hall sensors.

Only one hall sensor is used by Megasquirt, connect to Tach in. Set the mainboard as per section 5.2.3.

Typical settings:

Spark mode = Chrysler 2.2/2.5

Trigger angle/offset = 0 (adjust with strobe)

Ignition input capture = Set according to whichever edge gives the most stable signal. (If timing advances with RPM, try flipping it.)

Spark output = Going high

Number of coils = Single coil

6.21 Renix 44-2-2 (66-2-2-2)

Known applications include:

- 1987-1990 Jeep Cherokee 4.0
- Many 1980s era Renault products

This trigger mode came in a four cylinder variation which used 44 base teeth with two gaps 180 degrees apart, and a six cylinder version with 66 base teeth and three gaps 120 degrees apart.

Typically Renault installs utilize a crank sensor only and output to a single coil and distributor.

Wasted spark or coil-on-plug require a single tooth on the cam and a cam sensor. The cam pulse needs to occur before the missing tooth region that precedes TDC#1 firing.

Typical settings:

Spark mode = Renix 44-2-2

Trigger angle/offset = 0 (adjust with strobe)

Ignition input capture = Set according to whichever edge gives the most stable signal. (If timing advances with RPM, try flipping it.)

Spark output = Going high

Number of coils = Single coil

6.22 Suzuki Swift

Known applications include:

- Suzuki Swift engines with a distributor with a VR sensor and 12 irregularly spaced teeth.

A high-current ignition driver will be required.

Typical settings:

Spark mode = Suzuki swift

Trigger angle/offset = 0 (adjust with strobe)

Ignition input capture = Set according to whichever edge gives the most stable signal. (If timing advances with RPM, try flipping it.)

Spark output = Going high

Number of coils = Single coil

6.23 Suzuki Vitara 2.0

Known applications include:

- Vitara 2.0

This variant uses an uneven crank wheel with eleven teeth.

6.24 Daihatsu 3cyl

Known applications include:

- Some 3 cylinder Daihatsu

This mode is considered experimental. The Daihatsu three cylinder version has 3 equally spaced teeth in a distributor with a fourth tooth adjacent to one of the teeth (3+1) and a VR sensor.

A high-current ignition driver will be required.

Typical settings:

Spark mode = Daihatsu 3cyl

Trigger angle/offset = 0 (adjust with strobe)

Ignition input capture = Set according to whichever edge gives the most stable signal. (If timing advances with RPM, try flipping it.)

Spark output = Going high

Number of coils = Single coil

6.25 Daihatsu 4cyl

Known applications include:

- Some 4 cylinder Daihatsu

This mode is considered experimental. The Daihatsu four cylinder version has 4 equally spaced teeth in a distributor with a fourth tooth adjacent to one of the teeth (4+1) and a VR sensor.

A high-current ignition driver will be required.

Typical settings:

Spark mode = Daihatsu 4cyl

Trigger angle/offset = 0 (adjust with strobe)

Ignition input capture = Set according to whichever edge gives the most stable signal. (If timing advances with RPM, try flipping it.)

Spark output = Going high

Number of coils = Single coil

6.26 VTR1000

Known applications include:

- Some Honda V-twin motorcycles

It uses a 12-3 crank trigger with a VR sensor and no cam sensor.

Typical settings:

Spark mode = VTR1000

Trigger angle/offset = 0 (adjust with strobe)

Ignition input capture = Set according to whichever edge gives the most stable signal. (If timing advances with RPM, try flipping it.)

Spark output = Going high

Number of coils = Wasted spark

Must also set 2 cylinders and Odd-fire.

6.27 Rover#1

Known applications include:

- Rover K-series engines

The crank trigger wheel has 36 base teeth and two one tooth gaps, 180 degrees apart. This only allows a single coil and batch fire injection. Cam input is not supported.

Typical settings:

Spark mode = Rover#1

Trigger angle/offset = 0 (adjust with strobe)

Ignition input capture = Set according to whichever edge gives the most stable signal. (If timing advances with RPM, try flipping it.)

Spark output = Going high

Number of coils = Single coil

6.28 Rover#2

Known applications include:

- Rover K-series engines

The crank trigger wheel with 36 base teeth and four one tooth gaps. This only allows a single coil or wasted spark ignition and batch fire or semi-sequential injection. Cam input is not supported.

Typical settings:

Spark mode = Rover#2

Trigger angle/offset = 0 (adjust with strobe)

Ignition input capture = Set according to whichever edge gives the most stable signal. (If timing advances with RPM, try flipping it.)

Spark output = Going high

Number of coils = Single coil or Wasted Spark

6.29 Rover#3

Known applications include:

- Rover K-series engines

Similar to Rover #2, but the gaps are two teeth wide and positioned differently. As with Rover #2, supports wasted spark and semi-sequential injection, but does not support cam input.

Typical settings:

Spark mode = Rover#3

Trigger angle/offset = 0 (adjust with strobe)

Ignition input capture = Set according to whichever edge gives the most stable signal. (If timing advances with RPM, try flipping it.)

Spark output = Going high

Number of coils = Single coil or Wasted Spark

6.30 GM7X

Known applications include:

- Some GM four and six cylinder engines with distributorless ignitions.

GM refers to the crank wheel in their internal documentation as a 7X trigger wheel. It has six equally spaced teeth and a seventh tooth for cylinder identification.

The cam input is supported for sequential fuel and spark and VVT (may require 1.4.x firmware.)

Typical settings:

Spark mode = GM7X

Trigger angle/offset = 0 (adjust with strobe)

Ignition input capture = Set according to whichever edge gives the most stable signal. (If timing advances with RPM, try flipping it.)

Spark output = Going high

Number of coils = Wasted Spark

6.31 QR25DE

Known applications include:

- Nissan QR25DE and some other Nissan four cylinders.

Requires crank and cam sensors to be connected.

6.32 Honda RC51

Known applications include:

- Honda RC51, RC46, FSC600 and many CBR variants
- AP1 Honda S2000

This one uses a 12 tooth crank trigger and 3 tooth cam trigger, with VR sensors on both.

RC51 is 2 cyl odd-fire.

FSC600 is 2 cyl even-fire.

RC46 is 4 cyl odd-fire.

6.33 GM LS1 (24X)

Known applications include:

- Chevrolet V8s of LS1 family using a 24X crank pattern. (Typically Gen 3.)

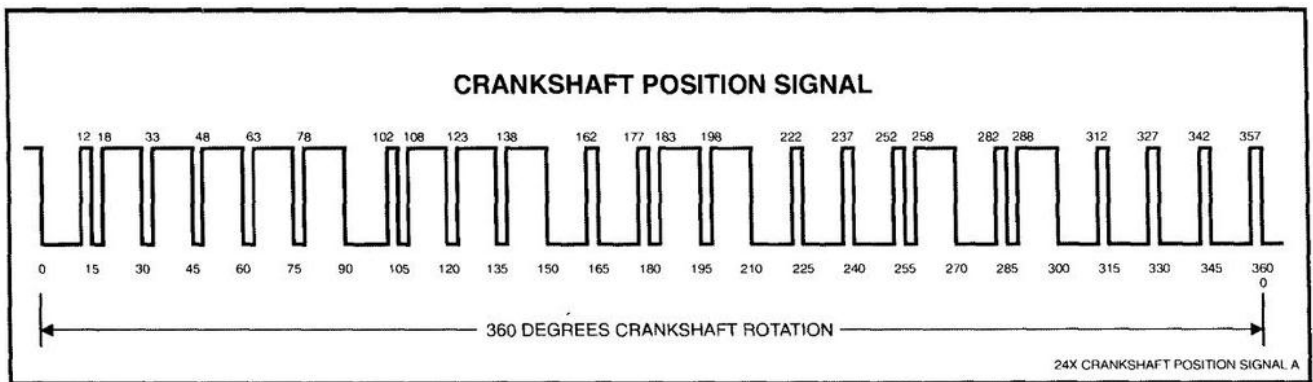

Crankshaft Position Sensor Signal

Only the crank sensor is used with Megasquirt-3 without MS3X.

Set the mainboard as per section 5.2.4.

24X (black) crank sensor

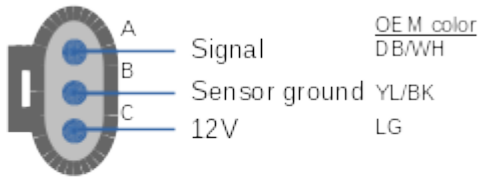

24X (black) cam sensor

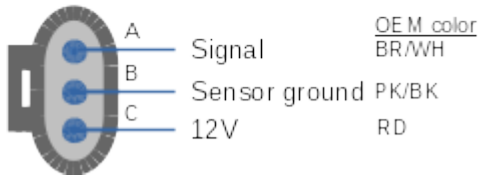

Mainboard customisation is required for four logic spark outputs. It is preferable to use the MS3X on the 24X engine as it gives full sequential and a more straightforward install.

The coils are wired in pairs SpkA = 1&6, SpkB = 8&5, SpkC = 7&4, SpkD = 2&3

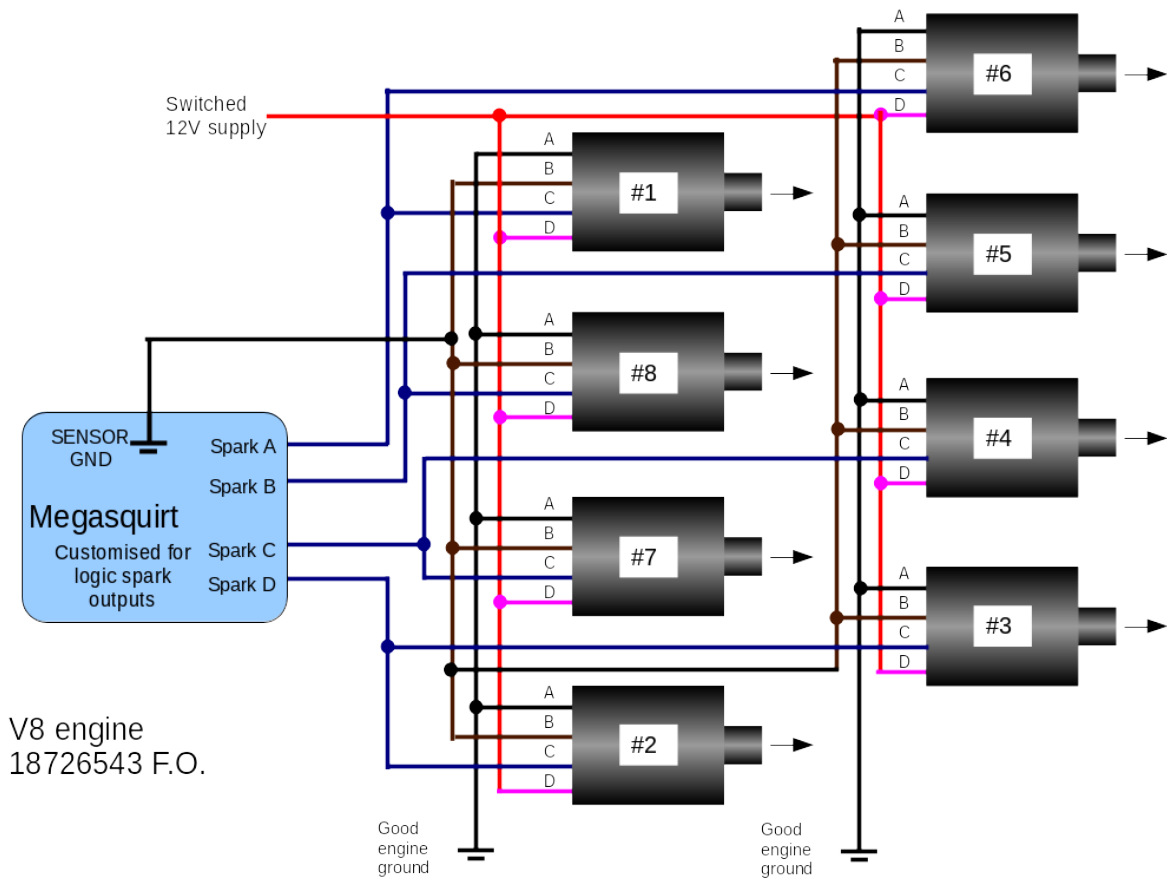

Typical settings:

Spark mode = LS1

Trigger angle/offset = 0 (adjust with strobe)

Ignition input capture = Rising edge

Spark output = Going high

Number of coils = Wasted spark

6.34 GM LS2 (58X)

Known applications include:

- Chevrolet V8s of LS2 family using a 58X crank pattern. (Typically Gen 4.)

Only the crank sensor is used with Megasquirt-3 without MS3X.

Set the mainboard as per section 5.2.3.

58X (gray) crank sensor

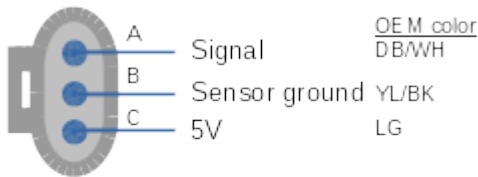

58X (gray) cam sensor

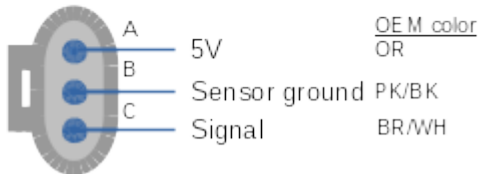

Mainboard customisation is required for four logic spark outputs. It is preferable to use the MS3X on the 58X engine as it gives full sequential and a more straightforward install.

The coils are wired as shown in section 6.33

Typical settings:

Spark mode = Toothed wheel

Ignition input capture: Rising edge

Spark output: Going High

Number of coils = Wasted Spark

Trigger wheel arrangement = Single wheel with missing tooth

Trigger wheel teeth = 60

Missing teeth = 2

Tooth #1 angle = 84 (adjust with strobe)

Main wheel speed = Crank wheel

6.35 YZF1000

Known applications include:

- Yamaha YZF1000 / Thunderace
- Yamaha FZR1000
- Yamaha FZR750
- Yamaha FZ700

Typical settings:

Spark mode = YZF1000

Trigger angle/offset = 0 (adjust with strobe)

Ignition input capture = Falling edge

Spark output = Going high

6.36 HD 32-2

Known applications include:

- Harley Davidson with 32-2 crank trigger

A VR sensor is used on the crank trigger. As standard there is no cam sensor. Phase detection is possible using the MAP sensor.

Typical settings:

Spark mode = HD 32-2

Trigger angle/offset = 0 (adjust with strobe)

Ignition input capture = Set according to whichever edge gives the most stable signal. (If timing advances with RPM, try flipping it.)

Spark output = Going high

Cam sensor = MAP

The front cylinder is considered cyl#1 and therefore connects to SpkA. Sequential fuel is allowed.

6.37 Miata 36-2

Known applications include:

- Mazda Miata (MX5) 99-05 fitted with aftermarket 36-2 crank trigger

Typical settings:

Spark mode = Miata 36-2

Trigger angle/offset = 0 (adjust with strobe)

Ignition input capture = Set according to whichever edge gives the most stable signal. (If timing advances with RPM, try flipping it.)

Spark output = Going high

Both crank and cam sensors are VR type and need to be connected.

6.38 Fiat 1.8 16V

Known applications include:

- Fiat with 1.8 16V engine

Typical settings:

Spark mode = Fiat 1.8 16V

Trigger angle/offset = 0 (adjust with strobe)

Ignition input capture = Set according to whichever edge gives the most stable signal. (If timing advances with RPM, try flipping it.)

Spark output = Going high

Uses an irregular six tooth crank trigger and a three tooth cam trigger, with a VR crank trigger and Hall effect cam signal. Both sensors need to be connected.

Set the mainboard as per section 5.2.2 and 5.2.14.2.

6.39 GM Optispark

Known applications include:

- Chevrolet LT1 variants
- Nissan VH45 V8

The Optispark system was used on GM vehicles from 1993 to 1997 on LT1, LT4 and L99 applications. Internally it uses a Mitsubishi / Nissan derived optical trigger arrangement. There is a "hi-res" track of 360 slits and a "low-res" track of 8 slots of varying length. The pickup design is sound, but the high-tension side can be problematic with the "correct-a-cap" design - especially if a high energy aftermarket ignition system is used.

The Megasquirt-3 Optispark decoder uses both low and high resolution tracks for improved ignition accuracy. (Most other aftermarket implementation only use the low resolution track.) The system allows for sequential fuel and the single coil as per the original install. However, as an enhancement the single coil can be replaced by a wasted-spark or coil-on-plug setup which would eliminate the troublesome high-tension cap.

The Optispark requires a fused 12V supply. This can be tapped into the same 12V supply as the Megasquirt. The Ground connection should be run to the sensor ground at the Megasquirt.

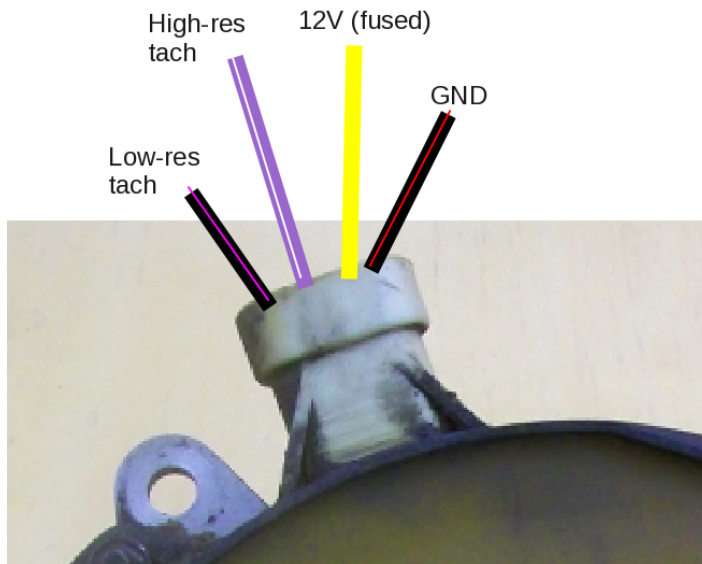

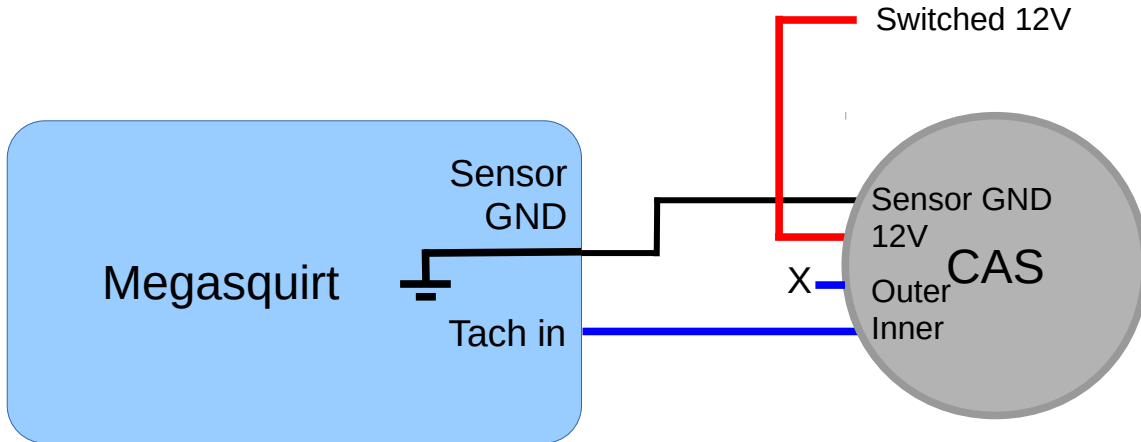

Set the mainboard as per section 5.2.3

Typical settings:

Spark mode = Basic Trigger

Trigger angle/offset = Start at 10 deg - adjust while strobing timing.

Ignition input capture = Falling edge

Number of coils = Single coil

6.40 Nissan SR20

This is not covered as full sequential requires input PT4 to be connected through the MS3X.

6.41 Nissan RB25

This is not covered as full sequential requires input PT4 to be connected through the MS3X.

6.42 Honda Acura V6

Known applications include:

- Honda and Acura J series V6 motors.

This mode uses a crank trigger with 24 base teeth and two separate missing teeth, along with a cam sensor.

Typical settings:

Spark mode = Honda Acura

Trigger angle/offset = 0 (adjust with strobe)

Ignition input capture = Set according to whichever edge gives the most stable signal. (If timing advances with RPM, try flipping it.)

Spark output = Going high

6.43 VQ35DE

Known applications include:

- Nissan 350Z and other VQ35DE applications

Requires crank and cam sensors to be connected.

Typical settings:

Spark mode = VQ35DE

Trigger angle/offset = 0 (adjust with strobe)

Ignition input capture = Set according to whichever edge gives the most stable signal. (If timing advances with RPM, try flipping it.)

Spark output = Going high

6.44 Jeep 2000

Known applications include:

- 1991-2000 Jeep 4.0 inline six
- Dodge Avenger 2.5 V6
- Some Chrysler V6 minivans

This mode has three sets of four notches on the crank trigger and a one tooth distributor trigger.

Requires crank and cam sensors to be connected.

Typical settings:

Spark mode = Jeep 2000

Trigger angle/offset = 0 (adjust with strobe)

Ignition input capture = Set according to whichever edge gives the most stable signal. (If timing advances with RPM, try flipping it.)

Spark output = Going high

6.45 Jeep 2002

Known applications include:

- 3.7 V6

This mode appears on the last run of the Jeep 4.0 inline six, with coil packs instead of the distributor. Uses the same crank trigger as the Jeep 2000 mode, but with a more complex cam pattern.

Requires crank and cam sensors to be connected.

Typical settings:

Spark mode = Jeep 2002

Trigger angle/offset = 0 (adjust with strobe)

Ignition input capture = Set according to whichever edge gives the most stable signal. (If timing advances with RPM, try flipping it.)

Spark output = Going high

6.46 Zetec VCT

Known applications include:

- 3.7 V6

Used on Ford Zetec and other four cylinder engines with variable valve timing. Features a 36-1 crank trigger like many other Fords, but a five tooth cam wheel instead of a one tooth. Uses VR sensors on both, and supports full sequential operation and variable valve timing.

Requires crank and cam sensors to be connected.

Typical settings:

Spark mode = Zetec VCT

Trigger angle/offset = 0 (adjust with strobe)

Ignition input capture = Set according to whichever edge gives the most stable signal. (If timing advances with RPM, try flipping it.)

Spark output = Going high

6.47 Flywheel tri-tach

Known applications include:

- Early 1980s Porsche 911
- Porsche 944 Turbo (951)
- 1986 and earlier BMW 325e
- E30 chassis BMW M3 with S14 motor
- Many 1980s and early 1990s Audis

This application uses a VR sensor that counts flywheel teeth, with a second flywheel sensor that reads a single post and, in most implementations, a cam sensor. Note that the number of teeth is hard coded for a specific number of cylinders. With a cam sensor, this will support full sequential.

Most installs require three tach inputs

- flywheel tooth sensor (VR)
- flywheel reset pin sensor (VR)
- distributor sensor (hall)

This mode is considered experimental.

Number of teeth	Number of cylinders
135	5
135	6
136	8
132	4
130	4

Typical settings:

Spark mode = Flywheel tri-tach

Trigger angle/offset = 0 (adjust with strobe)

Ignition input capture = Set according to whichever edge gives the most stable signal. (If timing advances with RPM, try flipping it.)

Spark output = Going high

6.48 2JZ VVTi

Known applications include:

- Lexus IS300
- many 2000 and later Toyota six cylinder engines with VVTi.

This uses a 36-2 crank trigger and a three tooth cam trigger, with VR sensors. Supports sequential injection and variable valve timing.

Both sensors need to be connected for VVT.

Typical settings:

Spark mode = 2JZVVTi

Trigger angle/offset = 0 (adjust with strobe)

Ignition input capture = Set according to whichever edge gives the most stable signal. (If timing advances with RPM, try flipping it.)

Spark output = Going high

6.49 Honda TSX/D17

Known applications include:

- D17 engine

Uses a 12 tooth crank sensor with one tooth added for a total of 13 real teeth, combined with a cam sensor. This allowed Honda to add continuously variable valve timing. Uses VR sensors.

Both sensors need to be connected for VVT.

Typical settings:

Spark mode = Honda TSX/D17

Trigger angle/offset = 0 (adjust with strobe)

Ignition input capture = Set according to whichever edge gives the most stable signal. (If timing advances with RPM, try flipping it.)

Spark output = Going high

6.50 Mazda6 2.3 VVT

Known applications include:

- Mazda 6 with VVT

This one has a 36-1 crank trigger and an uneven cam pattern.

Typical settings:

Spark mode = Mazda6 VVT

Trigger angle/offset = 0 (adjust with strobe)

Ignition input capture = Set according to whichever edge gives the most stable signal. (If timing advances with RPM, try flipping it.)

Spark output = Going high

6.51 Viper V10 (gen 2)

Known applications include:

- 1996 and later Vipers and V10 Rams with JTEC ECU

This one has a crank trigger with five groups of two teeth. A cam sensor is also required, with a one tooth trigger wheel.

Coil-on-plug is beyond the scope without MS3X, so wasted spark should be used.

Factory Chrysler coils are high-current type and require internal or external ignitors.

Typical settings:

Spark mode = Viper V10

Trigger angle/offset = 0 (adjust with strobe)

Ignition input capture = Set according to whichever edge gives the most stable signal. (If timing advances with RPM, try flipping it.)

Spark output = Going high

6.52 Viper V10 (gen 1)

Known applications include:

- 1995 and earlier Vipers and V10 Rams.

This one has a crank trigger with five groups of two teeth. A cam sensor is also required, with a one, two tooth trigger wheel.

Coil-on-plug is beyond the scope without MS3X, so wasted spark should be used.

Factory Chrysler coils are high-current type and require internal or external ignitors.

Typical settings:

Spark mode = Viper V10 Gen1

Trigger angle/offset = 0 (adjust with strobe)

Ignition input capture = Set according to whichever edge gives the most stable signal. (If timing advances with RPM, try flipping it.)

Spark output = Going high

6.53 Honda K24A2

Known applications include:

- Honda K24A2

This works very similarly to the TSX/D17 mode, but the crank phasing is different.

Typical settings:

Spark mode = K24A2

Trigger angle/offset = 0 (adjust with strobe)

Ignition input capture = Set according to whichever edge gives the most stable signal. (If timing advances with RPM, try flipping it.)

Spark output = Going high

7: Throttles

The major influence on engine speed on a spark-ignition (gasoline) engine is air-flow. (Contrast a compression-ignition (diesel) engine where there is no throttling and fuel flow governs engine speed.)

For normal running the main throttle plates control the air-flow. At idle an idle valve can be used to provide controlled flow, or a throttle stop screw can be used on the main throttles to allow a low flow during "closed" throttle conditions.

Throttles need to be appropriately sized for the engine displacement and RPM range. Too small and the engine will "run out of steam" at higher RPMs. Too large and tiny throttle movement will allow a large airflow giving jerky low-load operation.

There are a wide range of throttles available. Most factory EFI installs use a single throttle plate. Many aftermarket companies offer USA style 4 barrel carburettor replacement throttle-bodies. Another option that is particularly common on 4-cylinder engines is to fit bike throttle bodies.

Independent throttle body installs free up the most power from the engine, but will need to be balanced (equal airflow for each throttle) and the MAP signal will be weak - consider using "ITB mode" or "Alpha-N."

All throttles will need to be fitted with a TPS if not already included.

Example 4150 style 4-barrel EFI throttle body.



8: Optional Hardware

8.1 Expansion boards

The Megasquirt was designed with enough inputs and outputs to control a simple engine. If additional inputs and outputs are desired, an add-on expansion board may be used.

The Megasquirt has CAN communications that allow the simple 2-wire connection.

Example expansion boards are:

- CANEGT - allows K-type thermocouples for per-cylinder exhaust gas temperature monitoring
- GPIO/ trans - allows control of electronically shifted automatic transmissions
- IO-Expander - DIY assembled product for additional analogue input, relay outputs, GPS, accelerometer, thermocouple.
- Dashes / loggers - many vendors dashboards are compatible with the Megasquirt-2 data stream.

For specific product features and configuration details, please refer to your supplier's documentation.

9: Example wiring

9.1 Nitrous

The following layout shows typical wiring for a wet nitrous system. It is drawn using "PE0" as the ground-switched input and IAC1/2 as the stage 1 and 2 outputs.

With the appropriate software settings other pins may be used for inputs and/or FIDLE+D15 may be used as the outputs.

MS2/Extra nitrous control

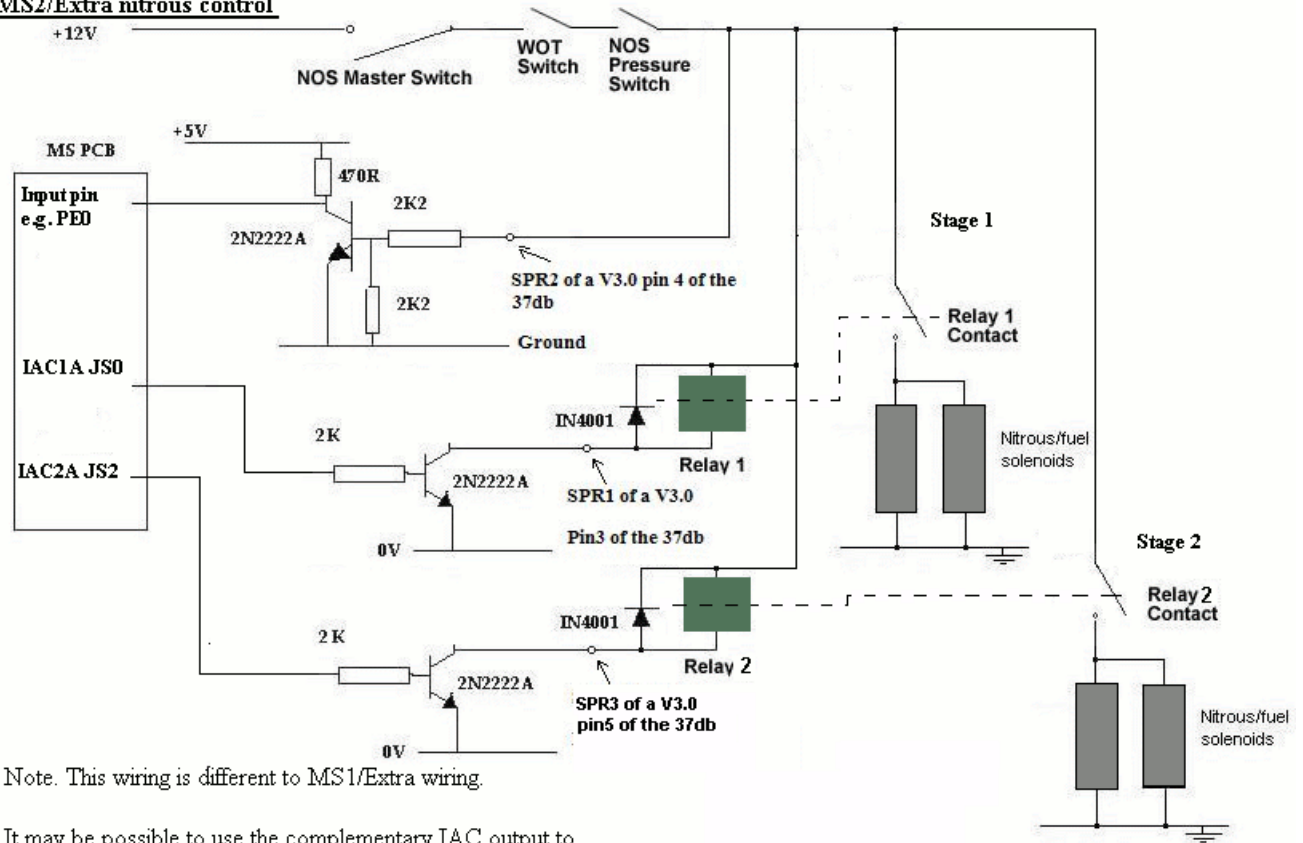

Note. This wiring is different to MS1/Extra wiring.

It may be possible to use the complementary IAC output to directly drive a relay as long as the 750mA limit is not exceeded. DB37 pins are examples only.

9.2 Component pinouts

The following are some typical component pinouts that may be of use while adding additional circuits.

Diagrams / layout of components used in some of the MSnS-Extra hardware mod's

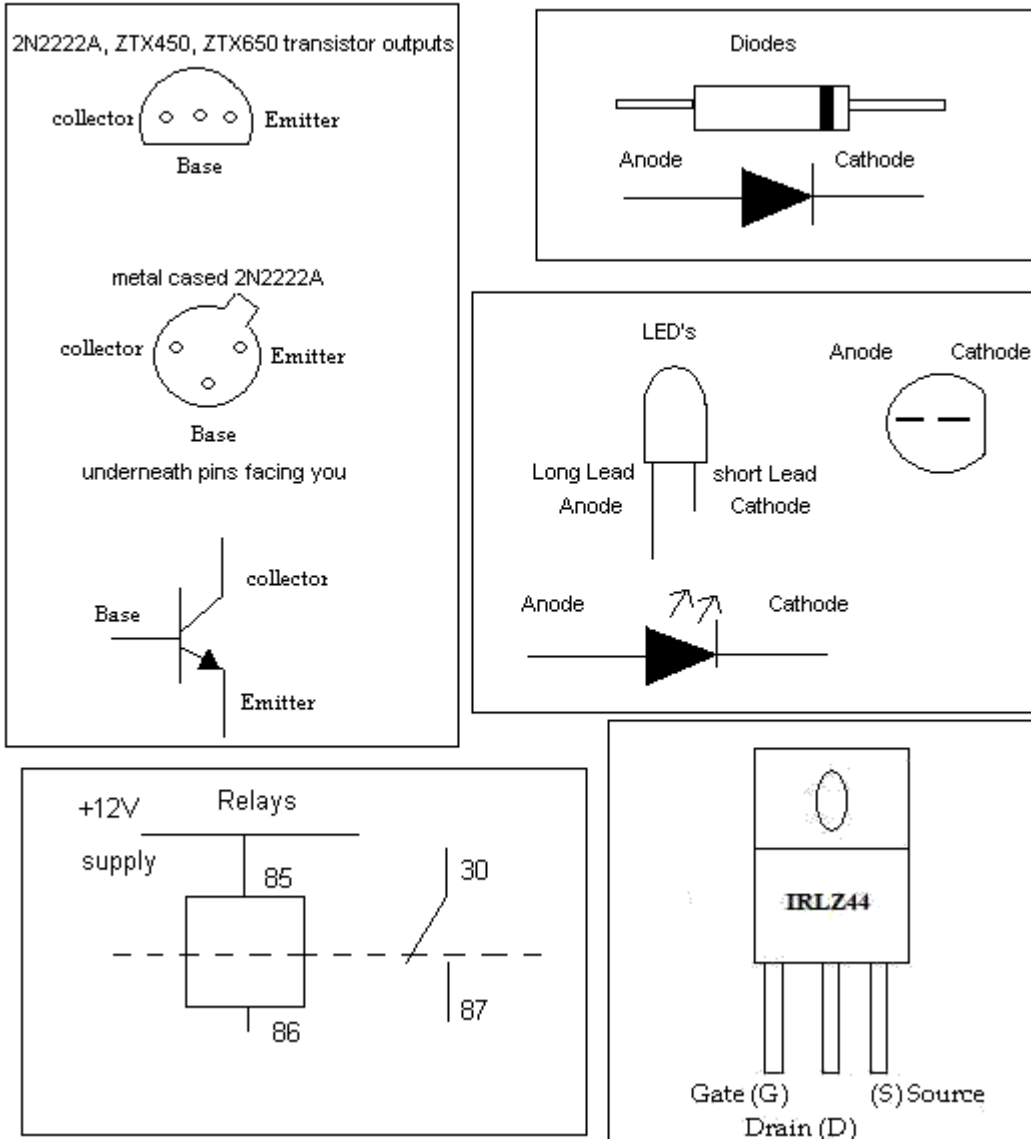

10: Further information

For additional information or to join the community forums for Megasquirt, please visit:

www.msextra.com

11: Appendix A Schematics

The copyrighted Megasquirt schematics are provided for repair, interfacing and education purposes only.

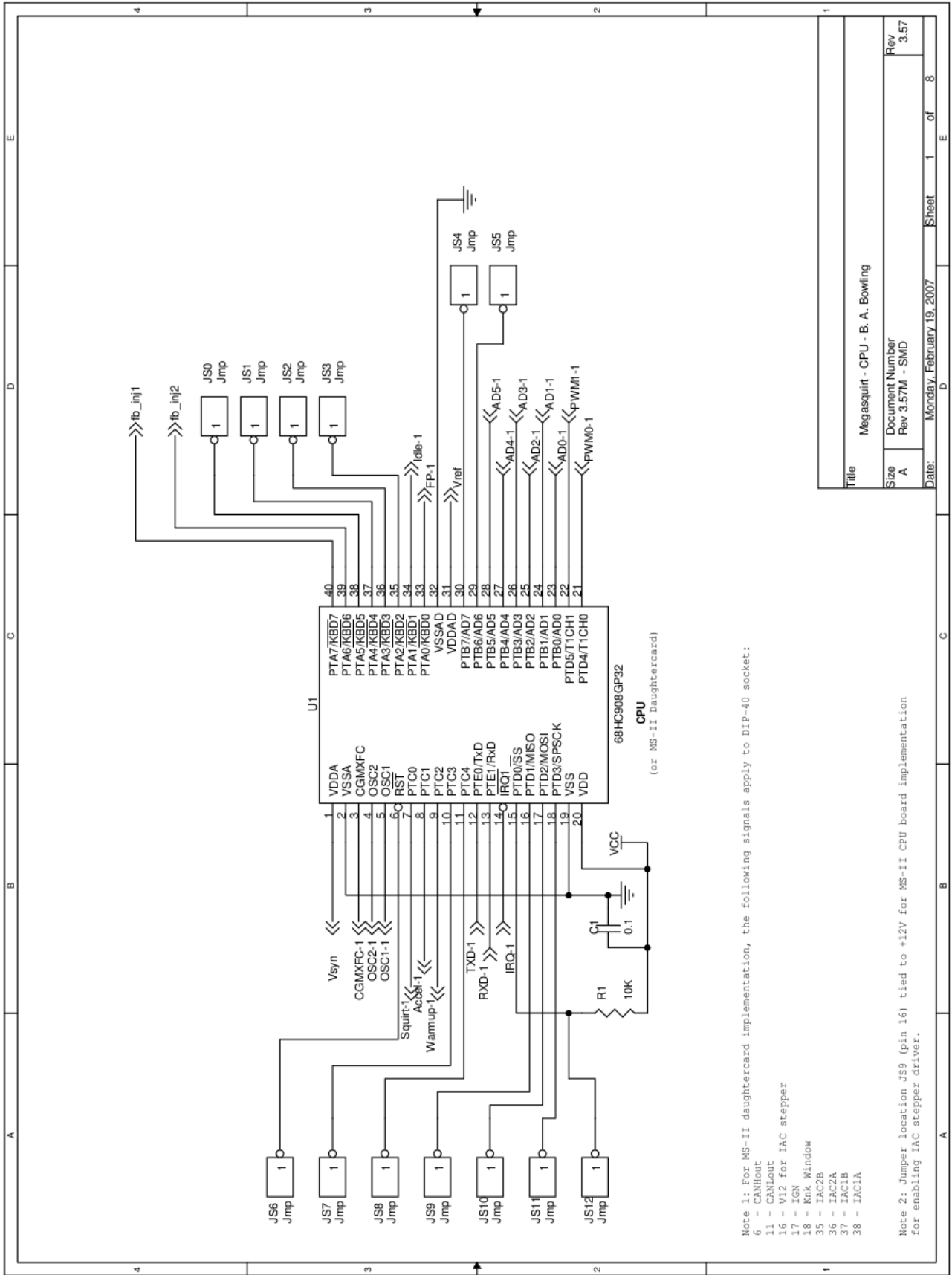

Note 1: For MS-II daughtercard implementation, the following signals apply to DIP-40 socket:

- 6 - CANROUT
- 11 - CANROUT
- 16 - VIZ for IAC stepper
- 17 - IGN
- 18 - Kmk Window
- 35 - IAC2B
- 36 - IAC2A
- 37 - IAC1B
- 38 - IAC1A

Note 2: Jumper location JS9 (pin 16) tied to +12V for MS-II CPU board implementation for enabling IAC stepper driver.

Title		Megasquirt - CPU - B. A. Bowling	
Size	A	Document Number	Rev 3.57M - SMD
Date:	Monday, February 19, 2007	Sheet	1 of 8

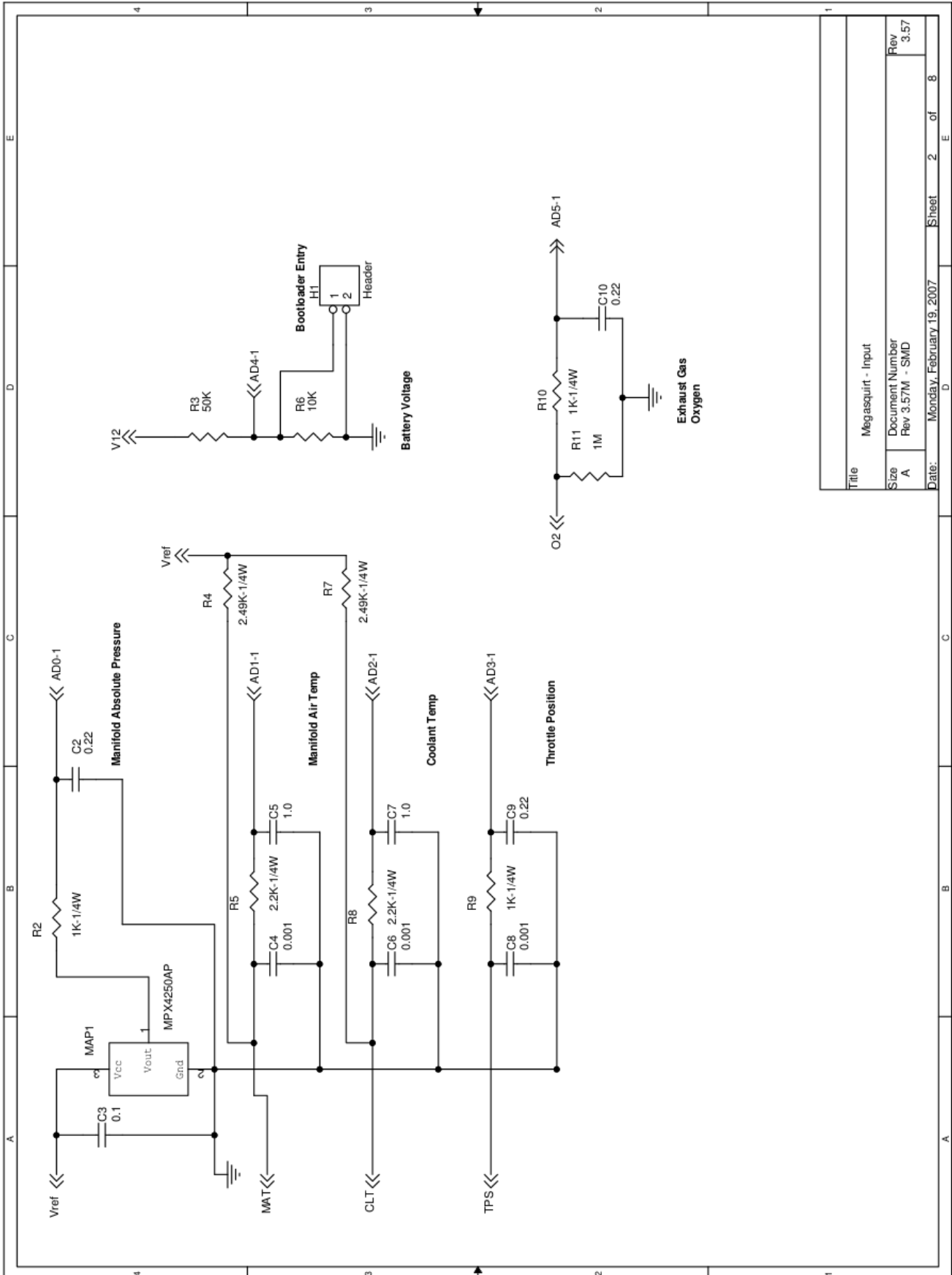

Title		Megasquirt - Input	
Size	A	Document Number	Rev 3.57M - SMD
Date:	Monday, February 19, 2007	Sheet	2 of 8

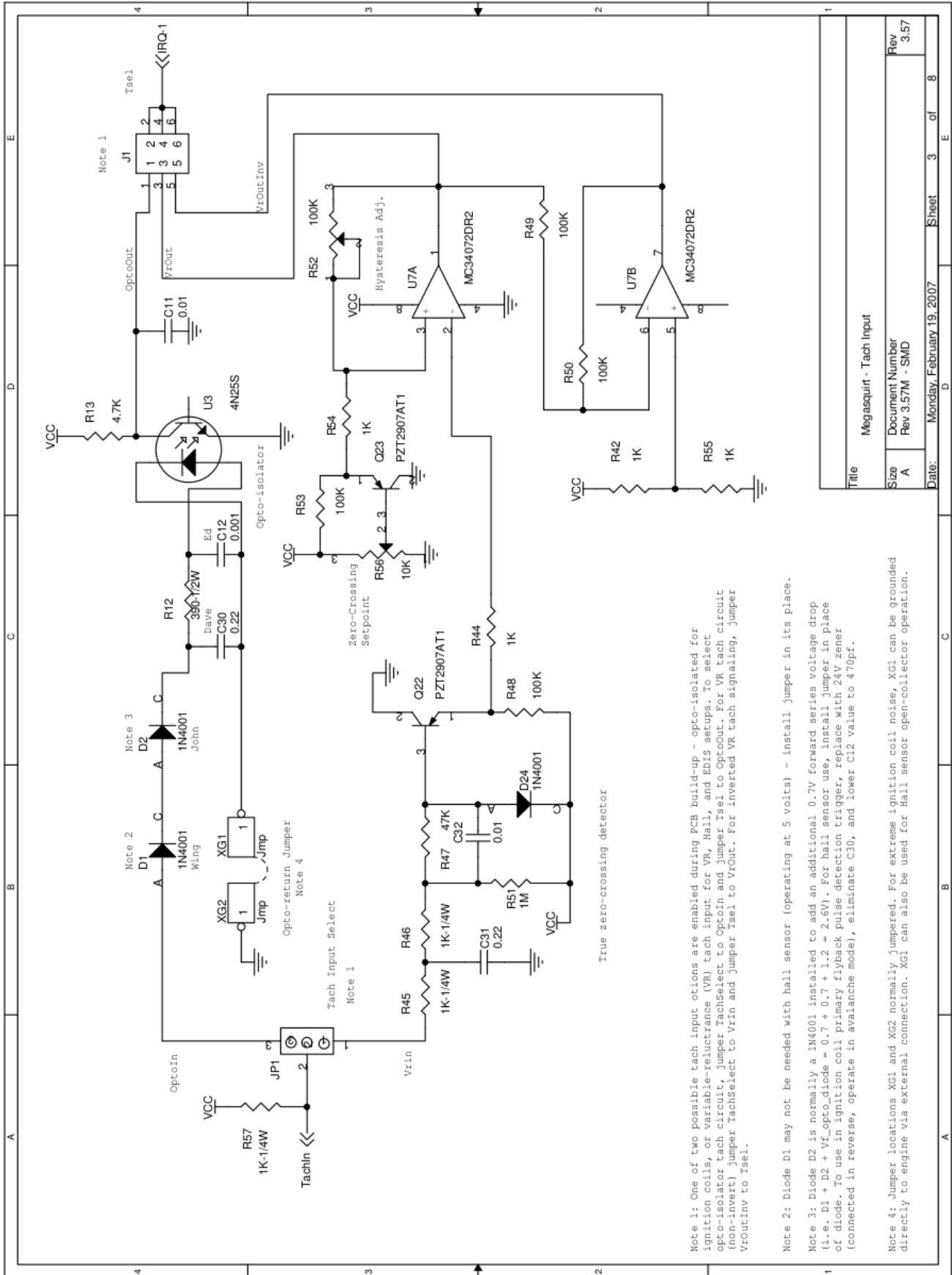

Note 1: One of two possible tach input options are enabled during PCB build-up - opto-isolated for ignition coils, or variable-reluctance (VR) tach input for VR, Hall, and EDIS setups. To select opto-isolator tach circuit, jumper TachSelect to Optoin and Jumper Tsel1 to OptoOut. For VR tach circuit (non-invert) jumper TachSelect to VrIn and Jumper Tsel1 to VrOut. For inverted VR tach signaling, jumper VrOutInvt to Tsel1.

Note 2: Diode D1 may not be needed with hall sensor (operating at 5 volts) - install jumper in its place.

Note 3: Diode D2 is normally a 1N4001 installed to add an additional 0.7V forward series voltage drop (i.e. $D1 + D2 + V_f(\text{opto_diode}) = 0.7 + 0.7 + 1.2 + 2.6V$). For hall sensor use, install jumper in place of diode. To use in ignition coil primary flyback pulse detection trigger, replace with 24V zener (connected in reverse, operate in avalanche mode), eliminate C30, and lower C12 value to 470pf.

Note 4: Jumper locations XG1 and XG2 normally jumpered. For extreme ignition coil noise, XG1 can be grounded directly to engine via external connection. XG1 can also be used for Hall sensor open-collector operation.

Title		Megasquirt - Tach Input	
Size	Document Number	Rev	Rev
A	Rev 3.57M - SMD	3	5.57
Date:	Monday, February 19, 2007	Sheet	3 of 8

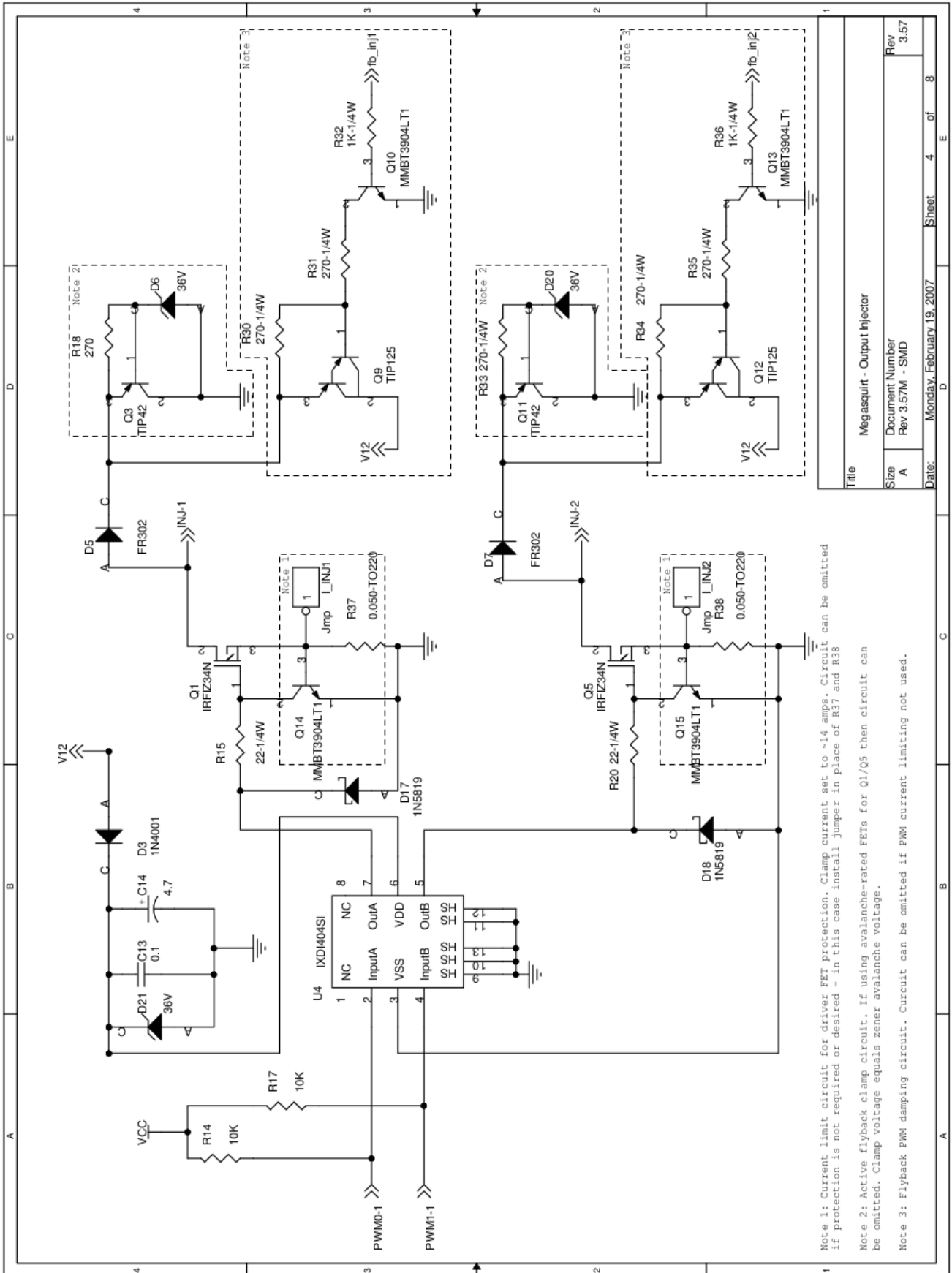

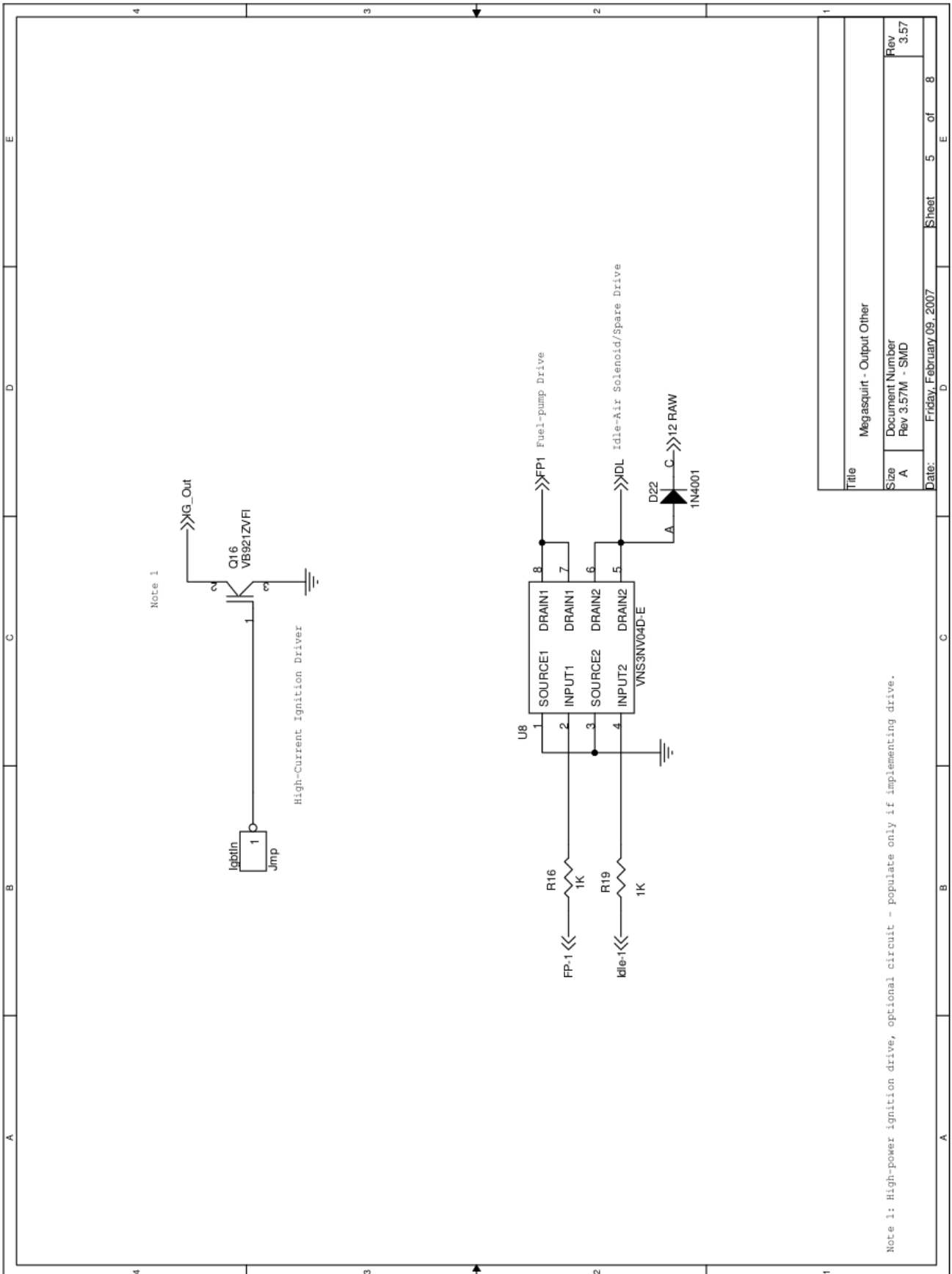

Note 1: High-power ignition drive, optional circuit - populate only if implementing drive.

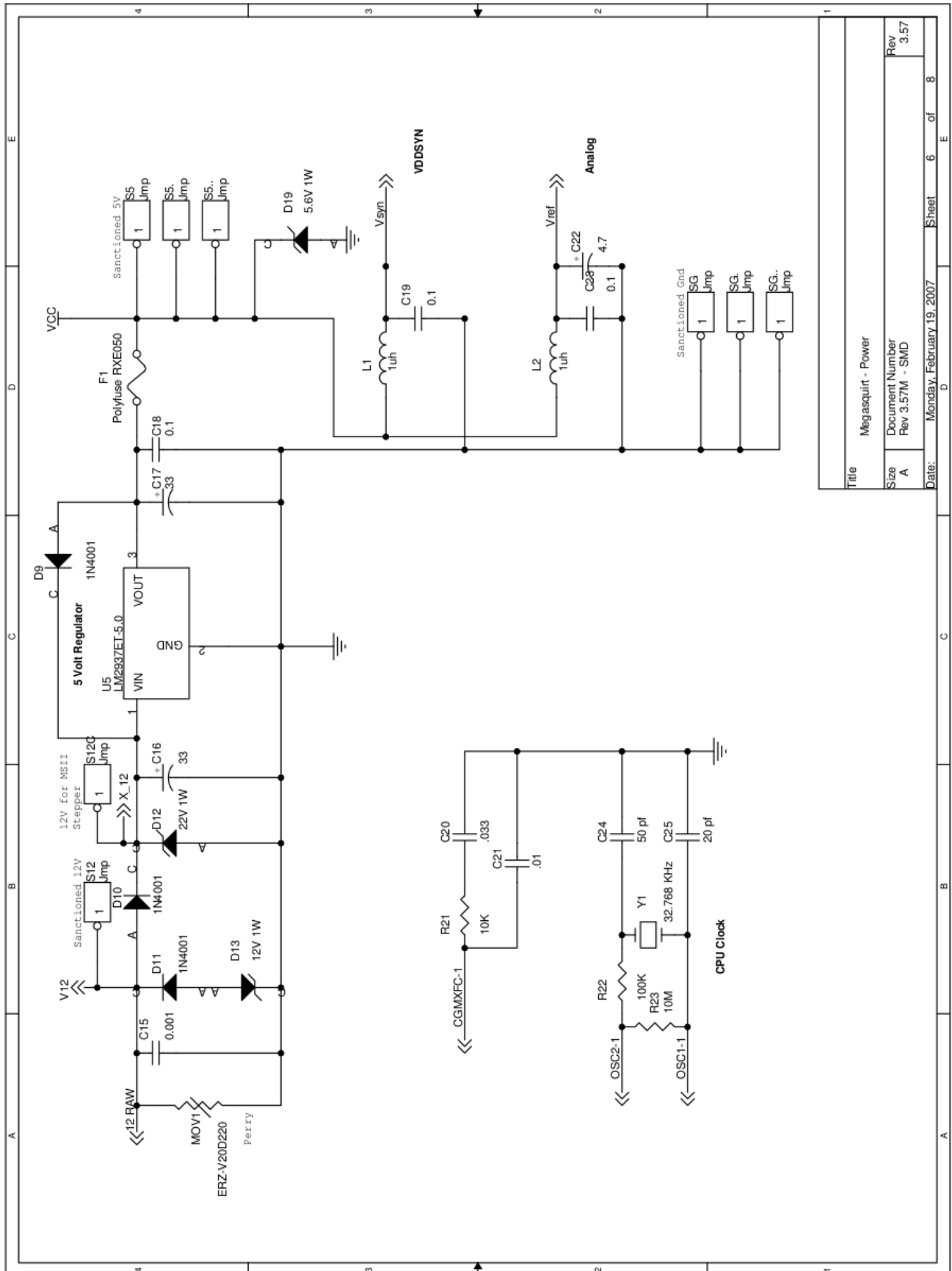

Title		Megasquirt - Power
Size	Document Number	Rev
A	Rev 3.57M - SMD	3.57
Date:	Monday, February 19, 2007	Sheet 6 of 8

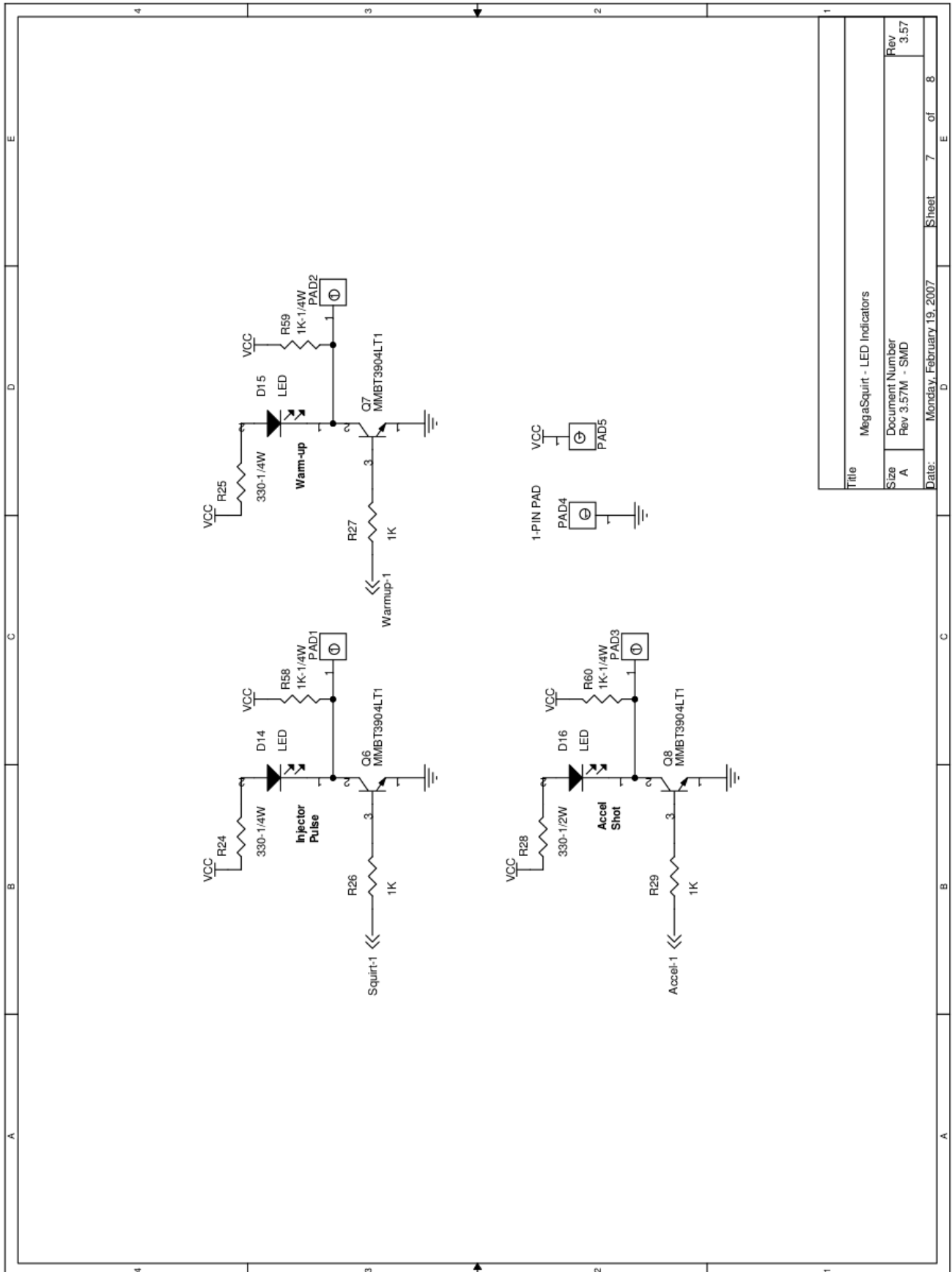

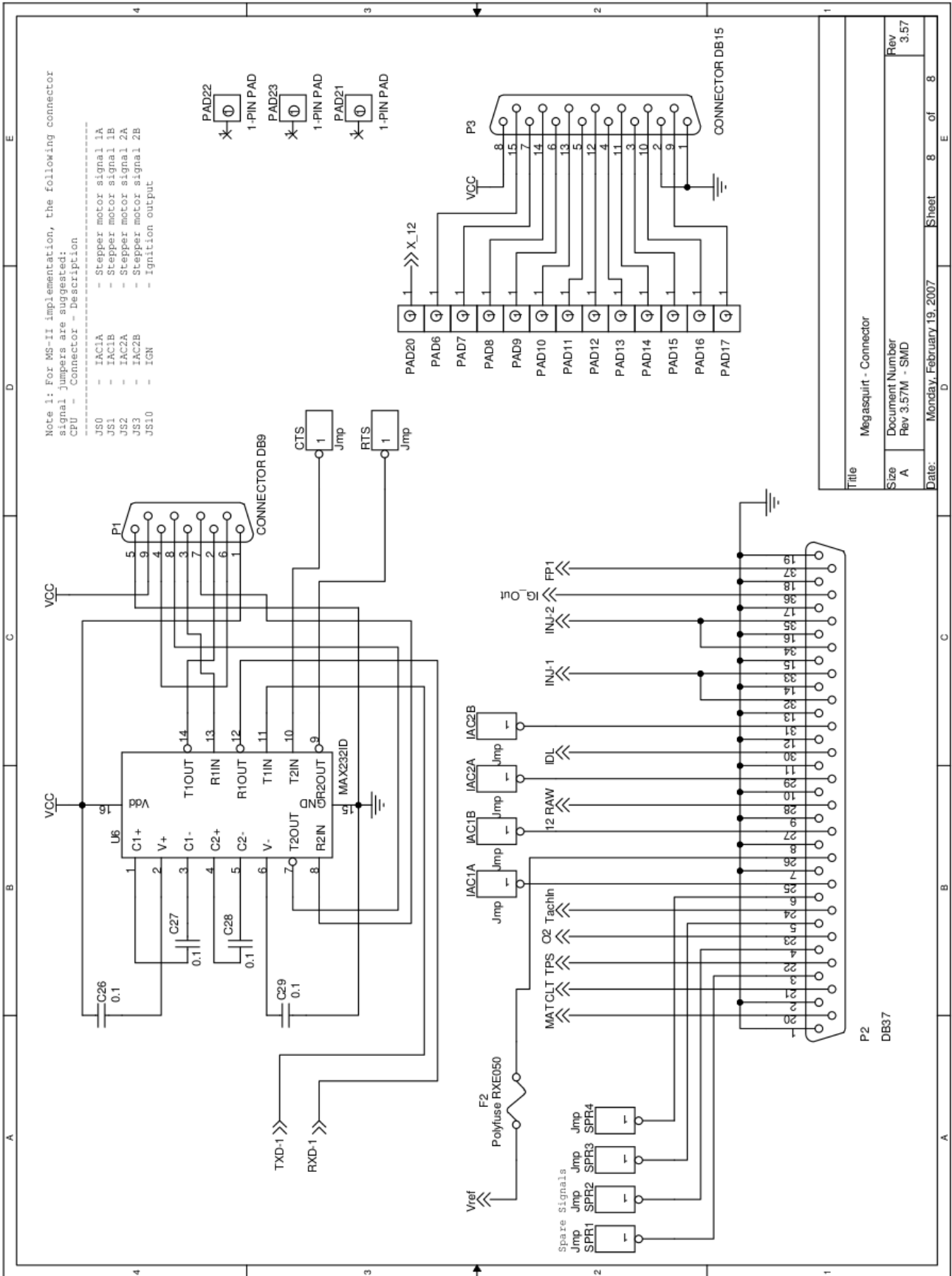

Title	Megasquirt - Connector
Size	A
Document Number	Rev 3.57M - SMD
Rev	3.57
Date:	Monday, February 19, 2007
Sheet	8 of 8

There are no plans to publish the schematics for the MS3 card.

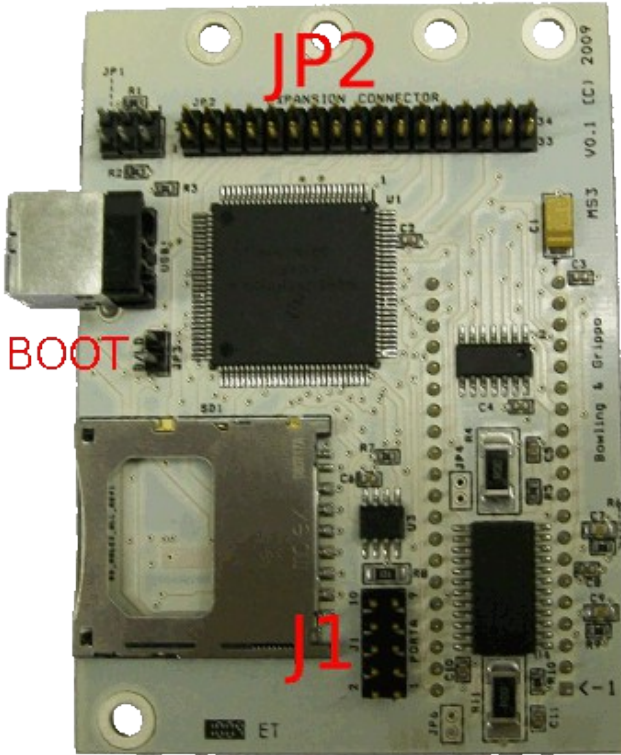

JP2

2	PE2 - Flex
4	PB7 - SpkH
6	PB6 - SpkG
8	PB4 - SpkE
10	PB2 - SpkC
12	PB0 - SpkA
14	AN12 - EGO2
16	PT6 - Datalog in
18	PT2 - Cam in
20	PK1 - (spare)
22	PK3 - (spare)
24	PP3 - Boost
26	PP5 - Nitrous2
28	GND
30	GND
32	GND
34	12V

Table sw. in - PH6 1
 Nitrous in - PH7 3
 SpkF - PB5 5
 SpkD - PB3 7
 SpkB - PB1 9
 EXT_MAP - AN11 11
 SPARE_ADC - AN13 13
 PT4 - PT4 15
 Tacho - PK0 17
 Launch in - PK2 19
 Idle - PP2 21
 Nitrous 1 - PP4 23
 VVT - PP6 25
 (spare) - PM2 27
 (spare) - PK7 29
 5V 31
 12V 33

J1

10	GND
8	InjH - PA7
6	InjF - PA5
4	InjD - PA3
2	InjB - PA1
9	GND
7	PA6 - InjG
5	PA4 - InjE
3	PA2 - InjC
1	PA0 - InjA

Relay Board

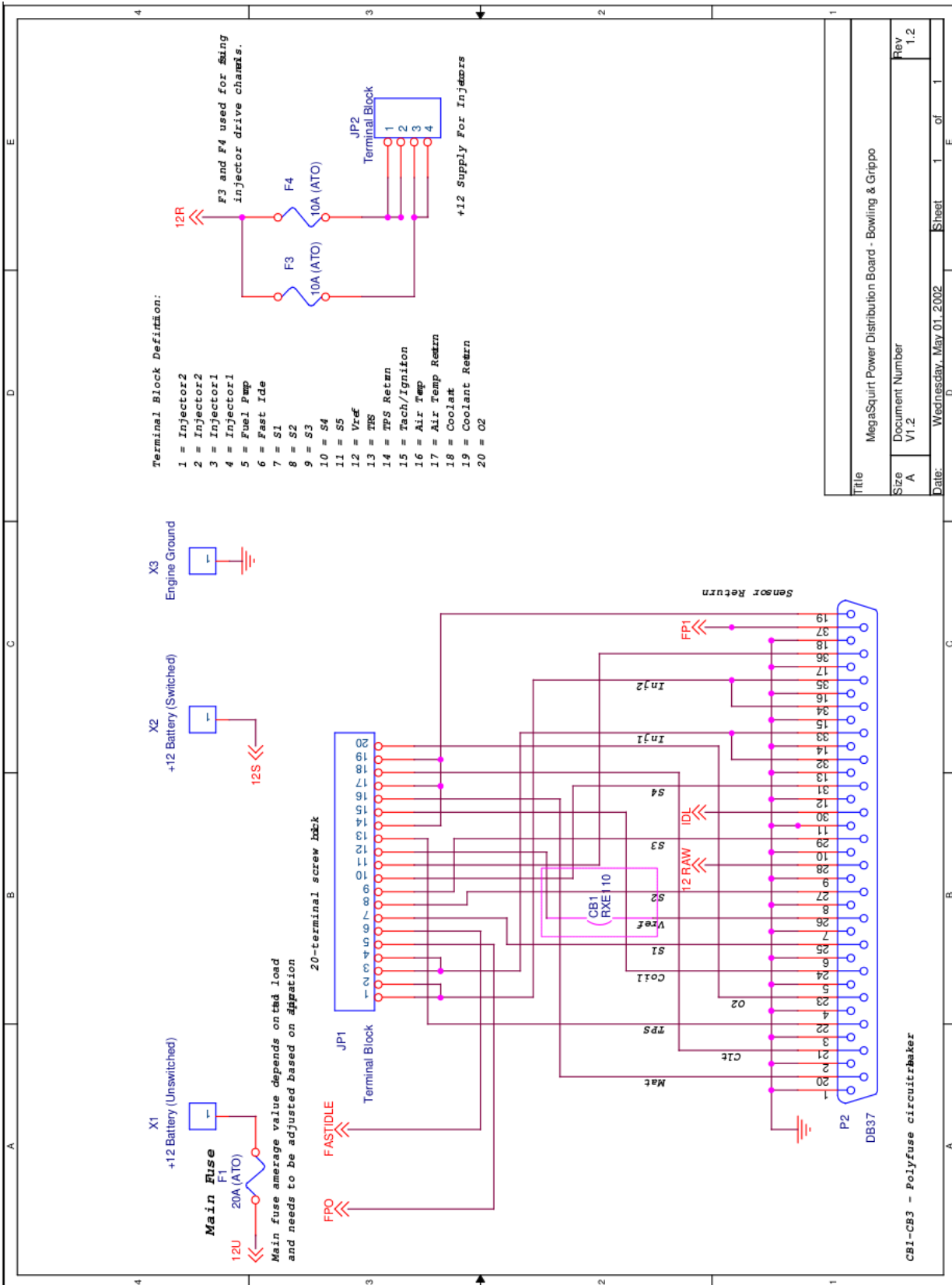

Title		MegaSquirt Power Distribution Board - Bowling & Grippo	
Size	Document Number	Rev	Rev
A	V1.2	1.2	1.2
Date:	Wednesday, May 01, 2002	Sheet	1 of 1

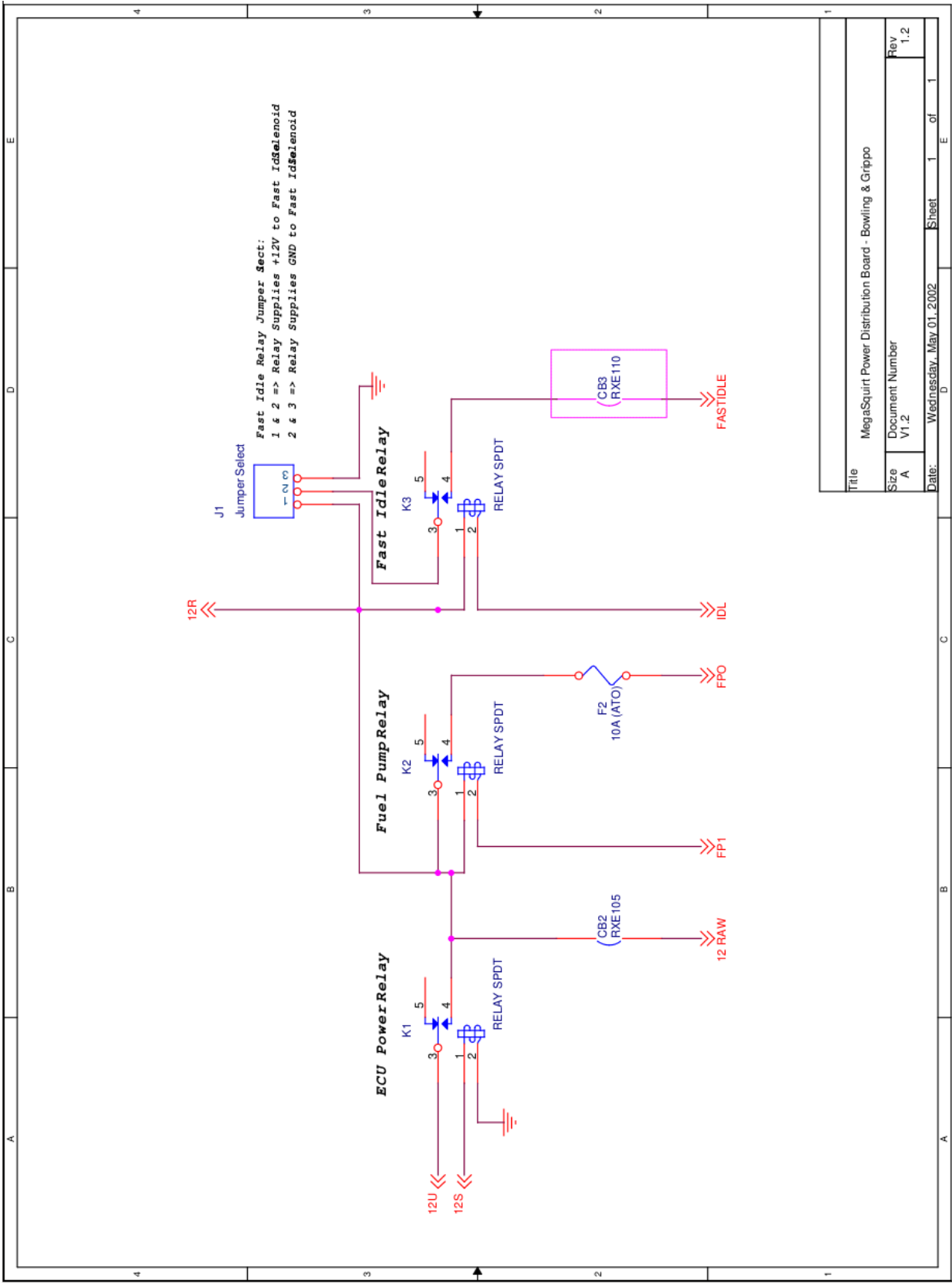

Title		MegaSquirt Power Distribution Board - Bowling & Grippo	
Size	Document Number	Rev	Rev
A	V1.2	1.2	1.2
Date:	Wednesday, May 01, 2002	Sheet	1 of 1

12: Appendix B: junkyard guide to finding EDIS

12.1 North America - EDIS4

Early to mid 1990s Ford Escort/ Mercury Tracer with base 1.9L SOHC engine were fitted with the EDIS4 system. You can tell the engine because it has a tubular aluminium (NOT cast) inlet manifold.

The EDIS4 module is mounted just behind the fuse box on the drivers side of the engine bay, it has a label on the plug that says EDIS4. The bolts are 10mm AF. You are advised to remove the fuse box first for easier access. Cut off as much of the harness as you can.

Looking toward the passenger side end of the engine, the VR sensor is above and to the left of the end of the crankshaft. The easiest way to access the sensor is to remove the front wheel (if it's not already removed), lie on your back, and reach up from the bottom to access the sensor mounting bolts. The bolts are either small metric or star bit. Once it's off, the cable is most easily cut from the top.

The crank pulley bolt is 19mm. You will need to stop engine from turning, various methods have been suggested. 1) remove the head, put some rocks into the bore and refit the head. 2) remove a spark plug and put a long bar down the hole 3) remove a plug from cylinder with piston at BTDC and coil in some rope, remove rope when finished.

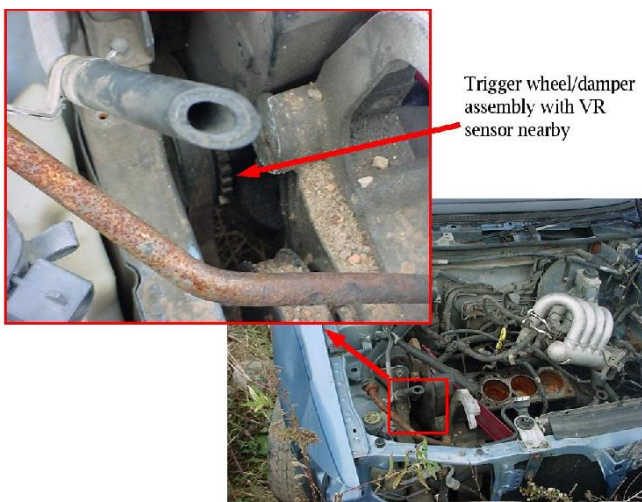
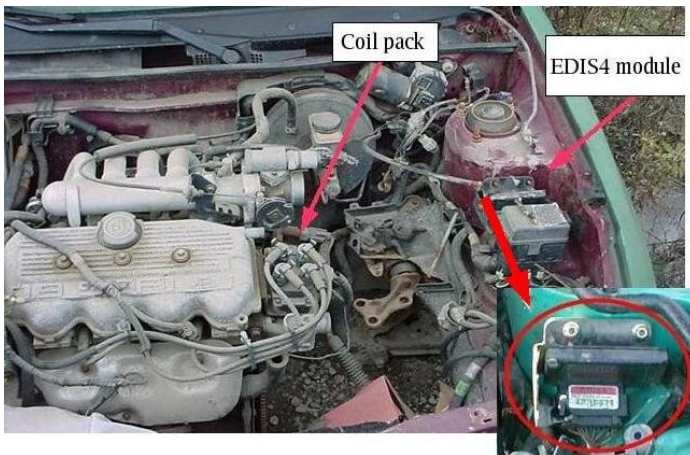

12.2 Europe - EDIS4

1989-1993 Fiesta XR2i 1.6

1990-1992 Fiesta RS turbo

1989-1994 Escort 1.6i

1990-1994 Orion 1.6i

Modules are all in the engine bay and typically located in the middle of the bulkhead or the right hand side as you face the car.

Known part numbers are: 89FB-12K072-AC, 91AB-12K072-AA

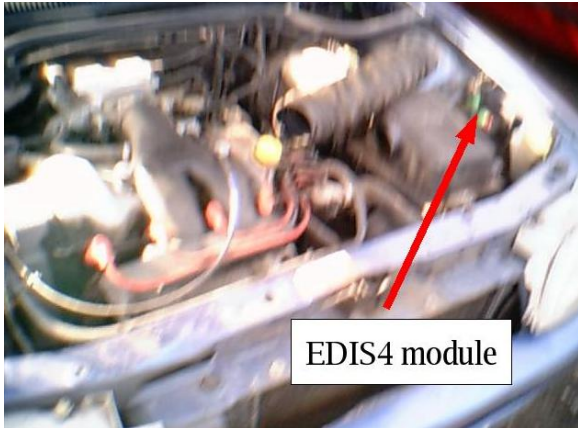

Orion CVH MPI

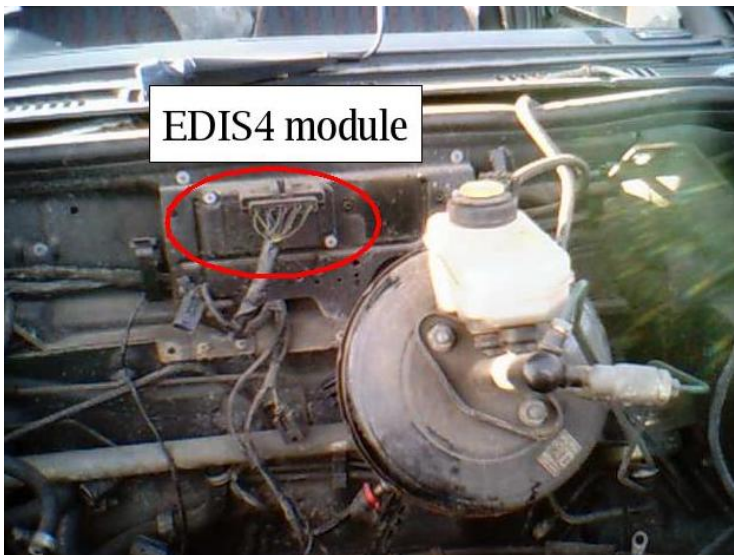

Fiesta / crossflow Escort

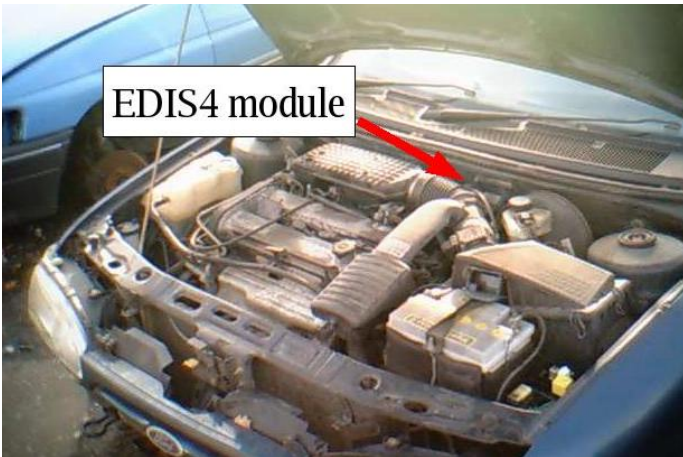

Mondeo with 1800/2000 engine.

Location of the VR sensor varies. On the small CVH engines it pokes through the rear flange of the engine towards the flywheel. 1.8CVH Sierra has one on the front. 2.0DOHC Sierra/ Granada is in the block at the left side way below the inlet manifold. Duratec V6 (Mondeo) is mounted near the front, it also has a cam sensor that works too.

The mounting bolts are either small metric or star bit.

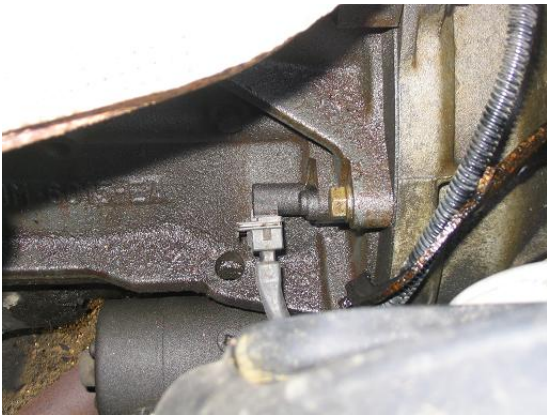

Escort / Fiesta location on engine flange above starter.

Do not confuse with the ESC II hybrid module which has a vacuum tube and comes on the carb model cars.

There is also an aluminium one to avoid as well.



12.3 Europe - EDIS6

up to 1995ish Mondeo V6 automatic

Ford/Cosworth Granada Scorpio 24v V6

Module located rear left of engine bay as you face the car.

Known part numbers are: 90GB-12K072-AB

12.4 Europe - EDIS8

Chances of finding one of these in a scrapyard are very low! Not known to have been installed on any European built vehicles. Your best bet is either to import a module from the USA or buy new. I would suggest buying the other bits locally.

For connectors try one off another car if all the wires are in use or one off an ESC module. The number of wires used in the connector varies so check they are all there!

There is a possibility of using 2 EDIS4 modules to drive a V8. But now that the MS ECU can directly drive 4 coils (V8 in wasted spark) this is no longer necessary.

12.5 Europe - 36-1 trigger disc

The 1.8CVH Sierra has a useful disc pressed onto the back of the crank pulley

All of the other CVH installs have the trigger teeth cut into the flywheel and so are useless.

For a scrap yard trigger disc, remove from 1.8CVH Sierra. You will need to stop engine from turning, various methods have been suggested.

- 1) remove the head, put some old bolts or other junk into the bore and refit the head.
- 2) remove a spark plug and put a long bar down the hole
- 3) remove a plug from cylinder with piston at BTDC and coil in some rope, remove rope when finished
- 4) Jam something into the flywheel teeth



If you are after a pressed steel disc, try part no. 1078767 from Ford, this came on the 16v DOHC Granada engines. Alternatively many retailers sell universal 36-1 trigger wheels.

12.6 Europe - VR sensor



Usually it is easiest to get from the same vehicle as the EDIS module so the wiring harness wiring colors match. Or any vehicle with a trigger disc will yield one, so CVH Fiesta/Escort/Orion or Fiesta with Valencia (crossflow) engine with ESCII hybrid, DOHC Sierra/Granada, Mondeo.

12.7 World - Coilpack(s)

Fords from the EDIS era and beyond use suitable coilpacks.



13: Appendix C: V3.57 Board Setup / Jumpers

13.1 Introduction

The V3.57 mainboard is mostly a factory assembled board. The TO220 devices on the heatsink bar will have been assembled by hand.

As such, there is little required in the way of end-user assembly.

13.2 Build choices

The main items that will need consideration are:

- the tach inputs - see section 5.2
- the ignition outputs - see section 5.3
- jumper wires for stepper idle control - see section 3.5.4.3

13.3 Power transistor mounting

If additional TO220 style power transistors are added, use the following installation diagrams.

TIP125, TIP122, BIP373 require a mica insulator.

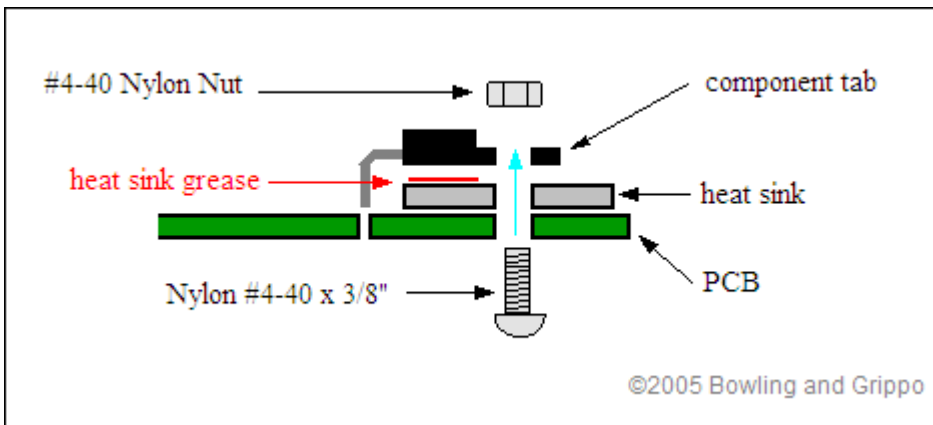

Without mica

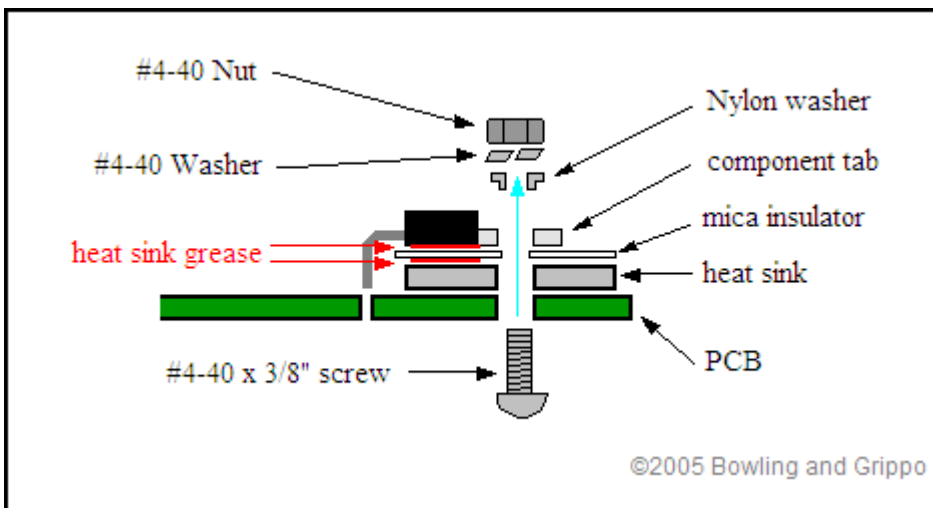

With mica

13.4 Jumper Wires

There are seven recommended jumper wires to install.

S12C to JS9 is required for MS3X and stepper idle operation and should be installed on all ECUs.

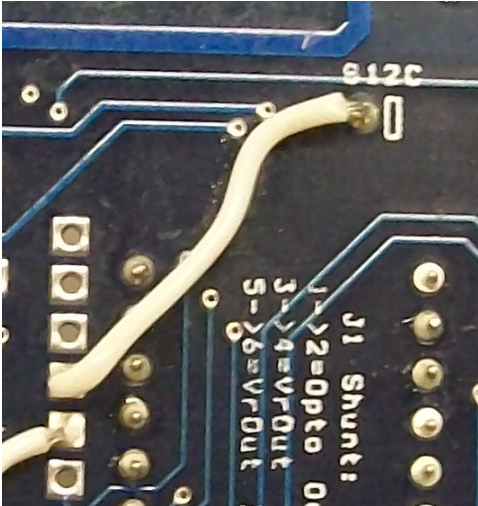

The four orange wires here are stepper:

- a) JS0 to IAC1A
- b) JS1 to IAC1B
- c) JS2 to IAC2A
- d) JS3 to IAC2B

The two white wires are CAN:

- a) JS6 to SPR1 (CANH)
- b) JS8 to SPR2 (CANL)

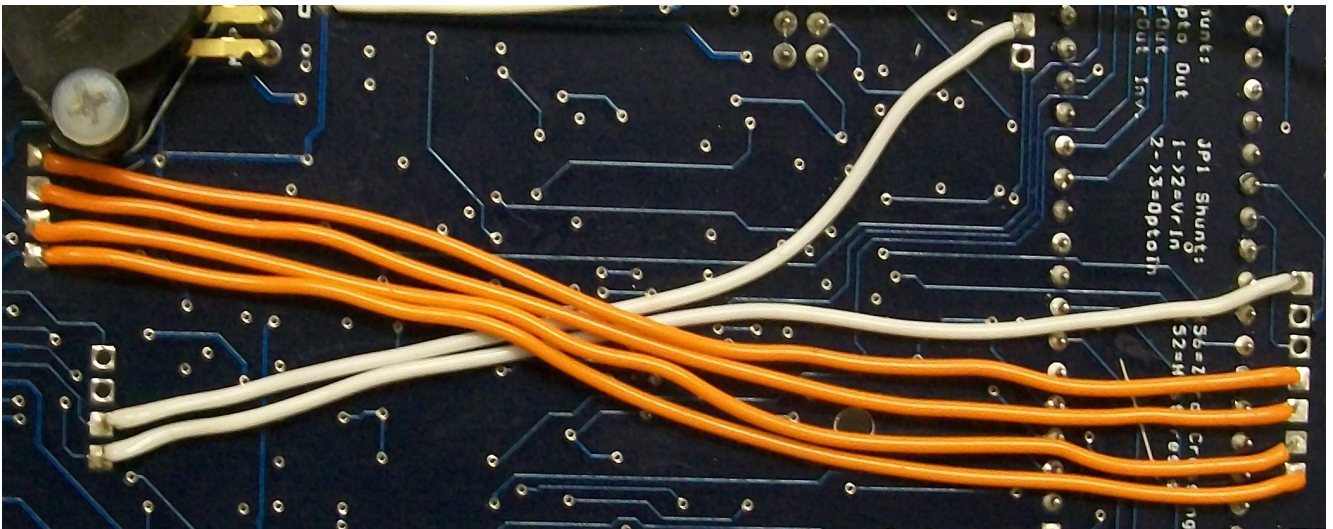

13.5 Voltage Testing

If you require or desire to test for voltages on the board either during setup or for troubleshooting, the following are the voltages that you should see at the CPU socket.

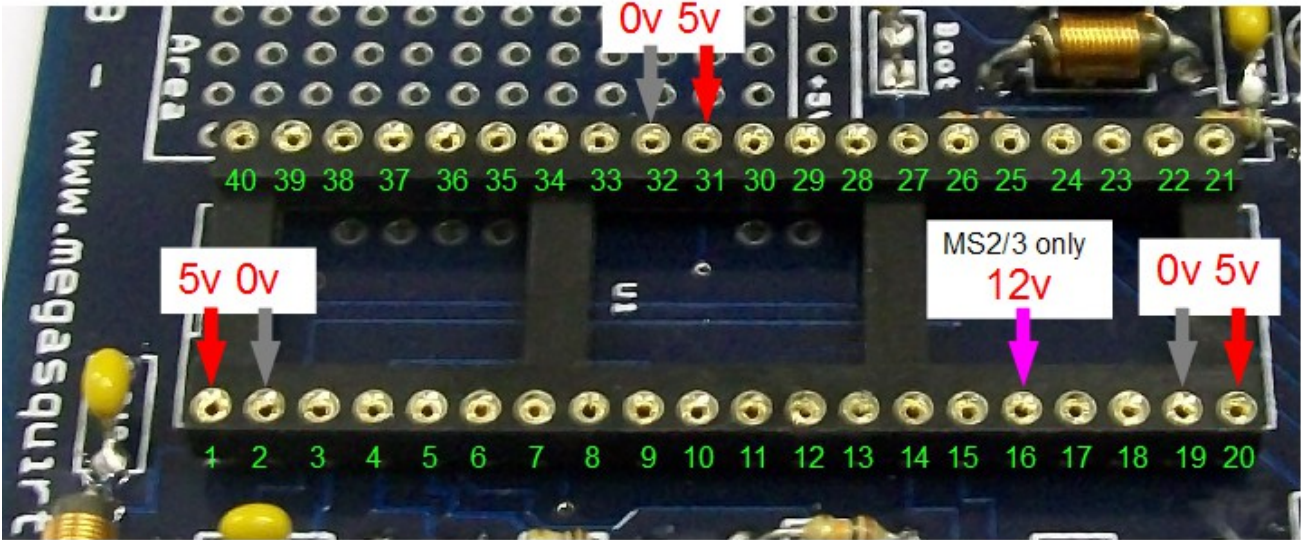

13.6 MS3 CPU Card Mounting

Fit the MS3 CPU card into socket U1.

Note that it is normal for some of the pins on the large square chip on the MS3 card to appear 'bridged'.

- Noting orientation, install the MS3 card onto the mainboard noting the two 40pin socket/spacers that fit between the mainboard and the card. These ensure that the card sits at the right height to align with the end-plate.

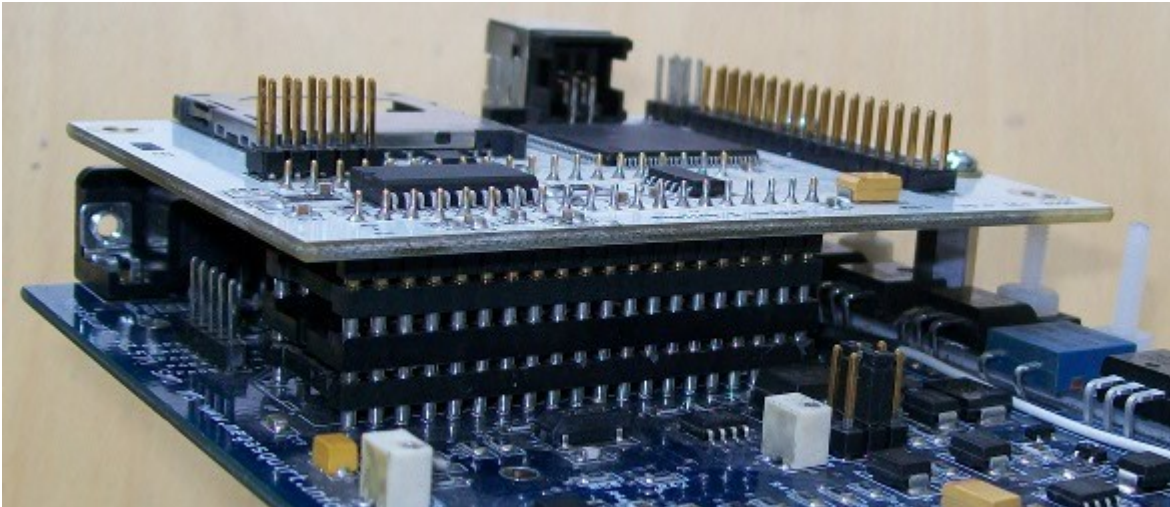

Installing bolts

- If fitted, carefully unscrew and remove the mounting bolt and nuts from U5 and Q11.
- Install the mounting kit on U5 and Q11. The long bolt and a washer install from below. The short bolt and washer from above. Depending on the exact sizes of the components supplied in your kit, you may

- only install one of the standoffs.
- If required, additional washers may be installed between the standoff and the MS3 card to fine-tune the height.

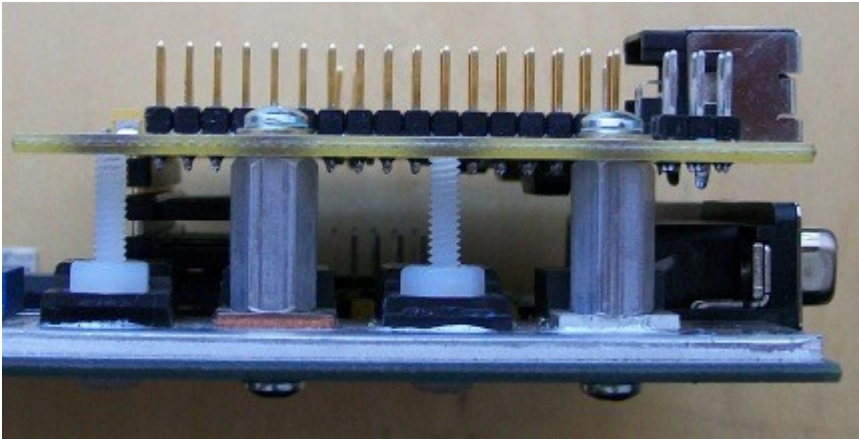

Side view of completed assembly

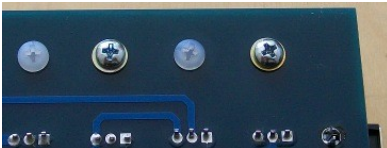

Lower view

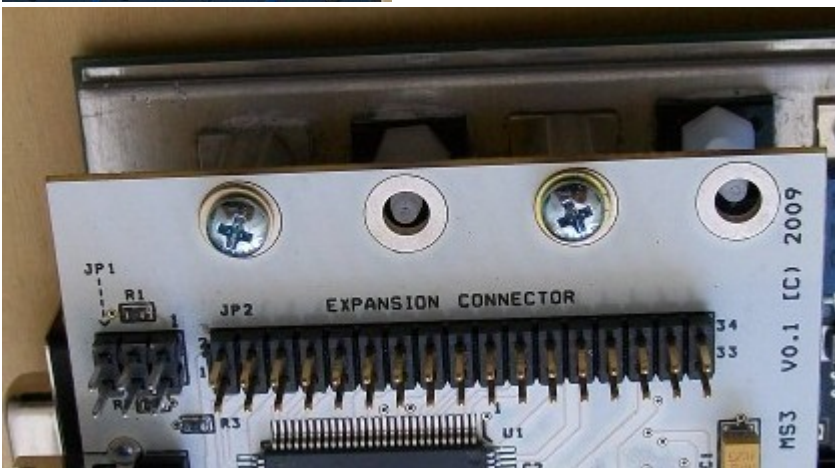

Top view

13.7 Case Fitment

When used with the MS3X, the mainboard, endplate and MS3X assembly needs to be slid into the case as one unit. *For a first start attempt, it makes sense to leave off the case lid in case you need to make a re-adjustment to the VR pots.*

To make it easier to install the end-plate screws, use a 2.5mm drill to open up the hole in the case body. Ensure all swarf is removed.

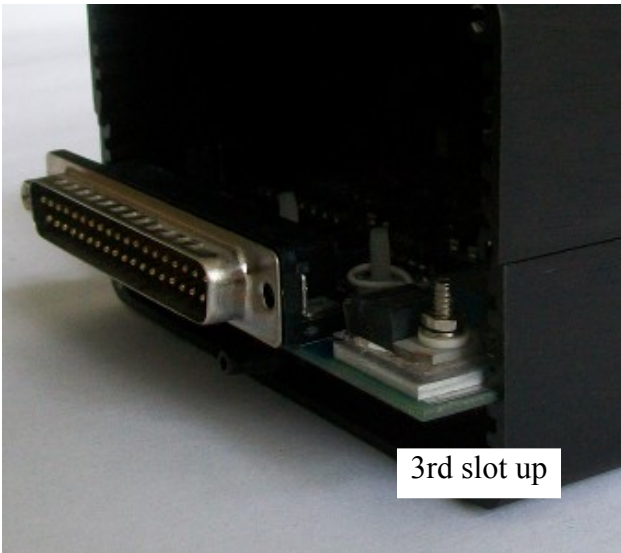

Installing the circuit board into the case in the third slot up.

Having slotted the assembly into the case, screw in the four endplate to case retaining screws. The connector hex bolts may now be tightened up.



The USB end end-plate may now be fitted, screwed onto the case body and the hex bolts fitted.



You are now ready to load the MS3 firmware and follow the other steps in the Quickstart guide contained within the Setting Up Manual.

13.8 Custom circuits

Any custom DIY circuits may need power and ground. On the V3.57 board, you can use the following low current sources.

PAD20 = 12V

PAD4 = GND

PAD5 = 5V

SG = GND

S5 = 5V

High-current ground should be routed back to pin 3 of Q16.

14: Revision history

2014-08-29	First revision. Derived from MS3X/V3.57 Hardware manual.
2014-09-01	Update some case photos.
2014-12-01	Add new CAN wiring diagram. Add 4-wire O2 sensor pic. Update TFI, HEI, 420A, 36-2+2, Miata 99-05, 6G72, 4G63, LS1 input polarities per DIYA.
2014-12-08	Fixed minimal wiring diag.
2015-01-30	Add photos for IAC, CAN, S12C jumper wires. Add photos of tach in 'VR' circuit threshold setting. Relay board section. V357 board diagram.
2015-02-02	Minor edits. Fix EDIS images.
2015-05-05	Correct HEI7/8 output polarity setting. Correct spark output naming. 58X settings.
2015-09-22	Note about ZD for coil neg. Note about returnless fuel.
2015-09-28	TFI notes.
2015-10-12	Add section links for LS.
2016-11-13	Add alternator and EGT sections.
2018-07-06	Remove 1.4.x Ford alternator information. Swap D/P pins on Miata alternator.